

# MAIN GROUP

6

## ROAD WHEELS BRAKES

	Illustration
01 Road wheels	26
05 Mechanical brake	32
09 Hydraulic brake	33
11 Brake cylinders and lines	34
15 Disc brakes	34
98 SP Sets	35

735 116 20

Printed in Germany

11

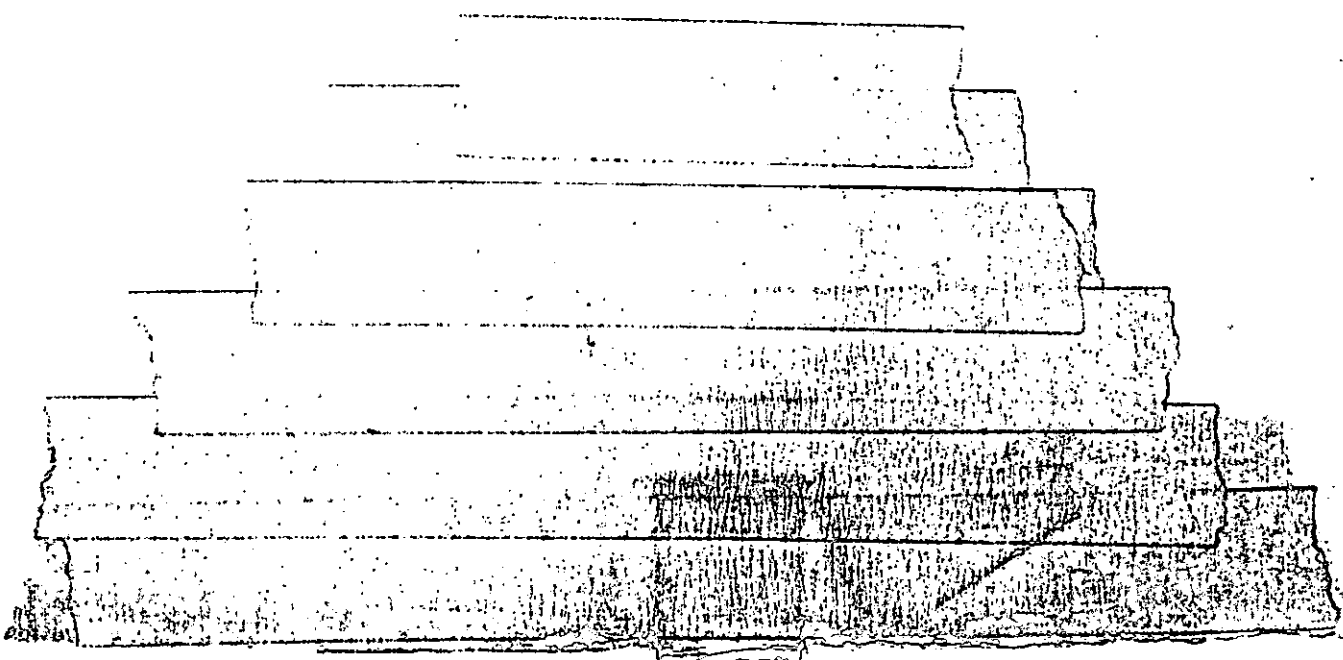

# MAIN GROUP

6

## ROAD WHEELS BRAKES

	Illustration
01 Road wheels	31
05 Mechanical brake	32
09 Back plate, brake shoes with linings, front	33
09 Back plate, brake shoes with linings, rear	A 33
11 Brake master cylinder	34
11 Wheel brake cylinder	A 34
11 Reservoir with lines to brake master cylinder	B 34
11 Front brake circuit lines	C 34
11 Rear brake circuit lines	D 34
15 Disc brakes	35
98 Repair kits	—

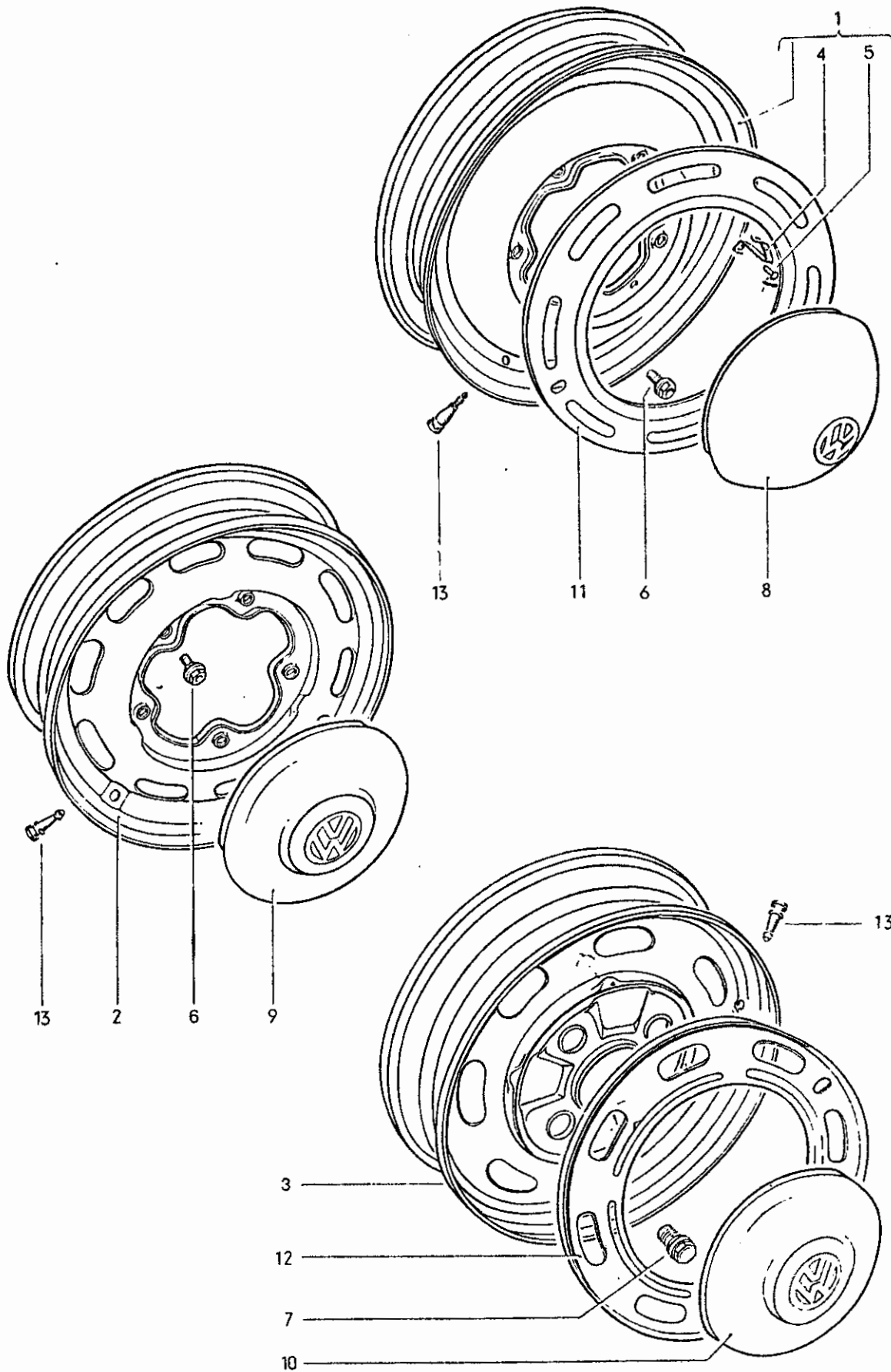

Key No.	Part No.	Description	Quantity	Type and model
<b>ROAD WHEELS</b>				111-118, 141-144, 151, 152
-	111 601 021	Wheel disc 3.00×D-16 (5 hole mounting) ..... up to Chassis No. 1 - 397 022	5	111-118, 151, 152
1	111 601 025 C	Wheel disc 4 J×15 (5 hole mounting) ..... from Chassis No. 1 - 397 023 up to 115 999 000	5	
2	111 601 025 E *	Wheel disc 4 J×15 (5 hole mounting) ..... from Chassis No. 116 000 001 up to 116 1021 300 from Chassis No. 117 000 001 up to 117 999 000	5 5	111, 112, 115, 116; M 87, M 88, M 129, M 137, M 139
3	111 601 025 F <i>Sdy</i> <i>111 601 025 F</i>	Wheel disc 4 1/2 J×15 (4 hole mounting) ..... from Chassis No. January 1972	5	111-118, 151, 152
(3)	141 601 025	Wheel disc 4 J×15 (4 hole mounting) ..... from Chassis No. 117 000 001 up to 117 999 000  from Chassis No. 148 000 001 up to 148 469 573 from Chassis 118 000 001 up to December 1971	5 5 5	113, 114, 117, 118, 141-144, 151, 152 141-144 111-118, 151, 152
-	311 601 025 C	Wheel disc 4.5 J×15 (4 hole mounting) ..... from Chassis No. 148 469 574	5	141-144
-	N 20 102 1	Screw-type valve - Tubeless tires .....	5	111-118, 151, 152
4	111 601 131	Spring - Hub cap ..... up to Chassis No. 115 999 000	25	
5	N 13 407 1	Rivet, button head 4.5×7 ..... up to Chassis No. 115 999 000	25	
6	111 601 139 *	Bolt M 12×1.5 - Wheel disc ..... up to Chassis No. 116 1021 300 from Chassis No. 117 000 001 up to 117 999 000	20 20	111, 112, 115, 116; M 87, M 88, M 129, M 137, M 139
7	211 601 139 <i>USA</i>	Bolt M 14×1.5 - Wheel disc ..... from Chassis No. 117 000 001 up to 117 999 000  from Chassis No. 118 000 001	16 16	113, 114, 117, 118, 141-144, 151, 152
-	111 601 141 *	Bolt M 14×1.5 (oversize) - Wheel disc ..... up to Chassis No. 116 1021 300 from Chassis No. 117 000 001 up to 117 999 000	x x	111, 112, 115, 116; M 87, M 88, M 129, M 137, M 139



Key No.	Part No.	Description	Quantity	Type and model
-	111 601 151	Hub cap (5 hole mounting) ..... up to Chassis No. 115 999 000	4	111, 112, 115, 116
-	111 601 151 C	Hub cap (5 hole mounting) ..... from Chassis No. 116 000 001 up to 116 1021 300	4	111, 112, 115, 116
		from Chassis No. 117 000 001 up to 117 999 000	4	111, 112, 115, 116; M 129, M 139
-	111 601 151 E	Hub cap (4 hole mounting) ..... from Chassis No. 118 000 001	4	M 149
8	113 601 151	Hub cap (chromium plated) (5 hole mounting) ... up to Chassis No. 115 999 000	4	113, 114, 117, 118, 141-144, 151, 152
9	131 601 151	* Hub cap (chromium plated) (5 hole mounting) ... from Chassis No. 116 000 001 up to 116 1021 300	4	113, 114, 117, 118, 141-144, 151, 152; M 1
		from Chassis No. 117 000 001 up to 117 999 000	4	M 1, M 86, M 87, M 88, M 137
10	311 601 151 D	Hub cap (chromium plated) (4 hole mounting) ... from Chassis No. 117 000 001 up to 117 999 000	4	113, 114, 117, 118, 141-144, 151, 152
		from Chassis No. 118 000 001	4	
11	141 601 155	Rim embellisher - Road wheel (5 hole mounting) from Chassis No. 6 081 462 up to 145 999 000	4	141-144, 151, 152
-	141 601 155 B	* Rim embellisher - Road wheel (5 hole mounting) from Chassis No. 146 000 001 up to 146 1021 300	4	141-144, 151, 152
		from Chassis No. 117 000 001 up to 117 999 000	4	M 218/M 87; M 218/ M 88; M 218/M 137
12	311 601 155	Rim embellisher - Road wheel (4 hole mounting) from Chassis No. 147 000 001 up to 147 999 000	4	141-144, 151, 152; M 218: 113, 114, 117, 118
		from Chassis No. 148 000 001 up to 149 1200 000	4	141-144, 151, 152; M 218
-	111 601 161	Ferrule - Hub cap ..... up to Chassis No. 115 999 000	16	
-	141 601 180	Spring for balance weight .....	x	
-	311 601 181	Balance weight 20 g .....	x	

Key No.	Part No.	Description	Quantity	Type and model
-	311 601 182	Balance weight 30 g .....	x	
-	311 601 183	Balance weight 40 g .....	x	
-	311 601 185 A	Balance weight 60 g .....	x	
-	311 601 187 A	Balance weight 80 g .....	x	
-	311 601 189 A	Balance weight 100 g .....	x	
13	111 601 361	Rubber valve – Tubeless tires up to Chassis No. 118 1016 100	5	
-	311 601 361	Rubber valve – Tubeless tires from Chassis No. 119 000 001	5	

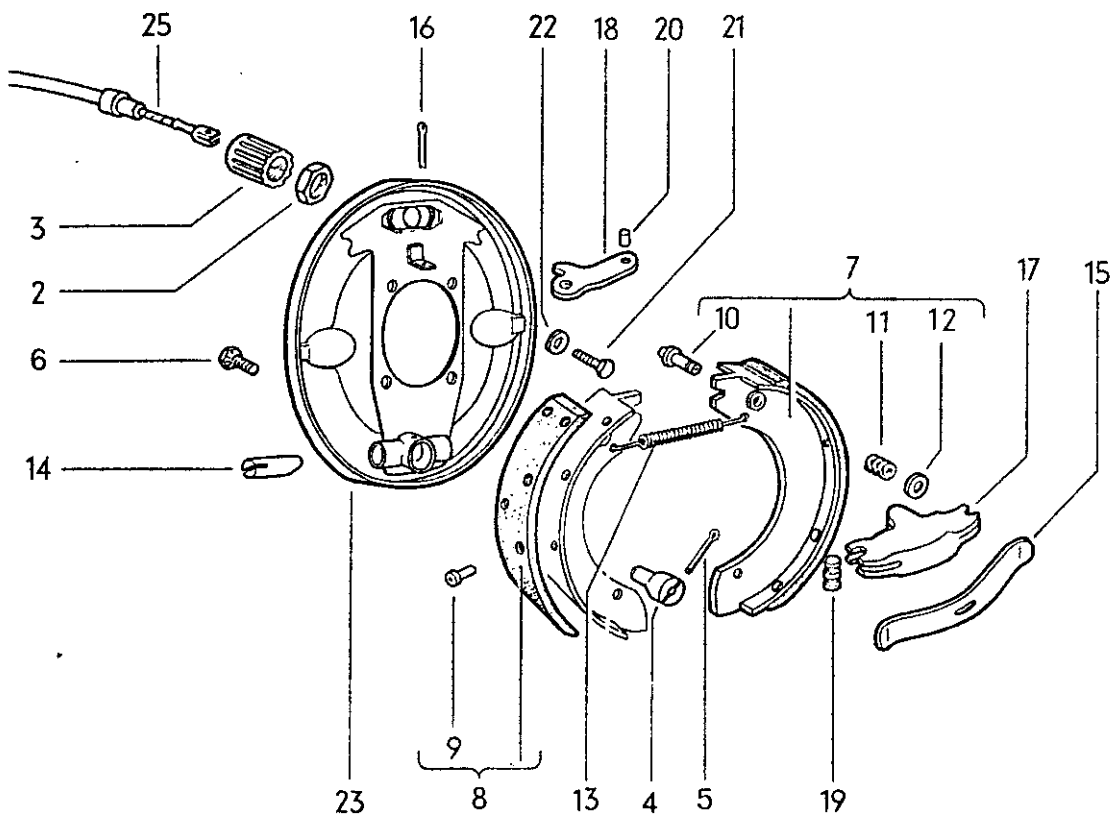
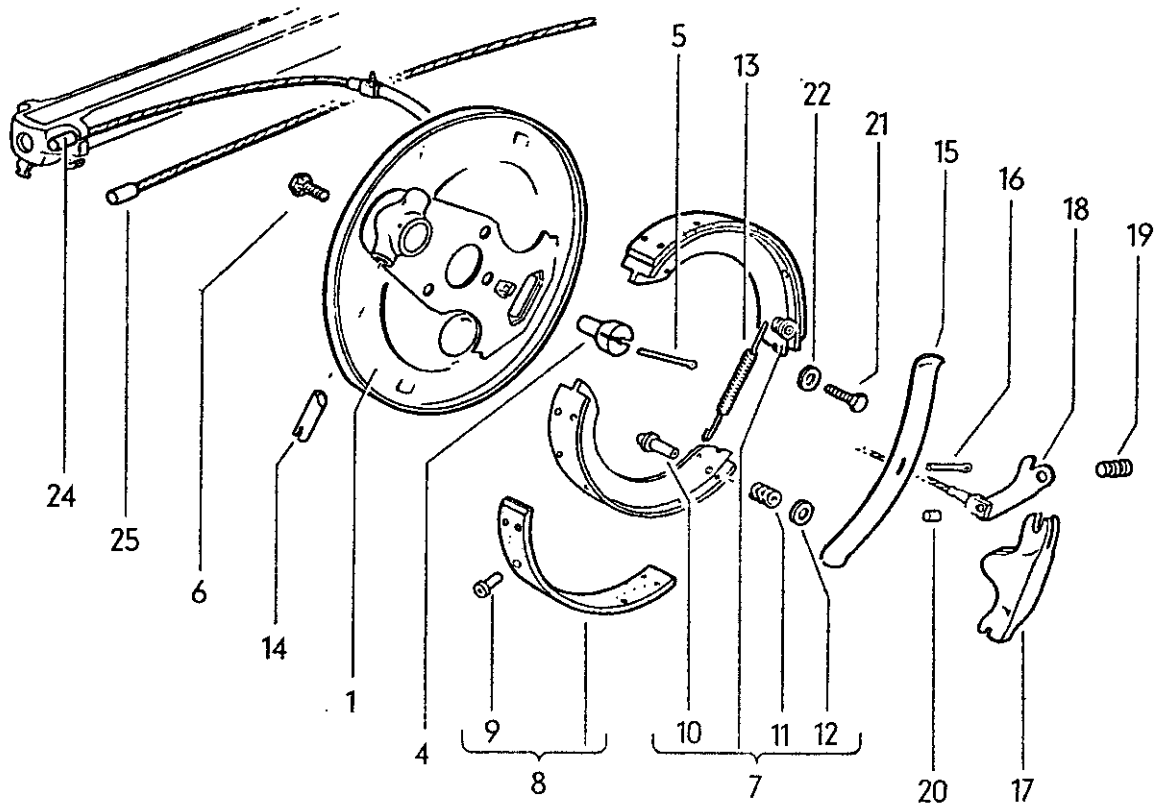



Key No.	Part No.	Description	Quantity	Type and model
<b>MECHANICAL BRAKE</b>				
up to Chassis No. 4 630 937				111, 112, 115, 116
1	111 605 139	Back plate – Front brake, left .....	1	
-	111 605 140	Back plate – Front brake, right .....	1	
2	111 605 187	Lock nut – Brake cable adjusting sleeve .....	4	
3	111 605 191	Adjusting sleeve – Brake cable .....	4	
4	111 605 195	Cone – Brake shoe adjuster .....	4	
5	N 12 540 1	Cotter pin 3×40 .....	4	
6	111 605 199	Screw – Brake shoe adjuster cone .....	4	
7	111 605 237 A	Brake shoe 30 and lining .....	4	
-	111 605 238 A	Brake shoe 30 and lining .....	4	
8	111 698 051	1 set of brake linings 30 (Jurid) .....	x	
-	111 698 054	1 set of brake linings 30 (Energit) 0.5 mm oversize	x	
9	*N 13 634 1	Rivet C 4×7.5 .....	64	
10	111 605 277	Retainer bolt – Brake shoe .....	8	
11	111 605 283	Pressure spring – Brake shoe .....	8	
12	111 605 289 A	Washer – Pressure spring .....	8	
13	111 605 301	Return spring – Brake shoe .....	8	
14	111 605 321	Locating pin – Brake shoe .....	8	
15	111 605 325	Leaf spring – Brake shoe .....	4	
16	N 12 530 1	Cotter pin 3×15 .....	4	



Key No.	Part No.	Description	Quantity	Type and model
17	111 605 331	Expander – Brake shoe .....	4	
18	111 605 335 A	Brake shoe lever .....	4	
19	111 605 341	Pin – Expander and operating lever .....	4	
20	111 605 347	Pin – Brake cable .....	4	
21	113 609 385	Bolt, hex. head M 10×22 .....	6	
		Back plate mounting front (replace all screws and N 12 011 1 up to Chassis No. 2 855 921)		
22	N 12 011 1	Lock washer A 10 .....	6	
23	111 605 439	Back plate – Rear brake .....	2	
24	111 605 701	Cable – Front brake (length 892 mm) .....	2	
25	111 605 721	Cable – Rear brake (length 2946 mm) .....	2	
–	111 605 737	Distance piece – Brake cable (front and rear) ....	x	



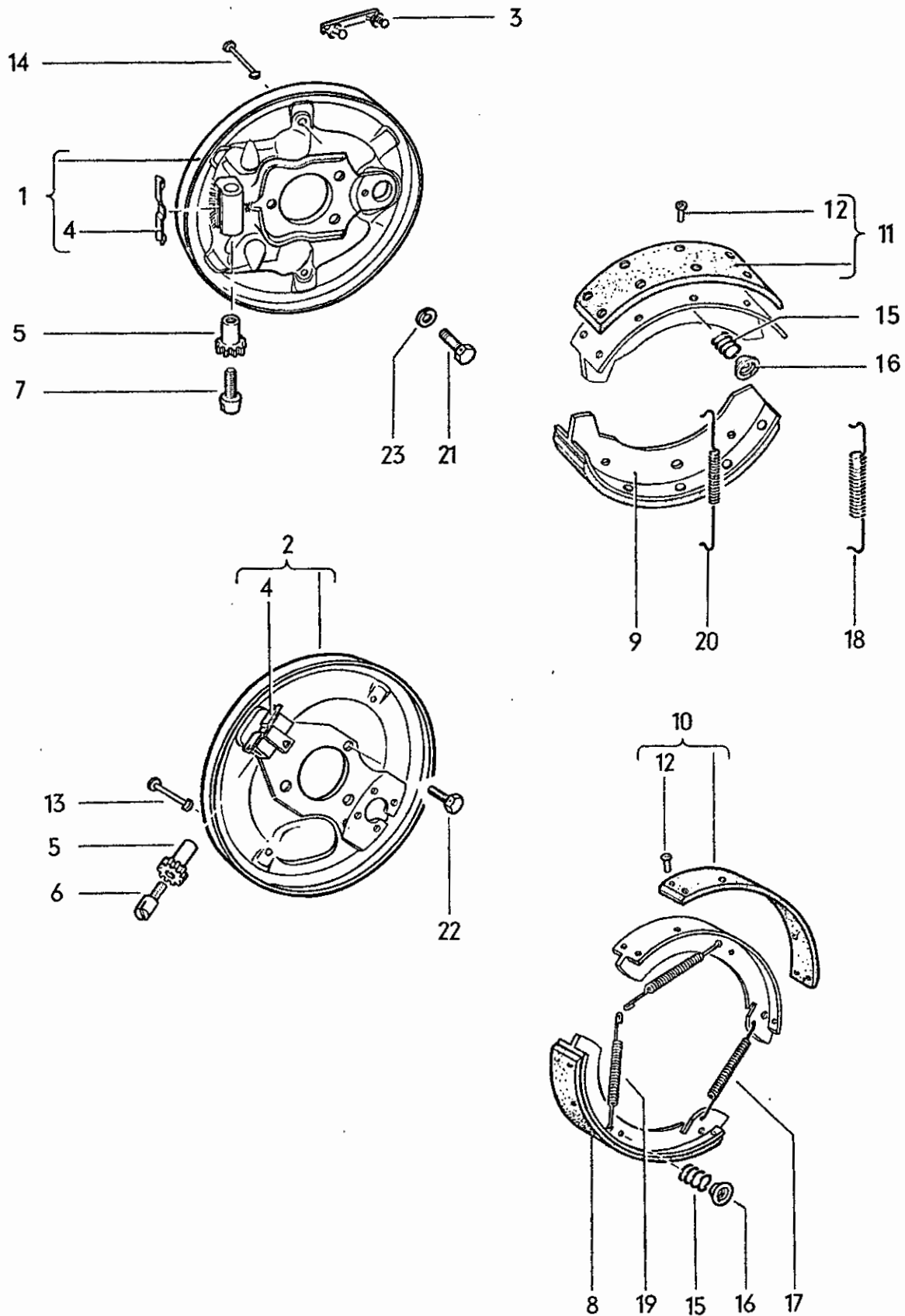

Key No.	Part No.	Description	Quantity	Type and model
<b>BACK PLATE, BRAKE SHOES WITH LININGS, FRONT</b>				
		up to Chassis No. 4 630 937		113, 114, 117, 118, 141-144, 151, 152
		from Chassis No. 4 630 938 up to 116 1021 300		111-118, 141-144, 151, 152
		from Chassis No. 117 000 001		111, 112, 115, 116; M 87, M 88, M 129, M 137, M 139
		from Chassis No. 111 2000 001		M 1/M 87, M 1/M 88, M 1/M 108, M 1/M 110, M 137
1	113 609 125 G	* Back plate – Front brake from Chassis No. 111 2000 001	2	M 87, M 88, M 137
(2)	113 609 139	Back plate – Front brake, left up to Chassis No. 1 673 410	1	
(2)	113 609 139 A	Back plate – Front brake from Chassis No. 1 673 411 up to 6 502 399	2	
(2)	113 609 139 B	Back plate – Front brake from Chassis No. 115 000 001 up to 115 999 000	2	
2	181 609 139	Back plate – Front brake from Chassis No. 116 000 001 up to 110 3100 000 from Chassis No. 111 2000 001 (use 2 × 481 609 163 up to Chassis No. 117 999 000)	2 2	111, 112, 115, 116; M 1/M 87, M 1/M 88, M 1/M 108, M 1/M 110
(2)	113 609 140	Back plate – Front brake, right up to Chassis No. 1 673 410	1	
3	481 609 163	Sealing bridge – Back plate from Chassis No. 118 000 001	4	
(4)	211 609 185	Leaf spring – Adjusting device (screwed) up to Chassis No. 1 – 575 414	2	
-	N 11 225 1	Screw, buffon head AM 3×4 up to Chassis No. 1 – 575 414	4	
-	N 12 003 1	Lock washer B 3 up to Chassis No. 1 – 575 414	4	
4	211 609 185 A	Leaf spring – Adjusting device (peened)	2	
(4)	311 609 485	* Leaf spring – Adjusting device from Chassis No. 111 2000 001	2	M 87, M 88, M 137

Key No.	Part No.	Description	Quantity	Type and model
5	113 609 205 A	Adjusting nut – Brake shoe .....	4	
(6)	211 609 209	Adjusting screw – .....	4	
		Brake shoe 113 609 237/C/D up to Chassis No. 6 502 399		
6	113 609 209	Adjusting screw – Brake shoe 113 609 237 A .....	4	
		up to Chassis No. 1 673 410		
7	131 609 209	Adjusting screw – Brake shoe 131 609 377/C .....	4	
		from Chassis No. 115 000 001		
(7)	311 609 209 A *	Adjusting screw – Brake shoe .....	4	M 87; M 88; M 137
		from Chassis No. 111 2000 001		
–	113 609 211	Spacer .....	2	
		up to Chassis No. 1 – 575 414		
–	113 609 213	Washer (to eliminate knocking) .....	x	
		up to Chassis No. 1 – 575 414		
(8)	113 609 237	Brake shoe 30 and lining .....	4	
		up to Chassis No. 1 – 575 414		
8	113 609 237 A	Brake shoe 30 and lining .....	4	
		from Chassis No. 1 – 575 415 up to 1 673 410		
(9)	113 609 237 D	Brake shoe 40 and lining .....	4	
		from Chassis No. 1 673 411 up to 6 502 399		
9	131 609 237 C	Brake shoe 40 and lining .....	4	
		from Chassis No. 115 000 001		
(9)	113 609 237 H	Brake shoe 45 and lining .....	4	M 87, M 88, M 137:
		from Chassis No. 111 2000 001		113, 114, 117, 118, 151, 152
		use: 113 609 605 C (see Workshop Bulletin B 29)		
10	111 698 051	1 set of brake linings 30 .....	1	
		up to Chassis No. 1 673 410		
(10)	111 698 054	1 set of brake linings 30 (0.5 mm oversize) .....	x	
		up to Chassis No. 1 673 410		
(11)	111 698 074	1 set of brake linings 40 (0.5 mm oversize) .....	x	
		from Chassis No. 1 673 411		

Key No.	Part No.	Description	Quantity	Type and model
11	111 698 075	1 set of brake linings 40 ..... from Chassis No. 1 673 411	1	
12	*N 13 634 1	Rivet C 4X7.5 .....	36	
13	113 609 279 C	Retaining pin 25 mm – Brake shoe ..... up to Chassis No. 6 502 399	4	
(14)	211 609 279	* Retaining pin 40 mm – Brake shoe ..... from Chassis No. 111 2000 001	4	M 87; M 88; M 137
14	311 609 579	Retaining pin 37 mm – Brake shoe ..... from Chassis No. 115 000 001	4	
15	113 609 283	Spring – Retaining pin .....	4	
16	113 609 289	Spring seat – Retaining pin .....	4	
17	113 609 301	Return spring (lower) – Brake shoe ..... up to Chassis No. 1 673 410	2	
18	113 609 301 B	Return spring, rear – Brake shoe ..... from Chassis No. 1 673 411	2	
(19)	113 609 605 C	Return spring, rear – Brake shoe ..... from Chassis No. July 1971 use: 113 609 237 H (see Workshop Bulletin B 29)	2	M 87, M 88, M 197; 113, 114, 117, 118, 151, 152
(19)	311 609 605	* Return spring (upper) – Brake shoe, front ..... from Chassis No. 111 2000 001 up to June 1971	2	M 87; M 88; M 137
19	113 609 309	Return spring (upper) – Brake shoe ..... up to Chassis No. 1 673 410	4	
20	113 609 309 B	Return spring, front – Brake shoe ..... from Chassis No. 1 673 411	2	
(19)	311 609 609	* Return spring (lower) – Brake shoe, front ..... from Chassis No. 111 2000 001	4	M 87; M 88; M 137
(19)	211 609 313	Return spring (upper) – Brake shoe ..... up to Chassis No. 1 673 410	2	
21	113 609 381	Bolt, hex. head M 10X18 – ..... Back plat emouting front from Chassis No. 2 855 922	6	
22	113 609 385	Bolt, hex. head M 10X22 – ..... Back plate mounting front replace all screws and N 12 011 2 up to Chassis No. 2 855 921	6	
23	N 12 011 2	Lock washer A 10 .....	6	

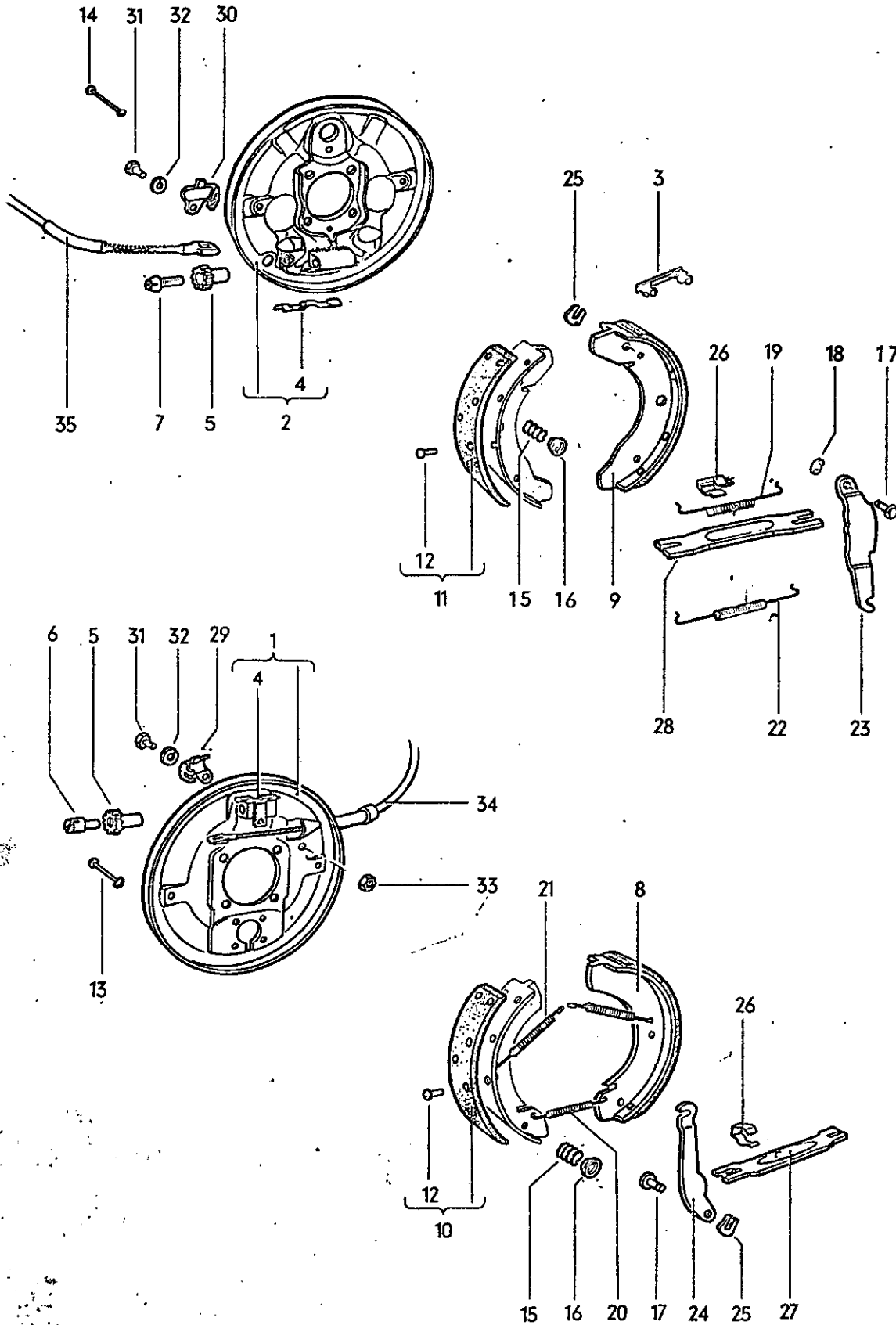



Key No.	Part No.	Description	Quantity	Type and model
<b>BACK PLATE, BRAKE SHOES WITH LININGS, REAR</b>				
		up to Chassis No. 4 630 937		113, 114, 117, 118, 141-144, 151, 152
		from Chassis No. 4 630 938		111-118, 141-144, 151, 152
		from Chassis No. 111 2000 001		M 1
1	113 609 439	Back plate – Rear brake, left ..... up to Chassis No. 1 673 410	1	
(1)	113 609 439 B	Back plate – Rear brake, left ..... from Chassis No. 1 673 411 up to 6 502 399	1	
(1)	113 609 439 C	Back plate – Rear brake, left ..... (up to Chassis No. 116 1021 300, 481 609 163 is additionally required) from Chassis No. 115 000 001 up to 117 999 000 from Chassis No. 118 000 001 up to 118 328 505	1 1 1	111, 112, 115, 116; M 88
2	113 609 439 E	Back plate – Rear brake, left ..... from Chassis No. 118 000 001 up to 118 328 505  from Chassis No. 118 328 506	1 1	113, 114, 117, 118, 141-144, 151, 152; M 87
(1)	113 609 440	Back plate – Rear brake, right ..... up to Chassis No. 1 673 410	1	
(1)	113 609 440 B	Back plate – Rear brake, right ..... from Chassis No. 1 673 411 up to 6 502 399	1	
(1)	113 609 440 C	Back plate – Rear brake, right ..... (up to Chassis No. 116 1021 300, 481 609 163 is additionally required) from Chassis No. 115 000 001 up to 117 999 000 from Chassis No. 118 000 001 up to 118 328 505	1 1 1	111, 112, 115, 116; M 88
(2)	113 609 440 E	Back plate – Rear brake, right ..... from Chassis No. 118 000 001 up to 118 328 505  from Chassis No. 118 328 506	1 1	113, 114, 117, 118, 141-144, 151, 152; M 87
3	481 609 163	Sealing bridge – Back plate ..... from Chassis No. 117 000 001 up to 118 328 505  from Chassis No. 118 328 506	4 4	113, 114, 117, 118, 141-144, 151, 152
(4)	211 609 185	Leaf spring – Adjusting device (screwed) ..... up to Chassis No. 1 – 575 414	2	
-	N 11 225 1	Screw, button head AM 3×4 ..... up to Chassis No. 1 – 575 414	4	

Key No.	Part No.	Description	Quantity	Type and model
-	N 12 003 1	Lock washer B 3 ..... up to Chassis No. 1 - 575 414	4	
4	211 609 185 A	Leaf spring - Adjusting device (peened) .....	2	
5	113 609 205 A	Adjusting nut - Brake shoe .....	4	
(6)	211 609 209	Adjusting nut - Brake shoe 113 609 237/537 A/B .. up to Chassis No. 6 502 399	4	
6	113 609 209	Adjusting nut - Brake shoe 113 609 237 A .....	4	
		from Chassis No. 1 - 575 415 up to 1 673 410		
7	131 609 209	Adjusting nut - Brake shoe .....	4	
		from Chassis No. 115 000 001		
-	113 609 211	Spacer .....	2	
		up to Chassis No. 1 - 575 414		
-	113 609 213	Washer (to eliminate brake knocking) .....	x	
		up to Chassis No. 1 - 575 414		
(8)	113 609 237	Brake shoe 30, with lining .....	4	
		up to Chassis No. 1 - 575 414		
(8)	113 609 237 A	Brake shoe 30, with lining .....	4	
		from Chassis No. 1 - 575 415 up to 1 673 410		
8	113 609 537 B	Brake shoe 30, with lining .....	4	
		from Chassis No. 1 673 411 up to 6 502 399		
9	113 609 537 C	Brake shoe 40, with lining .....	4	113, 114, 117, 118,
		from Chassis No. 118 000 001 up to 118 328 505	4	141-144, 151, 152; M 87
		from Chassis No. 118 328 506	4	
(8)	131 609 537 C	Brake shoe 30, with lining .....	4	
		from Chassis No. 115 000 001 up to 117 999 000	4	
		from Chassis No. 118 000 001 up to 118 328 505	4	111, 112, 115, 116; M 88

Key No.	Part No.	Description	Quantity	Type and model
10	111 698 051	1 set of brake linings 30 ..... up to Chassis No. 117 999 000 from Chassis No. 118 000 001 up to 118 328 505	1 1	111, 112, 115, 116; M 88
(10)	111 698 054	1 set of brake linings 30 ..... 0.5 mm oversize up to Chassis No. 117 999 000 from Chassis No. 118 000 001 up to 118 328 505	x x	111, 112, 115, 116; M 88
(11)	111 698 074	1 set of brake linings 40 ..... 0.5 mm oversize from Chassis No. 118 000 001 up to 118 328 505  from Chassis No. 118 328 506	x  x	113, 114, 117, 118, 141-144, 151, 152; M 87
11	111 698 075	1 set of brake linings 40 ..... from Chassis No. 118 000 001 up to 118 328 505  from Chassis No. 118 328 506	1  1	113, 114, 117, 118, 141-144, 151, 152; M 87
12	*N 13 634 1	Rivet C 4x7.5 .....	36	
13	113 609 279 A	Retaining pin 30 mm - Brake shoe 113 609 537 A/B up to Chassis No. 6 502 399	4	
14	311 609 579	Retaining pin 37 mm - Brake shoe ..... from Chassis No. 118 000 001 up to 118 328 505 from Chassis No. 118 328 506	4 4	113, 114, 117, 118, 141-144, 151, 152; M 87
(14)	113 609 279 C	Retaining pin 25 mm - Brake shoe ..... up to Chassis No. 117 999 000 from Chassis No. 118 000 001 up to 118 328 505	4 4	111, 112, 115, 116; M 88
15	113 609 283	Spring - Retaining pin .....	4	
16	113 609 289	Spring seat - Retaining pin .....	4	
17	211 609 601 A	Anchor pin - Brake lever .....	2	
18	N 12 228 2	Spring washer B 8 .....	2	
19	113 609 605 A	Return spring (upper) - Brake shoe ..... from Chassis No. 1 673 411	2	
20	113 609 301	Return spring (lower) - Brake shoe ..... up to Chassis No. 1 673 410	2	

Key No.	Part No.	Description	Quantity	Type and model
21	113 609 309	Return spring (upper) – Brake shoe ..... from Chassis No. 1 – 575 415 up to 1 673 410	4	
(21)	211 609 313	Return spring (upper) – Brake shoe ..... up to Chassis No. 1 – 575 414	2	
22	113 609 309 B	Return spring (lower) – Brake shoe ..... from Chassis No. 1 673 411	2	
(23)	211 609 613	Brake lever – Brake shoe ..... up to Chassis No. 1 673 410	1	
23	113 609 613 A	Brake lever, left – Brake shoe ..... from Chassis No. 1 673 411	1	
24	211 609 614	Brake lever – Brake shoe ..... up to Chassis No. 1 673 410	1	
(23)	113 609 614 A	Brake lever, right – Brake shoe ..... from Chassis No. 1 673 411	1	
25	211 609 619	C-Washer – Brake lever anchor pin ..... .....	2	
26	113 609 625	Spring clip – Push bar ..... .....	2	
27	211 609 631	Push bar – Brake shoe ..... up to Chassis No. 1 673 410	1	
28	311 609 631	Push bar – Brake shoe ..... from Chassis No. 1 673 411	2	
(27)	211 609 632	Push bar – Brake shoe ..... up to Chassis No. 1 673 410	1	
29	113 609 637	Bracket – Brake cable ..... up to Chassis No. 1 673 410 left from Chassis No. 1 673 411 right	1	
30	113 609 638	Bracket – Brake cable ..... up to Chassis No. 1 673 410 right from Chassis No. 1 673 411 left	1	
31	N 10 238 4	Bolt, hex. head M 8×15 ..... .....	2	
32	N 12 008 2	Lock washer B 8 ..... .....	2	

Key No.	Part No.	Description	Quantity	Type and model
33	N 11 008 B	Nut, hex. M 8 ..... up to Chassis No. 1 673 410	2	113, 114, 117, 118, 151, 152
(34)	113 609 721	Cable - Rear brake (3031 mm - 119 11/32 in.) .... up to Chassis No. 1 - 929 745 (if fitted with lever type shock absorbers)	2	113, 114, 117, 118, 151, 152
(34)	113 609 721 A	Cable - Rear brake (3131 mm - 123 9/32 in.) ..... up to Chassis No. 1 - 929 745 (if fitted with telescopic shock absorbers)	2	113, 114, 117, 118, 151, 152
34	113 609 721 B	Cable - Rear brake (1920 mm - 75 19/32 in.) ..... from Chassis No. 1 - 929 746 up to 1 600 439	2	113, 114, 117, 118, 143, 151, 152
(35)	113 609 721 F	Cable - Rear brake (1750 mm - 68 29/32 in.) ..... from Chassis No. 1 600 440 up to 1 15 400 108	2	
(35)	113 609 721 J	* Brake cable, rear (1810 mm - 71 1/4 in.) ..... up to Chassis No. 110-21200 000 from Chassis No. 111 2000 001	2 2 2	M 4: 141-144; M 9 M 4 113, 114, 117, 118, 151, 152; M 1/M 4
(35)	113 609 721 L	Cable - Rear brake (1775 mm - 69 7/8 in.) ..... from Chassis No. 115 400 109 up to 117 999 000	2	
35	113 609 721 M	Cable - Rear brake (1722 mm - 67 25/32 in.) ..... from Chassis No. 118 000 001 up to 110 21200 000 from Chassis No. 111 2000 001	2 2	111, 112, 115, 116, 141-144; M 1

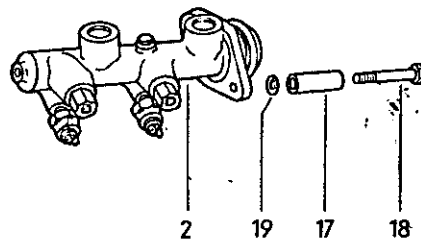
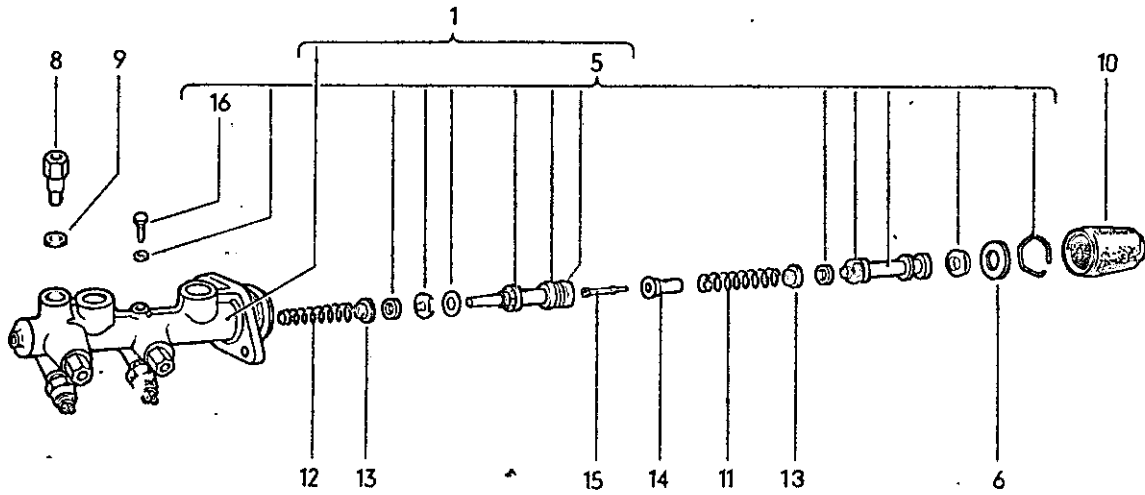
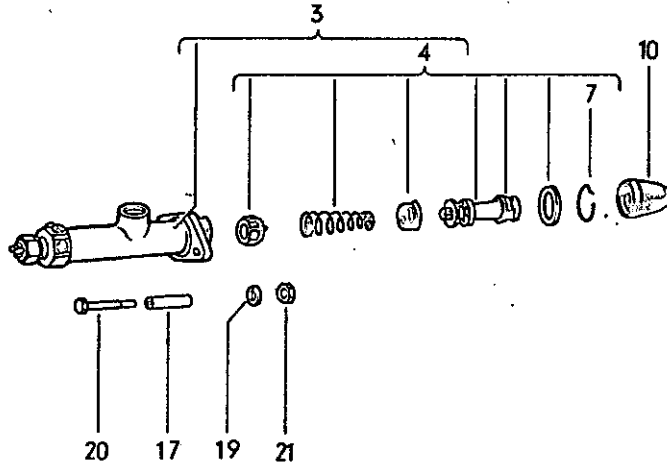

Key No.	Part No.	Description	Quantity	Type and model
<b>BRAKE CYLINDERS AND LINES</b>				
		Single circuit drum brakes up to Chassis No. 4 630 937		113, 114, 117, 118, 141-144, 151, 152
		from Chassis No. 4 630 938 up to 116 1021 300		111-118, 141-144, 151, 152
		from Chassis No. 117 000 001 up to 117 999 000		111, 112, 115, 116; M 87, M 88
		from Chassis No. 118 000 001 up to 119 1200 000		111, 112, 115, 116
		Dual circuit drum brakes from Chassis No. 117 000 001 up to 117 999 000		M 137, M 139, S 760
		from Chassis No. 118 000 001		M 87, M 88, M 137, M 139; M 23: 113, 117, 151
		from Chassis No. 110 2000 001		111, 112, 115, 116
		from Chassis No. 111 2000 001		M 1/M 87, M 1/M 88, M 1, M 108, M 110, M 1/M 23: 113, 117, 151
		Single circuit disc brakes from Chassis No. 117 000 001 up to 117 999 000		113, 114, 117, 118
		Dual circuit disc brakes from Chassis No. 117 000 001 up to 117 999 000		141-144, 151, 152; S 759
		from Chassis No. 118 000 001		113, 114, 117, 118, 141-144, 151, 152; M 23: 151; M 11: 141, 143
		from Chassis No. 111 2000 001		M 1: 113, 114, 117, 118
		from Chassis No. 119 000 001 up to 110 3100 000		M 87/M 80: 113, 114, 117, 118
		from Chassis No. 111 2000 001		M 1/M 87/M 80: 113, 114, 117, 118

**BRAKE MASTER CYLINDER**

(1)	113-611-617D	Tandem master cylinder 19.05 .....		
		(Dual circuit drum brakes: LHD)		
		from Chassis No. 117 000 001 up to 110 3100 000	1	
	113 611 015 B D	from Chassis No. 111 2000 001 up to 111 3200 000	1	111, 115;
		(use:		M 1/M 137: 113, 117
		113 945 515 C		M 1/M 88: 113, 117
		and for M 50, M 601, M 602:		
		113 945 515 D)		



Key No.	Part No.	Description	Quantity	Type and model
(1)	113 611 017 E	Tandem master cylinder 19.05 ..... (Dual circuit disc brakes: LHD) from Chassis No. 117 000 001 up to 110 3100 000 from Chassis No. 111 2000 001 up to 111 3200 000 (use: 113 945 515 C and for M 50, M 601, M 602: 113 945 515 D)	1 1	M 1: 113, 117; 141, 143 M 1/M 80/M 88: 113, 117
(2)	113 611 017 F	Tandem master cylinder 19.05 ..... (Dual circuit disc brakes: LHD) from Chassis No. 111 2000 001 up to 111 3200 000	1	113, 117, 151 M 80/M 87: 113, 117, 151 M 80/M 88: 113, 117, 151
(2)	113 611 017 G *	Tandem master cylinder 19.05 ..... (Dual circuit drum brakes: LHD) from Chassis No. 111 2000 001 up to 111 3200 000	1	M 137: 113, 117, 151
(2)	113 611 017 H	Tandem master cylinder 19.05 ..... (Dual circuit disc brakes: LHD) from Chassis No. 112 2000 001	1	113, 117, 151 M 80/M 87: 113, 117, 151 M 80/M 88: 113, 117, 151
(1)	113 611 017 J	Tandem master cylinder 19.05 ..... (Dual circuit disc brakes: LHD) from Chassis No. 112 2000 001	1	M 1: 113, 117; 141, 143 M 1/M 80/M 88: 113, 117
1	113 611 017 K	Tandem master cylinder 19.05 ..... (Dual circuit drum brakes: LHD) from Chassis No. 112 2000 001	1	111, 115; M 1/M 137: 113, 117 M 1/M 88: 113, 117
2	113 611 017 L	Tandem master cylinder 19.05 ..... (Dual circuit drum brakes: LHD) from Chassis No. 112 2000 001	1	M 137: 113, 117, 151
(1)	114 611 017 D	Tandem master cylinder 19.05 ..... (Dual circuit drum brakes: RHD) from Chassis No. 117 000 001 up to 110 3100 000 from Chassis No. 111 2000 001 up to 111 3200 000 (use: 113 945 515 C and for M 50, M 601, M 602: 113 945 515 D)	1 1	112, 116; M 1/M 137: 114, 118 M 1/M 88: 114, 118
(1)	114 611 017 E	Tandem master cylinder 19.05 ..... (Dual circuit disc brakes: RHD) from Chassis No. 117 000 001 up to 110 3100 000 from Chassis No. 111 2000 001 up to 111 3200 000 (use: 113 945 515 C and for M 50, M 601, M 602: 113 945 515 D)	1 1	M 1: 114, 118; 142, 144 M 1/M 80/M 88: 114, 118



Key No.	Part No.	Description	Quantity	Type and model
(2)	114 611 017 F	Tandem master cylinder 19.05 ..... (Dual circuit disc brakes: RHD) from Chassis No. 111 2000 001 up to 111 3200 000	1	114, 118, 152 M 80/M 87: 114, 118, 152 M 80/M 88: 114, 118, 152
(2)	114 611 017 G *	Tandem master cylinder 19.05 ..... (Dual circuit drum brakes: RHD) from Chassis No. 111 2000 001 up to 111 3200 000	1	M 137: 114, 118, 152
(2)	114 611 017 H	Tandem master cylinder 19.05 ..... (Dual circuit disc brakes: RHD) from Chassis No. 112 2000 001	1	114, 118, 152 M 80/M 87: 114, 118, 152 M 80/M 88: 114, 118, 152
(1)	114 611 017 J	Tandem master cylinder 19.05 ..... (Dual circuit disc brakes: RHD) from Chassis No. 112 2000 001	1	M 1: 114, 118; 142, 144 M 1/M 80/M 87: 114, 118 M 1/M 80/M 88: 114, 118
(1)	114 611 017 K	Tandem master cylinder 19.05 ..... (Dual circuit drum brakes: RHD) from Chassis No. 112 2000 001	1	112, 116; M 1/M 137: 114, 118 M 1/M 87: 114, 118 M 1/M 88: 114, 118
(2)	114 611 017 L	Tandem master cylinder 19.05 ..... (Dual circuit drum brakes: RHD) from Chassis No. 112 2000 001	1	M 137: 114, 118, 152
(3)	113 611 021 C <i>up to 64</i>	Brake master cylinder 19.05 ..... (Single circuit drum brakes) from Chassis No. 1 - 167 890 up to 1 - 575 414 use 113 611 301 A) up to Chassis No. 6 502 399	1	
(3)	113 611 023 A	Brake master cylinder 17.46 ..... (Single circuit disc brakes) from Chassis No. 117 000 001 up to 117 999 000	1	
3	113 611 023 B <i>65-66</i>	Brake master cylinder 17.46 ..... (Single circuit drum brakes) from Chassis No. 115 000 001 up to 119 1200 000	1	
(4)	111 698 171 B	Repair kit for brake master cylinder 113 611 021 K (Single circuit disc brakes) from Chassis No. 117 000 001 up to 117 999 000	1	
4	111 698 173 A	Repair kit for brake master cylinder (S) ..... (Single circuit drum brakes) from Chassis No. 115 000 001 up to 119 1200 000	1	
(5)	111 698 181 B *	Repair kit for tandem master cylinder 19.05 (Ate) (Dual circuit brakes) from Chassis No. 117 000 001 up to 110 3100 000 from Chassis No. 111 2000 001	1 1	111, 112, 115, 116, 141-144; M 1, M 108, M 110
5	111 698 181 C	Repair kit for tandem master cylinder 19.05 ..... (Ate) (Dual circuit disc brakes) from Chassis No. 111 2000 001	1	113, 114, 117, 118, 151, 152

Key No.	Part No.	Description	Quantity	Type and model
(4)	111 698 183	Repair kit for tandem master cylinder 19.05 ..... (Single circuit drum brakes) from Chassis No. 1 - 167 890 up to 6 502 399	1	
(5)	111 698 183 A	☆ Repair kit for tandem brake master cylinder 19.05 (S) (Dual circuit brakes) from Chassis No. 117 000 001 up to 110 3100 000 from Chassis No. 111 2000 001	1 1	111, 112, 115, 116, 141-144; M 1, M 108, M 110
(5)	111 698 183 B	☆ Repair kit for tandem master cylinder 19.05 ..... (S) (Dual circuit disc brakes) from Chassis No. 111 2000 001	1	M 87, M 88, M 137
(4)	211 698 201	Repair kit for brake master cylinder 22.2 ..... (Single circuit drum brakes) up to Chassis No. 1 - 167 889	1	
-	111 698 249	☆ Repair kit for warning equipment on tandem ..... master cylinder (Dual circuit brakes) from Chassis No. 118 000 001 up to 118 1016 100 from Chassis No. 118 000 001	1 1	M 601, M 602 M 11, M 23, M 50
6	*113 611 179	Stop washer - Tandem master cylinder ..... (Dual circuit brakes) from Chassis No. 117 000 001	1	
-	211 611 181	☆ Seal - Warning switch ..... from Chassis No. 118 000 001 up to 118 1016 100 from Chassis No. 118 000 001	1 1	M 601, M 602 M 11, M 23, M 50
7	*113 611 185	Lock ring .....	1	
8	113 611 191	Check valve ..... (Dual circuit drum brakes) from Chassis No. 117 000 001	3	
9	113 611 193	Gasket A 12X16 ..... (Dual circuit drum brakes) from Chassis No. 117 000 001	3	
(10)	113 611 195	Boot - Brake master cylinder ..... up to Chassis No. 117 384 750	1	
10	*113 611 195 B	Boot - Brake master cylinder ..... from Chassis No. 117 384 751	1	
11	113 611 203	Spring rear (Dual circuit brakes) (Afe) ..... from Chassis No. 117 000 001	1	
(11)	113 611 203 A	Spring rear (Dual circuit brakes) (S) ..... from Chassis No. 117 000 001	1	

Key No.	Part No.	Description	Quantity	Type and model
12	113 611 205	Spring front (Dual circuit brakes) (Afe) ..... from Chassis No. 117 000 001	1	
(12)	113 611 205 A	Spring front (Dual circuit brakes) (S) ..... from Chassis No. 117 000 001	1	
(13)	113 611 207	Spring rear (Dual circuit brakes) (Afe) ..... from Chassis No. 117 000 001 up to 110 3100 000	2	
13	113 611 207 B	Spring rear (Dual circuit brakes) (Afe) ..... from Chassis No. 111 2000 001	2	
(14)	113 611 209	Stop sleeve 10.5×25 (Afe) ..... (Dual circuit drum brakes) from Chassis No. 117 000 001 up to 110 3100 000 from Chassis No. 111 2000 001 up to 111 3200 000	1 1	111, 112, 115, 116; M 1/M 137, M 1/M 87, M 1/M 88
14	113 611 209 A	Stop sleeve 10.5×23.5 (Afe) ..... (Dual circuit disc brakes) from Chassis No. 117 000 001 up to 110 3100 000 from Chassis No. 111 2000 001 up to 111 3200 000	1 1	141-144; M 1
(14)	113 611 209 B *	Stop sleeve 10.5×25 (S) ..... (Dual circuit drum brakes) from Chassis No. 117 000 001 up to 110 3100 000 from Chassis No. 111 2000 001	1 1	111, 112, 115, 116; M 1/M 87, M 1/M 88, M 1/M 23
(14)	113 611 209 C	Stop sleeve 10.5×23.5 (S) ..... (Dual circuit disc brakes) from Chassis No. 117 000 001	1	
(14)	113 611 209 D	Stop sleeve 10.5×24 (S) ..... (Dual circuit drum brakes) from Chassis No. 111 2000 001	1	M 87, M 88, M 137
(14)	113 611 209 E *	Stop sleeve 11×25.5 (Afe) ..... (Dual circuit drum brakes) from Chassis No. 111 2000 001	1	M 87, M 88, M 137
(14)	113 611 209 F	Stop sleeve 11×23 (Afe) ..... (Dual circuit disc brakes) from Chassis No. 111 2000 001  from Chassis No. 112 2000 001	1 1	113, 114, 117, 118, 151, 152 141-144; M 1
14	113 611 209 G *	Stop sleeve 11×24.5 (Afe) ..... (Dual circuit drum brakes) from Chassis No. 112 2000 001	1	111, 112, 115, 116; M 1/M 137 M 1/M 87, M 1/M 88
15	113 611 211	Screw - Stop sleeve (Afe) ..... (Dual circuit brakes) from Chassis No. 117 000 001	1	



Key No.	Part No.	Description	Quantity	Type and model
(15)	113 611 211 A	Screw - Stop sleeve (S) ..... (Dual circuit brakes) from Chassis No. 117 000 001	1	
(16)	113 611 245	Bolt, hex. head ..... (Dual circuit brakes) from Chassis No. 117 000 001 up to 117 999 000	1	
16	211 611 245 A	Bolt, hex. head (Dual circuit brakes) ..... from Chassis No. 118 000 001	1	
(17)	113 611 829	Distance tube ..... up to Chassis No. 110 3100 000 from Chassis No. 111 2000 001	2 2	111, 112, 115, 116, 141-144; M 1
17	113 611 829 A	Distance tube ..... from Chassis No. 111 2000 001	2	113, 114, 117, 118, 151, 152
(18)	N 10 353 1	Bolt, hex. head M 8×42 ..... from Chassis No. 3 192 507 up to 110 3100 000 from Chassis No. 111 2000 001	2 2	111, 112, 115, 116, 141-144; M 1
18	N 10 369 1	Bolt, hex. head M 8×58 ..... from Chassis No. 111 2000 001	2	113, 114, 117, 118, 151, 152
19	N 12 008 2	Lock washer B 8 ..... from Chassis No. 111 2000 001	2	
20	N 10 350 3	Bolt, hex. head M 8×50 ..... up to Chassis No. 3 192 506	2	
21	N 11 008 8	Nut, hex. M 8 ..... up to Chassis No. 3 192 506	2	

200  
200  
200

(1)



(



1



200  
200  
200

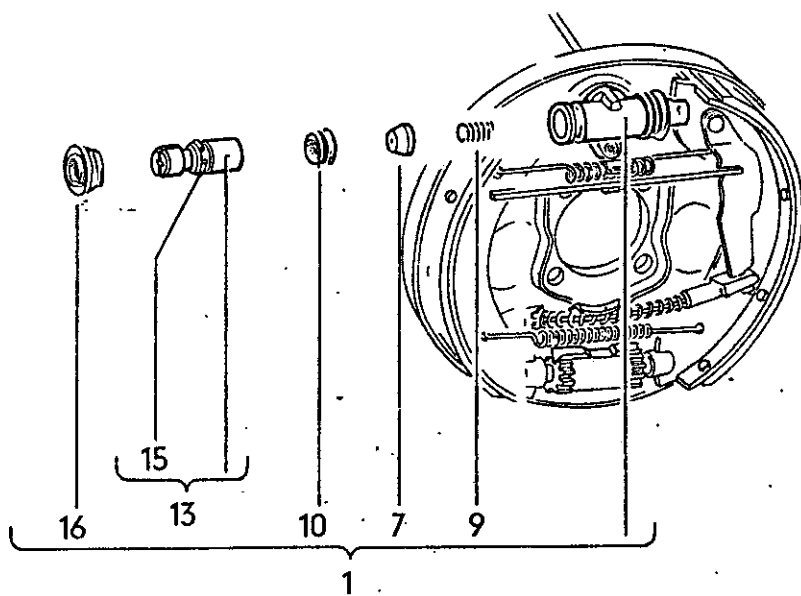
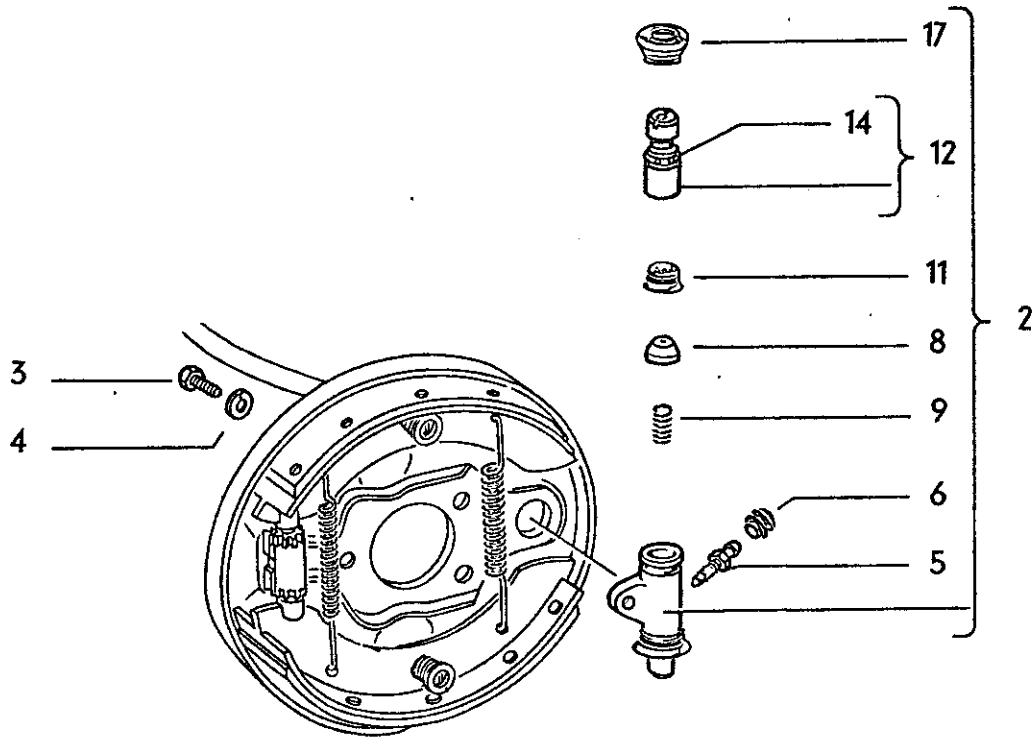

Key No.	Part No.	Description	Quantity	Type and model
<b>CYLINDER - WHEEL BRAKE</b>				
(1)	113 611 051	Cylinder 16 - Rear wheel brake ..... from Chassis No. 1 - 167 890 up to 1 - 397 022	2	
(1)	113 611 053	Cylinder 17.5 - Rear wheel brake ..... from Chassis No. 1 - 397 023 up to 1 673 410	2	
1	113 611 053 B	Cylinder 17.5 - Rear wheel brake ..... from Chassis No. 118 000 001 up to 118 328 505  from Chassis No. 118 328 506	2  2	113, 114, 117, 118, 141-144, 151, 152
(2)	113 611 055	Cylinder 19.05 - Front wheel brake ..... up to Chassis No. 1 673 410 (at rear only up to Chassis No. 1 - 167 889)	2	
(1)	113 611 055 C	Cylinder 19.05 - Rear wheel brake ..... from Chassis No. 1 673 411 up to 6 502 399	2	
(1)	131 611 055	Cylinder 19.05 - Rear wheel brake ..... from Chassis No. 115 000 001 up to 117 999 000 from Chassis No. 118 000 001 up to 118 328 505	2 2	111, 112, 115, 116
(2)	113 611 057 B	Cylinder 22.2 - Front wheel brake ..... from Chassis No. 1 673 411 up to 6 502 399	2	
2	131 611 057	* Cylinder 22.2 - Front wheel brake ..... from Chassis No. 115 000 001 up to 116 1021 300 from Chassis No. 117 000 001 up to 110 3100 000 from Chassis No. 117 000 001  from Chassis No. 111 2000 001	2 2 2 2	M 137 111, 112, 115, 116; M 87, M 88, M 129, M 139 M 1, M 108, M 110
(2)	361 611 067 A	* Cylinder 23.8 - Front wheel brake ..... from Chassis No. 111 2000 001	2	M 87; M 88; M 137
3	N 10 238 7	Bolt, hex. head M 8×15 ..... up to Chassis No. 116 1021 300 from Chassis No. 117 000 001 up to 118 328 505  from Chassis No. 117 000 001 up to 118 328 505  from Chassis No. 118 328 506	4 4  2  2	111, 112, 115, 116; M 87, M 88, M 129, M 137, M 139 113, 114, 117, 118, 141-144, 151, 152



Key No.	Part No.	Description	Quantity	Type and model
4	N 12 008 2	Lock washer B 8 .....	4	
		up to Chassis No. 116 1021 300	4	111, 112, 115, 116;
		from Chassis No. 117 000 001 up to 118 328 505	4	M 87, M 88, M 129,
				M 137, M 139
		from Chassis No. 117 000 001 up to 118 328 505	2	113, 114, 117, 118,
		from Chassis No. 118 328 506	2	141-144, 151, 152
(5)	113 611 475	Bleeder valve with dust cap - .....	4	
		Wheel brake cylinder		
		up to Chassis No. 1 673 410		
5	211 611 477 A	Bleeder valve - Wheel brake cylinder .....		
		Drum brakes:		
		from Chassis No. 1 673 411	4	
		Disc brakes:		
		from Chassis No. 117 000 001	2	
6	*211 611 483	Dust cap - Bleeder valve .....		
		Drum brakes:		
		from Chassis No. 1 673 411	4	
		Disc brakes:		
		from Chassis No. 117 000 001	2	
(7)	113 611 601	Cup expander - Wheel brake cylinder 16 .....	4	
		from Chassis No. 1 - 167 890 up to 1 - 397 022		
(7)	113 611 603	Cup expander - Wheel brake cylinder 17.5 .....	4	
		from Chassis No. 1 - 397 023 up to 1 - 673 410	4	
		from Chassis No. 118 000 001	4	
7	113 611 605	Cup expander - Wheel brake cylinder 19.05 .....	4	
8	211 611 607	Cup expander - Wheel brake cylinder 22.2 .....	4	
		from Chassis No. 1 673 411		
(8)	361 611 607 A *	Cup expander - Wheel brake cylinder 23.8 .....	4	M 87; M 88; M 137
		from Chassis No. 111 2000 001		
9	*113 611 615	Pressure spring - Cup expander .....	4	
		from Chassis No. 1 673 411		
(9)	361 611 615 *	Spring - Cup expander .....	2	M 87; M 88; M 137
		from Chassis No. 111 2000 001		
(10)	*113 611 621	Cup - Wheel brake cylinder 16 .....	4	
		from Chassis No. 1 - 167 890 up to 1 - 397 022		
(10)	*113 611 623	Cup - Wheel brake cylinder 17.5 .....	4	
		from Chassis No. 1 - 397 023 up to 1 673 410	4	
		from Chassis No. 118 000 001	4	



Key No.	Part No.	Description	Quantity	Type and model
10	*113 611 625	Cup - Wheel brake cylinder 19.05 .....	4	
11	*211 611 627	Cup - Wheel brake cylinder 22.2 .....	4	
		from Chassis No. 1 673 411		
(11)	361 611 639 B *	Cup - Wheel brake cylinder 23.8 .....	4	M 87; M 88; M 137
		from Chassis No. 111 2000 001		
(12)	113 611 645	Piston with circlip - Wheel brake cylinder 19.05 ..	4	
		up to Chassis No. 6 502 399		
12	113 611 653	Piston with circlip - Wheel brake cylinder 17.5 ...	4	
		from Chassis No. 118 000 001		
(13)	113 611 657 A	Piston with circlip - Wheel brake cylinder 22.2 ..	4	
		from Chassis No. 1 673 411 up to 6 502 399		
13	311 611 657 E	Piston with circlip - Wheel brake cylinder 22.2 ...	4	
		from Chassis No. 115 000 001		
(12)	131 611 659	Piston with circlip - Wheel brake cylinder 19.05 ..	4	
		from Chassis No. 115 000 001		
(13)	361 611 659 B *	Piston with circlip - Wheel brake cylinder 23.8 ..	4	M 87; M 88; M 137
		from Chassis No. 111 2000 001		
-	113 611 661	Piston - Wheel brake cylinder 16 .....	4	
		from Chassis No. 1 - 167 890 up to 1 - 397 022		
-	113 611 663	Piston - Wheel brake cylinder 17.5 .....	4	
		from Chassis No. 1 - 397 023 up to 1 673 410		
-	113 611 665	Piston - Wheel brake cylinder 19.05 .....	4	
		up to Chassis No. 6 502 399		
-	211 611 667	Piston - Wheel brake cylinder 22.2 .....	4	
		up to Chassis No. 6 502 399		
*				
-	113 611 683	Push rod - Wheel brake cylinder 16 .....	4	
		from Chassis No. 1 - 167 890 up to 1 - 397 022		
-	113 611 687	Push rod - Wheel brake cylinder 17.5/19.05/22.2 .	4	
		from Chassis No. 1 - 397 023 up to 6 502 399		
(15)	113 611 691	Circlip - Piston 113 611 645/131 611 659 .....	4	
(14)	361 611 691 *	Circlip - Piston 361 611 695 B .....	4	M 87; M 88; M 137
		from Chassis No. 111 2000 001		



Key No.	Part No.	Description	Quantity	Type and model
14	113 611 693	* Circlip - Piston 113 611 657 A/311 611 657 E .....	4	M 87; M 88; M 137
		from Chassis No. 1 673 411 up to 111 3100 000	4	
		from Chassis No. 1 673 411	4	
		from Chassis No. 111 2000 001	4	M 1, M 108, M 110
15	113 611 693 A	Circlip - Piston 113 611 653 .....	4	
		from Chassis No. 118 000 001		
16	*113 611 695 D	Boot - Wheel brake cylinder 16/17.5/19.05 .....	4	
		from Chassis No. 1 - 167 890 up to 6 502 399	8	
17	*113 611 695 E	Boot - Wheel brake cylinder 22.2 .....	4	
		from Chassis No. 1 673 411		

(1)

(

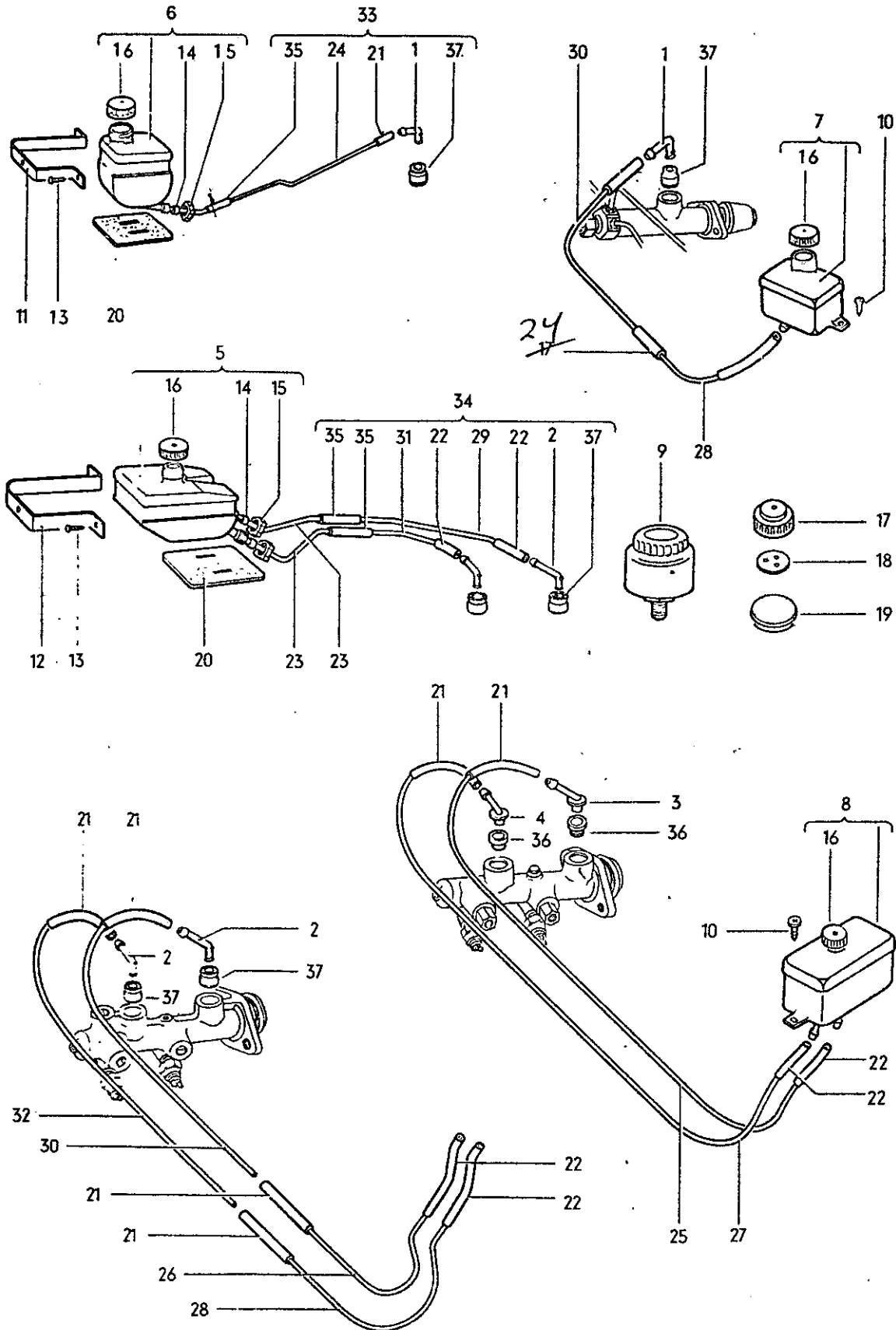

Key No.	Part No.	Description	Quantity	Type and model
<b>RESERVOIR AND LINES – BRAKE MASTER CYLINDER</b>				
1	113 611 153	Elbow 105° – Brake master cylinder ..... from Chassis No. 117 000 001 up to 119 1200 000 from Chassis No. 111 2793 866 up to 111 3200 000	1 1	113, 114, 117, 118, 151, 152
2	113 611 153 A	Elbow 135° – Tandem master cylinder ..... from Chassis No. 117 000 001 up to 111 2793 865 from Chassis No. 111 2793 866 up to 111 3200 000 from Chassis No. 111 2793 866 up to 111 3200 000	2 1 2	113, 114, 117, 118, 151, 152 111, 112, 115, 116; M 1
3	113 611 153 C	Elbow 135° – Tandem master cylinder ..... from Chassis No. 112 2000 001	1 2	113, 114, 117, 118, 151, 152 111, 112, 115, 116; M 1
4	113 611 153 D	Elbow 105° – Tandem master cylinder ..... from Chassis No. 112 2000 001	1	113, 114, 117, 118, 151, 152
(6)	113 611 301 A	Reservoir – Brake master cylinder ..... (Single circuit brakes) up to Chassis No. 3 192 506 (up to Chassis No. 1 – 575 414 use 113 611 021 C)	1	
(6)	113 611 301 G	Reservoir – Brake master cylinder ..... (Single circuit brakes) from Chassis No. 3 192 507 up to 116 1021 300	1	
5	113 611 301 H	Reservoir – Brake master cylinder ..... (Dual circuit brakes) from Chassis No. 117 000 001 up to 117 999 000	1	
6	113 611 301 J	Reservoir – Brake master cylinder ..... (Single circuit brakes) from Chassis No. 117 000 001 up to 117 999 000	1	
(7)	113 611 301 M	Reservoir – Brake master cylinder ..... (Single circuit brakes) from Chassis No. 118 000 001 up to 118 607 339	1	
(8)	113 611 301 N	Reservoir – Tandem master cylinder ..... (Dual circuit brakes) from Chassis No. 118 000 001 up to 118 607 339	1	
7	113 611 301 Q	Reservoir – Brake master cylinder ..... (Single circuit brakes) from Chassis No. 118 607 340 up to 119 1200 000	1	
8	113 611 301 R	Reservoir – Tandem master cylinder ..... (Dual circuit brakes) from Chassis No. 118 607 340	1	

Key No.	Part No.	Description	Quantity	Type and model
9	211 611 301 C	Reservoir - Brake master cylinder ..... (Single circuit brakes) up to Chassis No. 1 - 575 414	1	
10	N 13 957 3	Tapping screw, fillister head BZ 3.5×9.5 ..... from Chassis No. 118 000 001	1	
-	113 611 317 B	Line (50 mm - 1 31/32 in.) - Reservoir 113 611 301 B	1	
11	113 611 331 A	Mounting strap - Reservoir ..... (Single circuit brakes) from Chassis No. 117 000 001 up to 117 999 000	1	
12	113 611 331 B	Mounting strap - Reservoir ..... (Dual circuit brakes) from Chassis No. 117 000 001 up to 117 999 000	1	
13	N 13 958 3	Tapping screw, fillister head B 3.5×13 ..... up to Chassis No. 117 999 000	1	
(14)	113 611 339	Gasket 4.55×9.3×11 - Line ..... from Chassis No. 116 872 032 up to 116 1021 300	1	
14	131 611 339	Gasket 5.85×9.3×11 - Line ..... (Single circuit brakes) ..... 1 (Dual circuit brakes) ..... 2 from Chassis No. 117 000 001 up to 117 999 000		
15	113 955 481	Securing nut - Line ..... (Single circuit brakes) ..... 1 (Dual circuit brakes) ..... 2 from Chassis No. 116 872 032 up to 117 999 000		
16	131 611 349 A 35 04 111 611 349	Screw cap ..... from Chassis No. 116 872 032	1	
17	113 611 351	Screw cap 28 mm dia. .... from Chassis No. 3 192 507 up to 116 872 031	1	
(17)	211 611 351 B	Screw cap 45 mm dia. - Reservoir 211 611 301 A .. up to Chassis No. 1 - 167 889	1	
18	113 611 363	Gasket - Screw cap ..... from Chassis No. 3 192 507 up to 116 872 031	1	
(18)	N 13 827 2	Gasket A 22×27 - Gland nut with strainer ..... up to Chassis No. 1 - 167 889	1	
19	113 611 373	Plug - Reservoir 113 611 301/A/B ..... up to Chassis No. 3 192 506	1	

Key No.	Part No.	Description	Quantity	Type and model
-	N 12 106 1	Spring washer J 6.4 ..... up to Chassis No. 3 192 506	1	
-	N 11 393 1	Tapping screw, cheese head B 5.5×13 ..... up to Chassis No. 3 192 506	1	
20	113 611 399 C	Anli squeak - Reservoir ..... from Chassis No. 3 192 507 up to 117 999 000	1	
(21)	113 611 801 A	Connecting hose 4×2.5 - ..... Line between reservoir and brake master cylinder up to Chassis No. 116 1021 300	1	
(21)	131 611 801	Connecting hose 5.2×2.25 - ..... Lines 6 mm dia. between reservoir and brake master cylinder Single circuit drum brakes: from Chassis No. 117 000 001 up to 117 488 485 Dual circuit brakes: from Chassis No. 117 000 001 up to 117 626 505	1 2	
21	211 611 801 SS N20.350.1	Connecting hose 7.2×2.25 - ..... Lines 8 mm dia. Single circuit brakes: from Chassis No. 117 000 001 up to 117 999 000 from Chassis No. 118 000 001 up to 119 1200 000 Dual circuit brakes: from Chassis No. 117 000 001 up to 117 999 000 from Chassis No. 118 000 001	1 2 2 4	
22	N 20 366 1 SS N20.350.1	Connecting hose 7.3×2.25 ..... between line and reservoir Single circuit brakes: from Chassis No. 118 000 001 Dual circuit brakes: from Chassis No. 118 000 001	1 2	
(24)	113 611 805 C	Line between reservoir and brake master cylinder (Single circuit drum brakes: LHD) up to Chassis No. 116 1021 300	1	111, 113, 115, 117 141, 143, 151
23	113 611 805 F	Line - Reservoir (brake circuit, rear) ..... (Dual circuit brakes: LHD) from Chassis No. 117 000 001 up to 117 999 000	2	
24	*113 611.805 G	Line between reservoir and brake master cylinder (Single circuit brakes: LHD) from Chassis No. 117 000 001 up to 117 999 000	1	



Key No.	Part No.	Description	Quantity	Type and model
(26)	113 611 805 H	Line - Reservoir - Brake circuit, rear ..... (Dual circuit brakes) from Chassis No. 118 000 001 up to 110 3100 000	1	113, 114, 117, 118, 151, 152; M 139
		from Chassis No. 111 2000 001	1	M 1; 111, 112, 115, 116
25	113 611 805 K	Line - Reservoir - Brake circuit, rear ..... (Dual circuit brakes) from Chassis No. 111 2000 001	1	113, 117, 151
26	113 611 805 L	Line - Reservoir - Brake circuit, rear ..... (Dual circuit brakes) from Chassis No. 111 2000 001	1	M 1/M 60; M 60: 111, 112, 115, 116
(24)	114 611 805 B	Line between reservoir and brake master cylinder (Single circuit drum brakes: RHD) up to Chassis No. 116 1021 300	1	112, 114, 116, 118, 142, 144, 152
(24)	114 611 805 E	Line between reservoir and brake master cylinder (Single circuit brakes: RHD) from Chassis No. 117 000 001 up to 117 999 000	1	
(26)	114 611 805 J	Line - Reservoir - Brake circuit, rear ..... (Dual circuit brakes) from Chassis No. 111 2000 001	1	114, 118, 152
(26)	141 611 805	Line for reservoir ..... (Dual circuit brakes: Brake circuit, rear) from Chassis No. 118 000 001	1	141-144
(28)	113 611 806 B	Line - Reservoir ..... Single circuit brake: from Chassis No. 118 000 001 up to 119 1200 000	1	111, 112, 115, 116
		Dual circuit brakes: Brake circuit, front: from Chassis No. 118 000 001 up to 110 3100 000	1	113, 114, 117, 118, 151, 152; M 139
		from Chassis No. 111 2000 001	1	M 1; 111, 112, 115, 116
27	113 611 806 D	Line - Reservoir - Brake circuit, front ..... (Dual circuit brakes) from Chassis No. 111 2000 001	1	113, 117, 151
28	113 611 806 L	Line - Reservoir - Brake circuit, front ..... (Dual circuit brakes) from Chassis No. 111 2000 001	1	M 1/M 60; M 60: 111, 112, 115, 116
(28)	114 611 806 C	Line - Reservoir - Brake circuit, front ..... (Dual circuit brakes) from Chassis No. 111 2000 001	1	114, 118, 152



Key No.	Part No.	Description	Quantity	Type and model
(28)	141 611 806	Line for reservoir ..... (Dual circuit brakes: Brake circuit, front) from Chassis No. 118 000 001	1	141-144
29	113 611 807 A	Line - Tandem master cylinder (LHD) ..... (Dual circuit brakes: brake circuit rear) from Chassis No. 117 000 001 up to 117 999 000	1	
30	113 611 807 B	Line - Brake master cylinder (LHD) ..... Single circuit brakes: from Chassis No. 118 000 001 up to 119 1200 000 Dual circuit brakes, Brake circuit, rear: from Chassis No. 118 000 001 up to 110 3100 000 from Chassis No. 111 2000 001	1 1 1	111, 115 113, 117, 151; M 139: 111, 115 M 1: 113, 117
(29)	*114 611 807 A	Line - Tandem master cylinder (RHD) ..... (Dual circuit brakes: brake circuit rear) from Chassis No. 117 000 001 up to 117 999 000	1	
(30)	114 611 807 B	Line - Brake master cylinder (RHD) ..... Single circuit brakes: from Chassis No. 118 000 001 up to 119 1200 000 Dual circuit brakes, Brake circuit, rear: from Chassis No. 118 000 001 up to 110 3100 000 from Chassis No. 111 2000 001	1 1 1	112, 116 114, 118, 152; M 139: 112, 116 M 1: 114, 118
(30)	114 611 807 D	Line - Tandem master cylinder ..... (Dual circuit brakes: brake circuit rear) from Chassis No. 111 2000 001	1	114, 118, 152
(30)	141 611 807	Line - Tandem master cylinder (LHD) ..... (Dual circuit brakes: brake circuit rear) from Chassis No. 118 000 001	1	141, 143
(30)	142 611 807	Line - Tandem master cylinder (RHD) ..... (Dual circuit brakes: brake circuit rear) from Chassis No. 118 000 001	1	142, 144
31	113 611 808 B	Line - Tandem master cylinder (LHD) ..... (Dual circuit brakes: brake circuit front) from Chassis No. 117 000 001 up to 117 999 000	1	
32	113 611 808 C	Line - Tandem master cylinder (LHD) ..... (Dual circuit brakes: brake circuit front) from Chassis No. 118 000 001 up to 110 3100 000 from Chassis No. 111 2000 001	1 1	113, 117, 151; M 139: 111, 115 M 1: 113, 117
(31)	114 611 808 B	Line - Tandem master cylinder (RHD) ..... (Dual circuit brakes: brake circuit front) from Chassis No. 117 000 001 up to 117 999 000	1	



Key No.	Part No.	Description	Quantity	Type and model
(32)	114 611 808 C	Line - Tandem master cylinder (RHD) ..... (Dual circuit brakes: brake circuit front) from Chassis No. 118 000 001 up to 110 3100 000	1	114, 118, 152; M 139: 112, 116
		from Chassis No. 111 2000 001	1	M 1: 114, 118
(32)	114 611 808 D	Line - Tandem master cylinder ..... (Dual circuit brakes: brake circuit front) from Chassis No. 111 2000 001	1	114, 118, 152
(32)	141 611 808	Line - Tandem master cylinder (LHD) ..... (Dual circuit brakes: brake circuit front) from Chassis No. 118 000 001	1	141, 143
(32)	142 611 808	Line - Tandem master cylinder (RHD) ..... (Dual circuit brakes: brake circuit front) from Chassis No. 118 000 001	1	142, 144
33	113 698 995	Conversion kit for line 8 mm dia. between ..... reservoir and brake master cylinder (Single circuit brakes: LHD) from Chassis No. 117 000 001 up to 117 999 000	1	
34	113 698 995 A	Conversion kit for line 8 mm dia. between ..... reservoir and tandem master cylinder (Dual circuit brakes: LHD) from Chassis No. 117 000 001 up to 117 999 000	1	
(33)	114 698 995	Conversion kit for line 8 mm dia. between ..... reservoir and brake master cylinder (Single circuit brakes: RHD) from Chassis No. 117 000 001 up to 117 999 000	1	
(34)	114 698 995 A	Conversion kit for line 8 mm dia. between ..... reservoir and tandem master cylinder (Dual circuit brakes: RHD) from Chassis No. 117 000 001 up to 117 999 000	1	
-	113 611 811	Washer - Plug (Line 6 mm dia.) ..... Single circuit drum brakes: up to Chassis No. 117 488 185	1	
		Dual circuit brakes: from Chassis No. 117 000 001 up to 117 626 505	2	
(35)	113 611 815	Connecting hose between reservoir and line .... (connection dimensions 6 mm dia. and 8 mm dia.) Single circuit brakes: from Chassis No. 117 000 001 up to 117 999 000	1	
		Dual circuit brakes: from Chassis No. 117 000 001 up to 117 999 000	2	
(37)	113 611 817	Plug - Brake master cylinder ..... up to Chassis No. 116 1021 300	1	

Key No.	Part No.	Description	Quantity	Type and model
36	113 611 817 A	Plug - Brake master cylinder ..... from Chassis No. 112 2000 001	2	
37	311 611 817	Plug - Brake master cylinder (Line 8 mm dia.) .... Single circuit brakes: from Chassis No. 117 000 001 up to 119 1200 000 Dual circuit brakes: from Chassis No. 117 626 506 up to 111 3200 000	1  2	

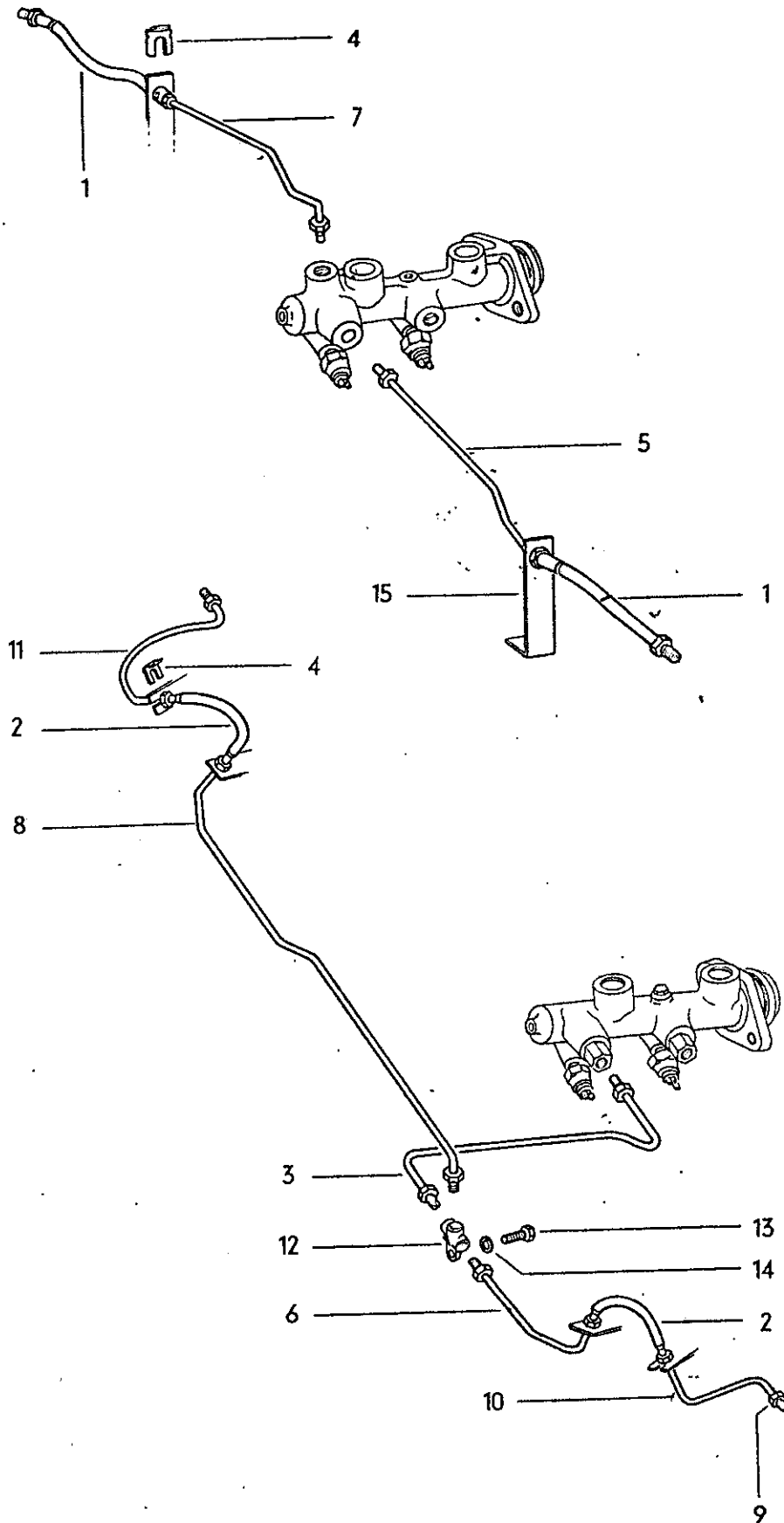

Key No.	Part No.	Description	Quantity	Type and model
<b>FRONT BRAKE CIRCUIT LINES</b>				
(1)	113 611 701	Hose - Front brake (480 mm - 18 <sup>29/32</sup> in.) ..... up to Chassis No. 6 502 399	2	
(1)	211 611 701	Hose - Front brake (440 mm - 17 <sup>9/16</sup> in.) ..... from Chassis No. 115 000 001 up to 116 1021 300	2	
1	311 611 701 A <i>SS by</i> <i>113 611 701 D</i>	Hose - Front brake (380 mm - 14 <sup>31/32</sup> in.) ..... (Drum brakes) from Chassis No. 117 000 001 up to 111 3100 000 from Chassis No. 111 2000 001	2 2	111, 112, 115, 116; M 1
(1)	311 611 701 B	Hose - Front brake (355 mm - 13 <sup>31/32</sup> in.) ..... (Disc brakes) from Chassis No. 117 000 001 up to 110 3100 000 from Chassis No. 111 2000 001	2 2	141-144; M 1
2	113 611 775 B	Hose - Front brake (330 mm - 13 in.) ..... from Chassis No. 111 2000 001	2	113, 114, 117, 118, 151, 152
3	113 611 711 A	Brake line from tandem master cylinder ..... to T-piece front from Chassis No. 111 2000 001	1	113, 117, 151
(3)	114 611 711 A	Brake line from tandem master cylinder ..... to T-piece front from Chassis No. 111 2000 001	1	114, 118, 152
4	113 611 715 A	Bracket - Brake hose .....	6	
-	113 611 723 A	Line - Front brake <i>- ES</i> ..... up to Chassis No. 116 1021 300	1	
(5)	113 611 723 D	Brake line front ..... (Single circuit brakes) from Chassis No. 117 000 001 up to 119 1200 000	1	
5	113 611 723 G	Brake line front ..... (Dual circuit brakes) from Chassis No. 117 000 001 up to 110 3100 000 from Chassis No. 111 2000 001	1 1	111, 112, 115, 116, 141-144; M 1
6	113 611 723 J	Brake line front left from T-piece to hose ..... from Chassis No. 111 2000 001	1	113, 114, 117, 118, 151, 152
(6)	114 611 723 J	Brake line front right from T-piece to hose ..... from Chassis No. 111 2000 001	1	114, 118, 152
(7)	113 611 724 B	Line - Front brake <i>- RS</i> ..... up to Chassis No. 116 1021 300	1	



Key No.	Part No.	Description	Quantity	Type and model
7	113 611 724 C	Brake line front ..... (Dual circuit brakes) from Chassis No. 117 000 001 up to 110 3100 000 from Chassis No. 111 2000 001	1 1	111, 112, 115, 116, 141-144; M 1
(7)	113 611 724 E	Brake line front ..... (Single circuit brakes) from Chassis No. 117 000 001 up to 119 1200 000	1	
8	113 611 724 J	Brake line front right from T-piece to hose ..... from Chassis No. 111 2000 001	1	113, 114, 117, 118, 151, 152
9	113 611 731	Union nut .....	x	
10	113 611 735 B	Brake line front left from hose to calliper ..... from Chassis No. 111 2000 001	1	113, 114, 117, 118, 151, 152
(10)	113 611 735 D *	Brake line front left from hose ..... to wheel brake cylinder from Chassis No. 111 2000 001	1	M 137: 113, 114, 117, 118, 151, 152
11	113 611 736 B	Brake line front right from hose ..... to calliper from Chassis No. 111 2000 001	1	113, 114, 117, 118, 151, 152
(11)	113 611 736 D *	Brake line front right from hose ..... to wheel brake cylinder from Chassis No. 111 2000 001	1	M 137: 113, 114, 117, 118, 151, 152
12	113 611 755	T-piece - Brake lines .....	1	
13	N 10 218 4	Bolt, hex. head BM 6x25 .....	1	
14	N 12 006 2	Lock washer B 6 .....	1	
15	113 611 843 A	Clamp - Brake hose on frame head .....	2	



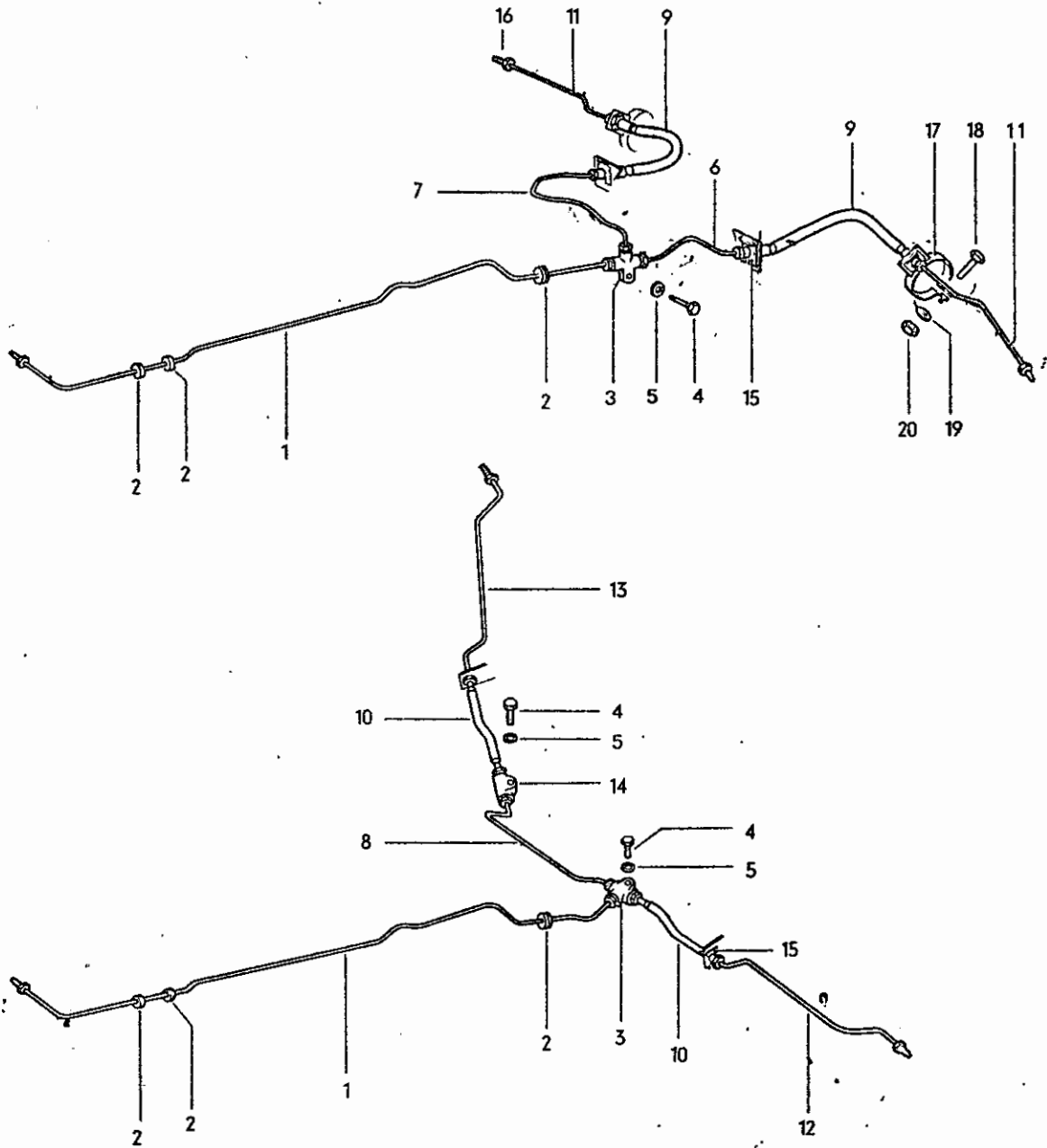



Key No.	Part No.	Description	Quantity	Type and model
<b>REAR BRAKE CIRCUIT LINES</b>				
1	311 611 741	Brake line from brake master cylinder to T-piece	1	
(1)	114 611 741 A	Brake line from brake master cylinder to T-piece (RHD) (Single circuit brakes) up to Chassis No. 119 1200 000	1	
2	211 611 751	Grommet - Brake line	3	
3	113 611 755	T-piece - Brake lines	1	
4	N 10 218 4	Bolt, hex. head BM 6x25	1	
5	N 12 006 2	Lock washer B 6	1	
6	113 611 763 A	Brake line between T-piece and brake hose, rear, left up to Chassis No. 110 3100 000 from Chassis No. 111 2000 001	1 1	M 1; 111, 112, 115, 116
7	113 611 764 B	Brake line between T-piece and brake hose, rear, right up to Chassis No. 110 3100 000 from Chassis No. 111 2000 001	1 1 1	111, 115, 141, 143 113, 117, 151 M 1: 113, 117
8	113 611 764 C	Brake line between T-piece and connecting piece up to Chassis No. 110 3100 000 from Chassis No. 111 2000 001	1 1 1	M 4: 141-144; M 9 M 4 113, 114, 117, 118, 151, 152; M 1/M 4
(7)	114 611 764 B	Brake line between T-piece and brake hose, rear, left (RHD) up to Chassis No. 110 3100 000 from Chassis No. 111 2000 001	1 1 1	112, 116, 142, 144 114, 118, 152 M 1: 114, 118
9	113 611 775	Hose - Rear brake (length 270 mm - 10 <sup>5</sup> / <sub>8</sub> in.) up to Chassis No. 110 3100 000 from Chassis No. 111 2000 001	2 2	111, 112, 115, 116, 141-144; M 1
10	113 611 775 A	Brake hose, rear up to Chassis No. 110 3100 000 from Chassis No. 111 2000 001	2 2 2	M 4: 141-144; M 9 M 4 113, 114, 117, 118, 151, 152; M 1/M 4
(11)	113 611 781	Line - Rear brake, left up to Chassis No. 1 600 439	1	

Key No.	Part No.	Description	Quantity	Type and model
11	113 611 781 D	Brake line rear ..... from Chassis No. 117 000 001 up to 110 3100 000 from Chassis No. 111 2000 001	2 2	111, 112, 115, 116; M 1
(12)	113 611 781 C * <i>SS by</i>	Brake line, rear ..... up to Chassis No. 110 3100 000 from Chassis No. 111 2000 001 up to August 1971	1 1 1	M 4: 141-144; M 9 M 4 113, 114, 117, 118, 151, 152; M 1/M 4
12	113 611 781 E	Brake line, rear ..... from Chassis No. September 1971	1	113, 114, 117, 118, 151, 152; M 1/M 4
(11)	131 611 781	Brake line rear ..... from Chassis No. 1 600 440 up to 4 630 937  from Chassis No. 4 630 938 up to 116 1021 300	2  2	113, 114, 117, 118, 151, 152
(11)	113 611 782	Line - Rear brake, right ..... up to Chassis No. 1 600 439	1	
(13)	113 611 782 B *	Brake line rear right from brake hose to ..... wheel brake cylinder up to Chassis No. 110 3100 000 from Chassis No. 111 2000 001 up to August 1971	1 1 1	M 4: 141-144; M 9 M 4 113, 114, 117, 118, 151, 152; M 1/M 4
13	113 611 782 E	Brake line, rear ..... from Chassis No. September 1971	1	113, 114, 117, 118, 151, 152; M 1/M 4
14	113 611 791 *	Connecting piece - Brake line ..... up to Chassis No. 110 3100 000 from Chassis No. 111 2000 001	1 1 1	M 4: 141-144; M 9 M 4 113, 114, 117, 118, 151, 152; M 1/M 4
15	113 611 715	Bracket - Brake hose .....	1	
16	113 611 731	Union nut .....	x	
17	211 611 841	Clip - Brake hose (rear axle) .....	2	
18	N 10 242 5	Bolt, hex. head M 8x25 .....	2	
19	N 12 008 2	Lock washer B 8 .....	2	
20	N 11 008 8	Nut, hex. M 8 .....	2	



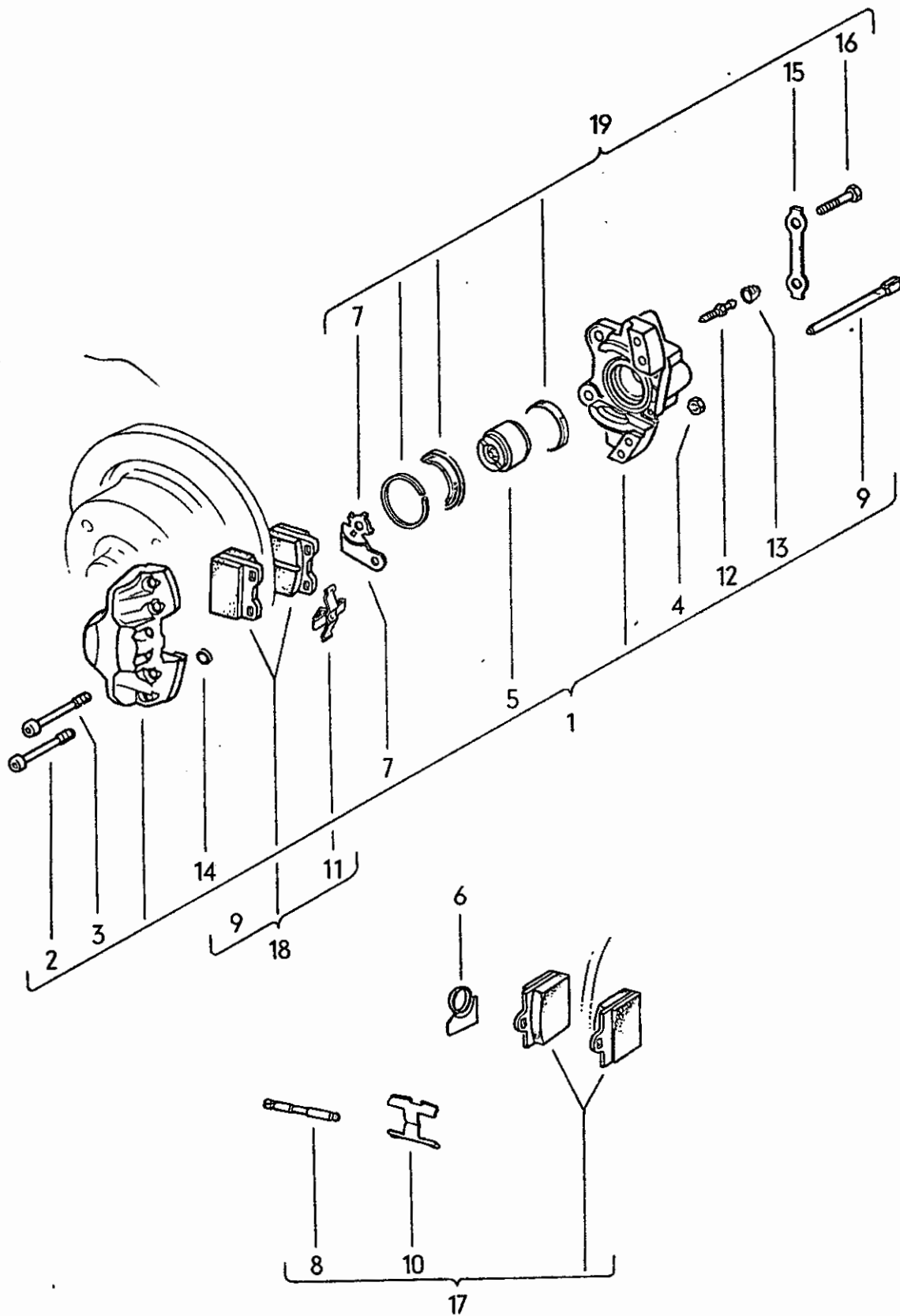

Key No.	Part No.	Description	Quantity	Type and model
<b>DISC BRAKES</b>				
from Chassis No. 117 000 001				113, 114, 117, 118, 141-144, 151, 152
from Chassis No. 119 000 001				M 80, M 1/M 80
(1)	113 615 107	Calliper assembly left without brake pads ..... up to Chassis No. 112 2076 273	1	
1	113 615 107 A	Calliper assembly left without brake pads ..... from Chassis No. 112 2076 274	1	
(1)	113 615 108	Calliper assembly right without brake pads ..... up to Chassis No. 112 2076 273	1	
(1)	113 615 108 A	Calliper assembly right without brake pads ..... from Chassis No. 112 2076 274	1	
2	311 615 141	Securing bolts M 7×45 – Calliper .....	4	
3	411 615 143	Securing bolts M 7×55 – Calliper .....	4	
4	311 615 147	Nut M 7 – Calliper securing bolts .....	8	
5	141 615 155	Piston 40 mm dia. – Calliper .....	4	
(7)	*113 615 231	Piston retaining plate, left ..... from Chassis No. 112 2076 274	1	
6	*141 615 231	Piston retaining plate, left ..... up to Chassis No. 112 2076 273	2	
7	*113 615 232	Piston retaining plate, right ..... from Chassis No. 112 2076 274	1	
(6)	*141 615 232	Piston retaining plate, right ..... up to Chassis No. 112 2076 273	2	
8	*141 615 261	Retaining pin – Brake pad ..... up to Chassis No. 112 2076 273	2	
9	*311 615 261	Retaining pin – Brake pad ..... from Chassis No. 112 2076 274	4	
10	*141 615 269 A	Retaining spring – Brake pad ..... up to Chassis No. 112 2076 273	2	
11	*311 615 269	Retaining spring – Brake pad ..... from Chassis No. 112 2076 274	2	



Key No.	Part No.	Description	Quantity	Type and model
12	311 615 273	Bleeder valve – Calliper .....	2	
		up to Chassis No. 112 2076 273	4	
		from Chassis No. 112 2076 274		
13	211 611 483	Dust cap – Bleeder valve .....	2	
		up to Chassis No. 112 2076 273	4	
		from Chassis No. 112 2076 274		
14	311 615 277	Gasket – Fluid drilling .....	4	
15	*311 615 291	Locking washer – Calliper .....	2	
16	*311 615 293	Securing bolt – Calliper .....	4	
17	111 698 151	Brake pad set .....	1	
		up to Chassis No. 112 2076 273		
18	311 698 151 A	Brake pad set .....	1	
		from Chassis No. 112 2076 274		
(19)	111 698 471	1 set of seals for 1 calliper .....	2	
		up to Chassis No. 112 2076 273		
19	111 698 471 A	1 set of seals for 1 calliper .....	2	
		from Chassis No. 112 2076 274		

Part No.	Description	Quantity
<b>REPAIR KITS</b>		
<b>111 698 051</b>	<b>1 set of brake linings 30</b> up to Chassis No. 1 673 410 front and rear from Chassis No. 1 673 411 up to 117 999 000 rear only from Chassis No. 118 000 001 up to 118 328 505 rear only: 111, 112, 115, 116; M 88	
	comprising:	
	Brake lining 30 .....	4
<b>N 13 634 1</b>	Rivet C 4X7.5 .....	35
<b>111 698 054</b>	<b>1 set of brake linings 30 (0.5 mm oversize)</b> up to Chassis No. 1 673 410 front and rear from Chassis No. 1 673 411 up to 117 999 000 rear only from Chassis No. 118 000 001 up to 118 328 505 rear only: 111, 112, 115, 116; M 88	
	comprising:	
	Brake lining 30 .....	4
<b>N 13 634 1</b>	Rivet C 4X7.5 .....	35
<b>111 698 074</b>	<b>1 set of brake linings 40 (0.5 mm oversize)</b> from Chassis No. 1 673 411 front from Chassis No. 118 000 001 up to 118 328 505 rear: 113, 114, 117, 118, 141-144, 151, 152; M 87 from Chassis No. 118 328 506 rear:	
	comprising:	
	Brake lining 40 .....	4
<b>N 13 634 1</b>	Rivet C 4X7.5 .....	45
<b>111 698 075</b>	<b>1 set of brake linings 40</b> from Chassis No. 1 673 411 front from Chassis No. 118 000 001 up to 118 328 505 rear: 113, 114, 117, 118, 141-144, 151, 152; M 87 from Chassis No. 118 328 506 rear:	
	comprising:	
	Brake lining 40 .....	4
<b>N 13 634 1</b>	Rivet C 4X7.5 .....	45



Part No.	Description	Quantity
311 698 093 A	1 set of brake linings 45 front from Chassis No. 111 2000 001 M 137	
	comprising:	
	Brake lining .....	4
N 13 634 1	Rivet C 4x7.5 .....	40
311 698 096 A	1 set of brake linings 45, front (0.5 mm oversize) from Chassis No. 111 2000 001 M 87, M 88, M 137	
	comprising:	
	Brake lining 45 .....	4
N 13 634 1	Rivet C 4x7.5 .....	40
111 698 151	Brake pad repair kit for caliper assembly from Chassis No. 117 000 001 up to 112 2076 273	
	comprising:	
	Brake pad .....	4
141 615 261	Retaining pin - Brake pad .....	2
141 615 269 A	Spreader spring .....	2
311 698 151 A	Brake pad set from Chassis No. 112 2076 274	
	comprising:	
	Brake pad .....	4
311 615 261	Retaining pin - Brake pad .....	4
311 615 269	Spreader spring - Brake pad .....	2
111 698 171 B	Repair kit for brake master cylinder 17.46 (Single circuit disc brakes) from Chassis No. 117 000 001	
	comprising:	
	Check valve .....	1
	Piston return spring .....	1
	Sleeve .....	1
	Washer .....	1
	Piston .....	1
	Secondary cup .....	1
	Piston stop .....	1
	Lock ring .....	1



Part No.	Description	Quantity
111 698 173 A	<b>Repair kit for brake master cylinder 17.46 (S)</b> (Single circuit drum brakes) from Chassis No. 115 000 001	
	comprising:	
	Check valve .....	1
	Piston return spring .....	1
	Sleeve .....	1
	Piston .....	1
	Washer .....	1
	Secondary cup .....	1
	Piston stop .....	1
	Lock ring .....	1
111 698 181 B	<b>Repair kit for tandem brake master cylinder 19.05 (Ate)</b> (Dual circuit brakes) from Chassis No. 117 000 001 up to 110 3100 000 <i>Custom</i> from Chassis No. 111 2000 001 up to 111 3200 000: 111, 112, 115, 116, 141-144; M 1, M 108, M 110	
	comprising:	
	Primary cup .....	2
	Secondary cup .....	1
	Washer .....	2
	Primary piston .....	1
	Secondary piston .....	1
	Seal .....	1
	Lock ring .....	1
	Ring .....	2
	Separating cup .....	2
111 698 181 C	<b>Repair kit for tandem brake master cylinder 19.05 (Ate)</b> (Dual circuit brakes) from Chassis No. 111 2000 001 up to 111 3200 000: 113, 114, 117, 118, 151, 152 <i>Super</i>	
	comprising:	
	Secondary piston .....	1
	Primary cup .....	1
	Washer .....	2
	Ring .....	2
	Piston .....	1
	Cap .....	1
	Piston stop .....	1
	Separating cup .....	2
113 611 185	Lock ring .....	1
113 611 195 B	Boot .....	1



Part No.	Description	Quantity
311 698 181 C	<b>Repair kit for tandem brake master cylinder 19.05 (Ate)</b> (Dual circuit brakes) from Chassis No. 112 2000 001	
	comprising:	
	Secondary piston .....	1
	Primary cup .....	2
	Washer .....	2
	Ring .....	2
	Piston .....	1
	Cap .....	1
	Piston stop .....	1
	Separating cup .....	2
N 13 804 2	Seal A 6×10 .....	1
113 611 185	Lock ring .....	1
113 611 195 B	Boot .....	1
111 698 183	<b>Repair kit for brake master cylinder 19.05</b> (Single circuit drum brakes) from Chassis No. 1 – 167 890 up to 6 502 399	
	comprising:	
	Check valve .....	1
	Piston return spring .....	1
	Piston .....	1
	Secondary cup .....	2
	Piston stop .....	1
	Lock ring .....	1
	Boot .....	1
111 698 183 A	<b>Repair kit for tandem brake master cylinder 19.05 (S)</b> (Dual circuit brakes) from Chassis No. 117 000 001 up to 110 3100 000	
	(Dual circuit disc brakes) from Chassis No. 111 2000 001	
	comprising:	
	Primary piston with spring rear .....	1
	Secondary piston with spring rear .....	1
	Cap .....	5
111 611 185	Lock ring .....	1
N 13 804 2	Seal A 6×10 .....	1

Part No.	Description	Quantity
111 698 183 B	<b>Repair kit tandem brake master cylinder 19.05 (S)</b> (Dual circuit drum brakes) from Chassis No. 111 2000 001	
<i>super</i>	comprising:	
	Secondary piston with concave washer .....	1
	Primary piston with concave washer .....	1
	Cap .....	5
	Lock ring .....	1
	Piston stop .....	1
	Seal .....	1
211 698 201	<b>Repair kit for brake master cylinder 22.2</b> (Single circuit drum brakes) up to Chassis No. 1 - 167 889	
	comprising:	
	Check valve .....	1
	Piston return spring .....	1
	Main cup .....	1
	Piston .....	1
	Washer .....	1
	Piston stop .....	1
	Lockring .....	1
	Boot .....	1
	Secondary cup .....	1
111 698 249	<b>Repair kit for warning equipment on tandem master cylinder</b> (Dual circuit brakes: M 11, M 23, M 601, M 602) from Chassis No. 118 000 001	
	comprising:	
	Cup .....	2
	Seal .....	2
113 698 251	<b>Repair kit for 1 wheel brake cylinder 16</b> from Chassis No. 1 - 167 890 up to 1 - 397 022	
	comprising:	
211 611 483	Dust cap .....	1
113 611 615	Pressure spring - Cup expander .....	1
113 611 621	Cup .....	2
113 611 695	Boot .....	2



Part No.	Description	Quantity
113 698 261	Repair kit for 1 wheel brake cylinder 17.5 from Chassis No. 1 - 397 023 up to 1 673 410	
	comprising:	
211 611 483	Dust cap .....	1
113 611 615	Pressure spring - Cup expander .....	1
113 611 623	Cup .....	2
113 611 695	Boot .....	2
113 698 261 A	Repair kit for 1 wheel brake cylinder 17.5	
<i>Rear</i>	from Chassis No. 118 000 001 up to 118 328 505:	
<i>FRom 1428</i>	113, 114, 117, 118, 141-144, 151, 152	
	from Chassis No. 118-328 506	
	comprising:	
211 611 483	Dust cap .....	1
113 611 615	Pressure spring - Cup expander .....	1
113 611 623	Cup .....	2
113 611 695 D	Boot .....	2
113 698 273	Repair kit for 1 wheel brake cylinder 19.05	
<i>Rear</i>	up to Chassis No. 117 999 000	
<i>THRU 67</i>	from Chassis No. 118 000 001 up to 118 328 505:	
	111, 112, 115, 116	
	comprising:	
211 611 483	Dust cap .....	1
113 611 615	Pressure spring - Cup expander .....	1
113 611 625	Cup .....	2
113 611 695	Boot .....	2
113 698 293	Repair kit for 1 wheel brake cylinder 22.2	
<i>FRONT</i>	from Chassis No. 1 673 411	
	comprising:	
211 611 483	Dust cap .....	1
113 611 615	Pressure spring - Cup expander .....	1
211 611 627	Cup .....	2
113 611 695 E	Boot .....	2
361 698 301	* Repair kit for 1 wheel brake cylinder 23.8	
	from Chassis No. 111 2000 001	
	M 137	
	comprising:	
361 611 639 B	Cap .....	2
113 611 695 E	Boot .....	2





Part No.	Description	Quantity
<b>111 698 471</b>	<b>1 set of gaskets – 1 calliper assembly</b> from Chassis No. 117 000 001 up to 112 2076 273 113, 114, 117, 118, 141–144, 151, 152; M 80	
	comprising:	
	Seal .....	2
	Boot .....	2
	Clip .....	2
141 615 231	Piston retaining plate .....	1
141 615 232	Piston retaining plate .....	1
311 615 291	Locking washer, calliper .....	1
311 615 293	Bolt, hex. head, calliper assembly .....	2
<b>111 698 471 A</b>	<b>1 set of gaskets – 1 calliper assembly</b> from Chassis No. 112 2076 274 113, 114, 117, 118, 141–144, 151, 152; M 80	
	comprising:	
	Seal .....	2
	Boot .....	2
	Clip .....	2
113 615 231	Piston retaining plate .....	1
113 615 232	Piston retaining plate .....	1
311 615 291	Locking washer, calliper .....	1
311 615 293	Bolt, hex. head, calliper assembly .....	2