

# MAIN GROUP

9

## ELECTRICAL EQUIPMENT

	Illustration
03 Generator	55
05 Ignition	56 + A 56
11 Starting motor	57
15 Battery mounting, Battery cover and circuit breaker	A 57
19 Instruments	58
25 Instrument panel	58
27 Control switch - Automatic	58
37 Fuse box	58
41 Headlamp	59
41 Back-up light, Push-pull type switch, relay	A 59
43 Licence plate light	60
45 Tail light	60
47 Interior light	61
49 Side flashing indicator	61
51 Horn	
53 Direction indicator	
55 Wiper motor-parts	
55 Windshield washer	
55 Wiper motor-parts	
57 Speedometer	
71 Electric wiring	
Installation parts for stationary heater	
Installation parts for safety belt warning system	
98 Repair kits	

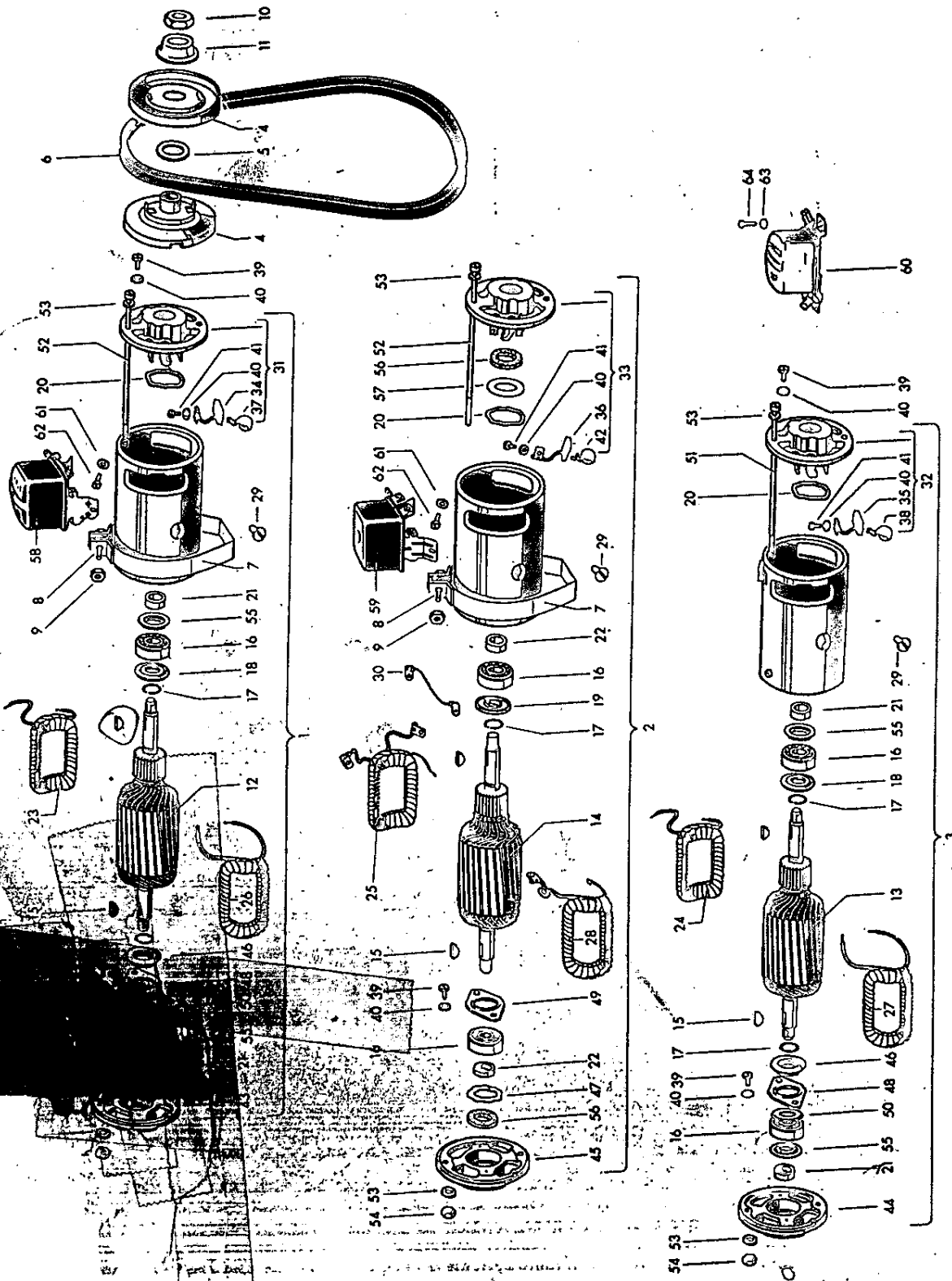

# MAIN GROUP

9

## ELECTRICAL EQUIPMENT

	Illustration
03 Generator	55
05 Ignition	56 + A 56
11 Starting motor	57
15 Battery mounting, Battery cover and circuit breaker	A 57
19 Instruments	58
25 Instrument panel	58
27 Control switch - Automatic	58
37 Fuse box	58
41 Headlamp	59
41 Back-up light, Push-pull type switch, relay	A 59
43 Licence plate light	60
45 Tail light	60
47 Interior light	61
49 Side flashing indicator	61
51 Horn	
53 Direction indicator	
55 Wiper motor-parts	
55 Windshield washer	
55 Wiper motor-parts	
57 Speedometer	
71 Electric wiring	
Installation parts for stationary heater	
Installation parts for safety belt warning system	
98 Repair kits	

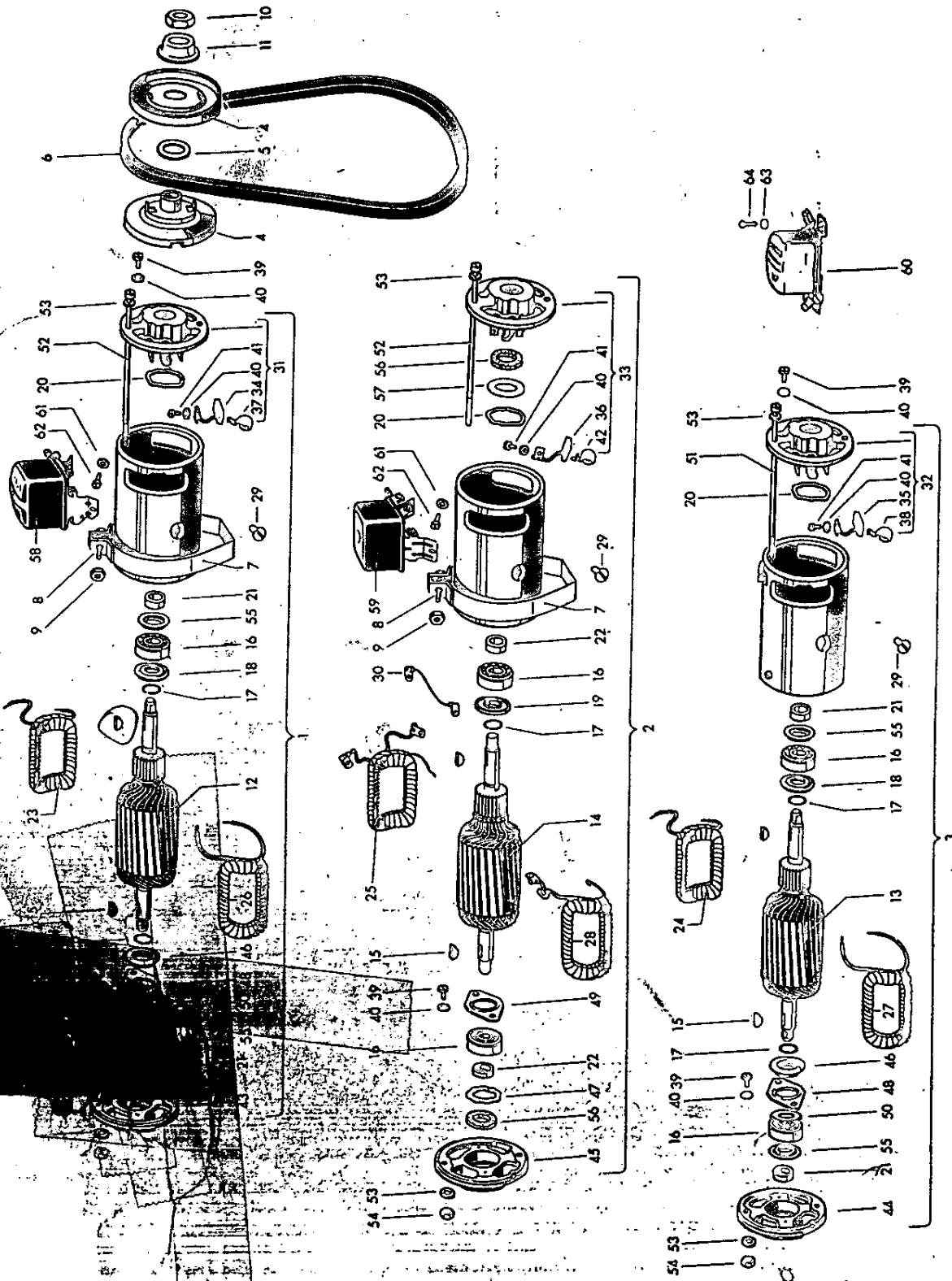

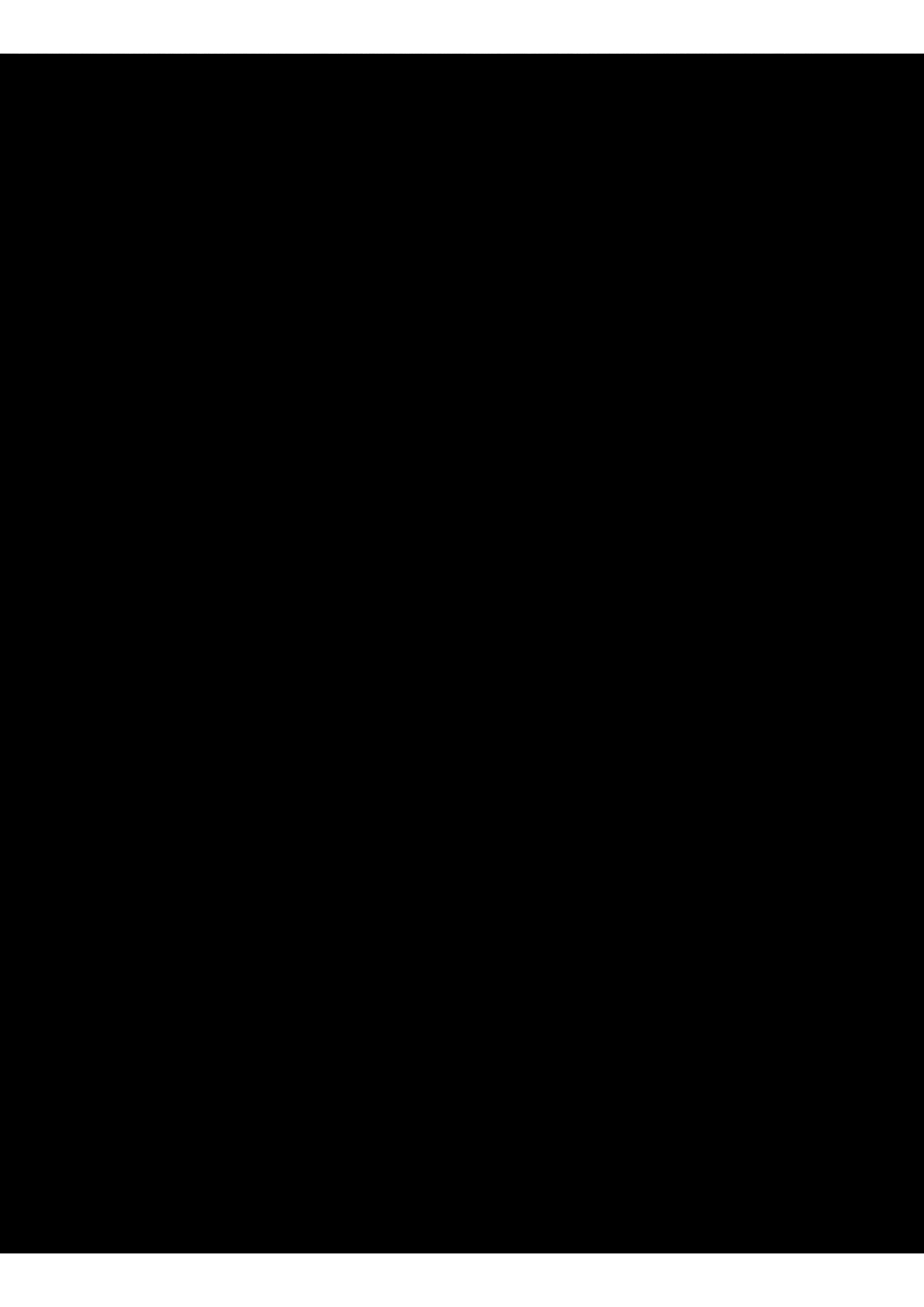

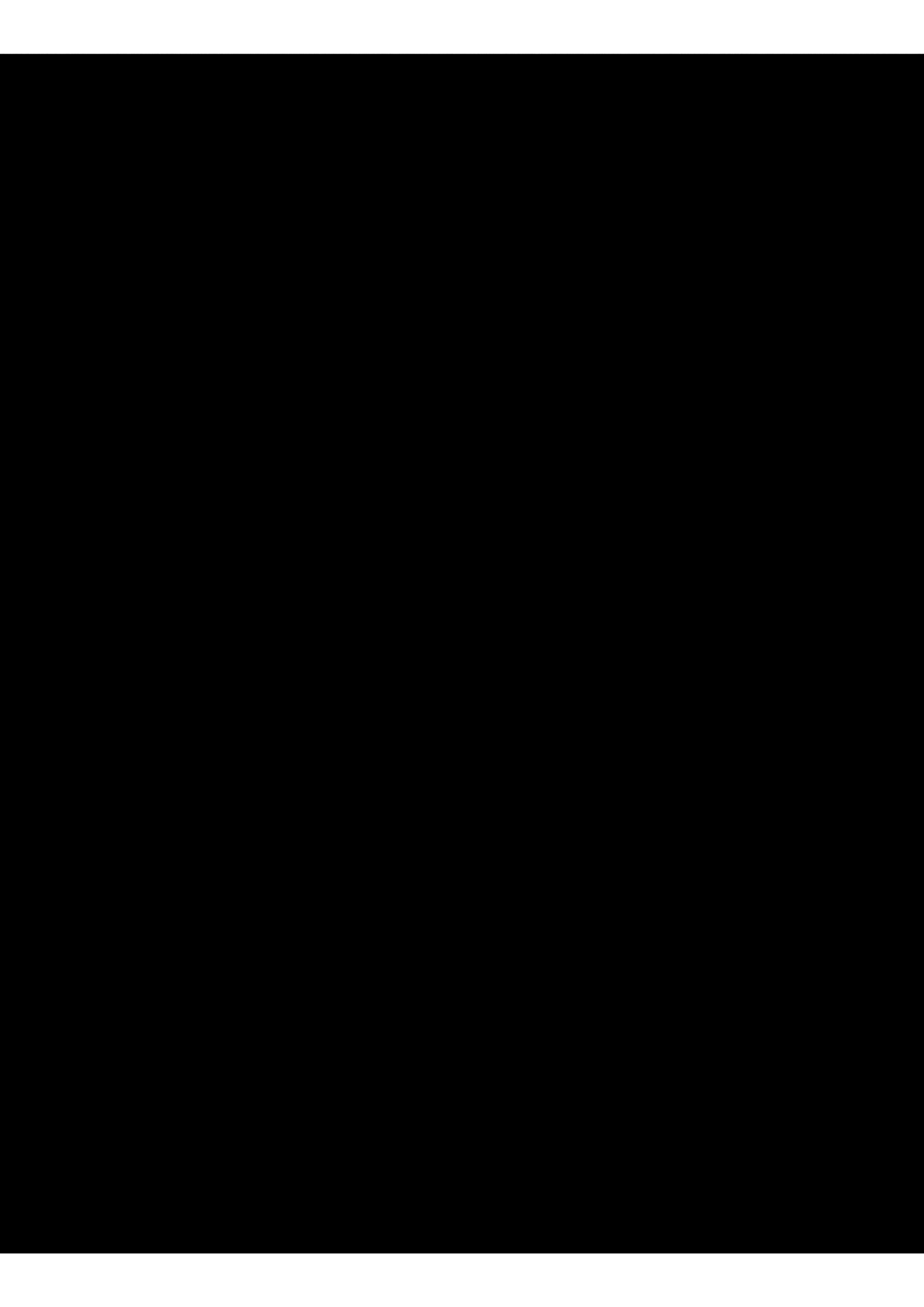

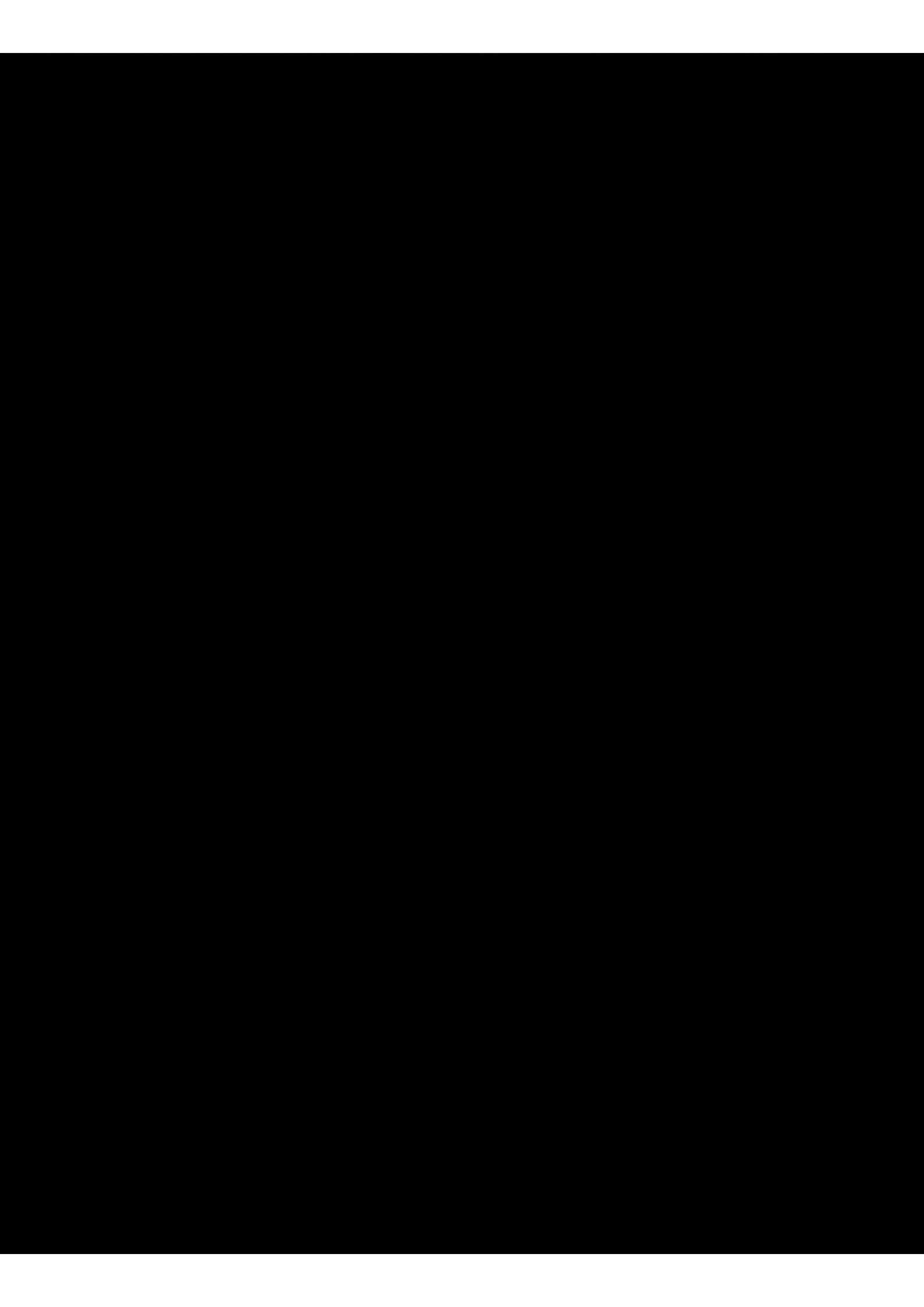

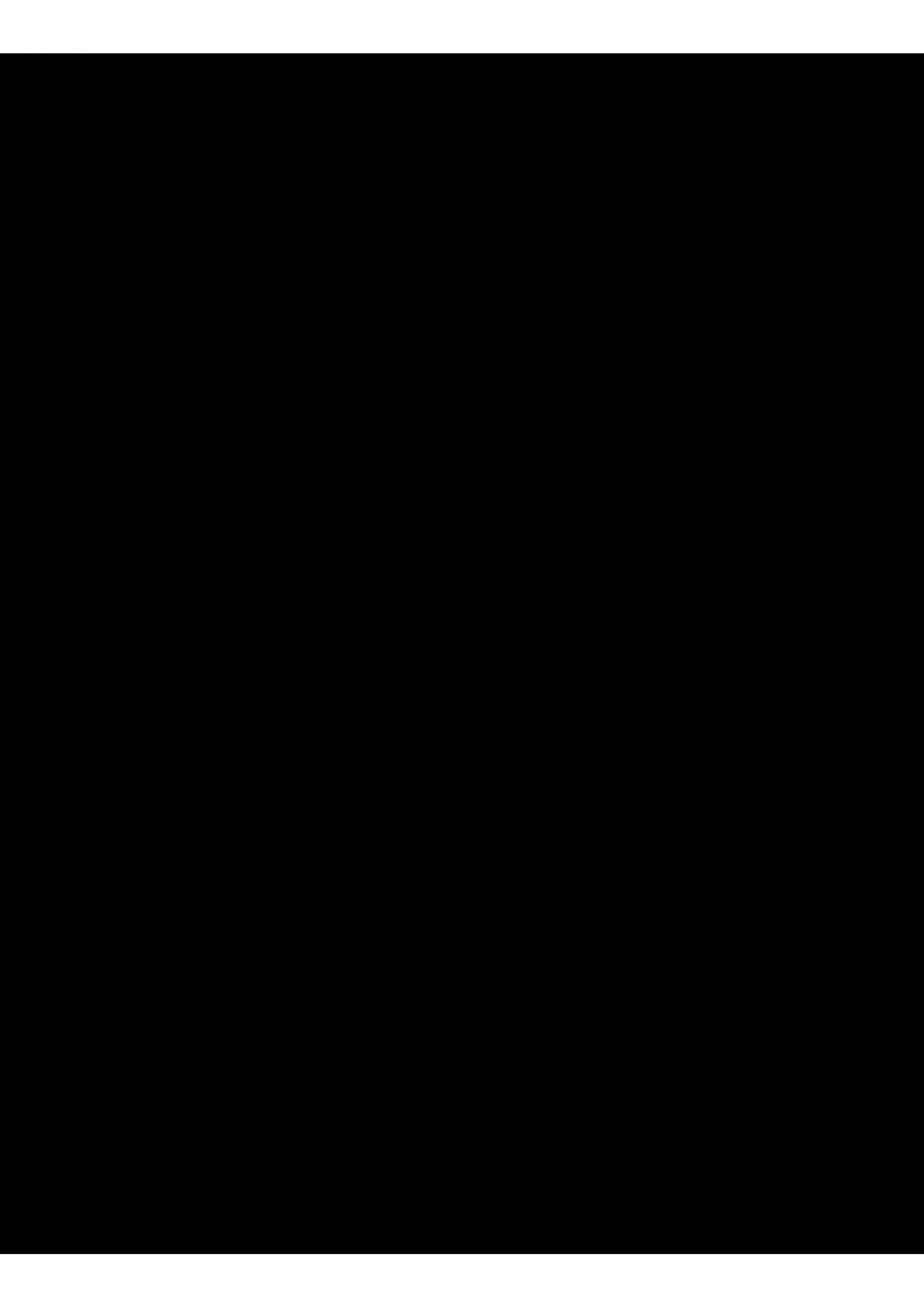

25 DIN b.h.p.=30 SAE , 30=36 , 34=41.5 , 37=47 , 40=49/50 , 44=52/53 , 46=55 , 47=57 , 48=58 , 50=60

No.	Identification	b.h.p.	from Engine No.	to Engine No.	Model	Part No.
25	113 903 031 P (105 mm ø)	34	D 0 838 262		M 88/M 610: 113, 114,	113 903 031 P 117, 118, 151, 152 M 240: 113, 114, 117, 118, 151, 152; M 52/M 240/ M 610: 111, 112, 115, 116 113, 114, 117, 118, 151, 152; M 52/M 610: 111, 112, 115, 116 M 240: 113, 114, 117, 118, 151, 152 M 157: 113, 114, 117, 118, 151, 152 M 27: 113, 114, 117, 118, 151, 152 113, 114, 117, 118, 151, 152 M 157: 113, 114, 117, 118, 151, 152
		40	AC 0 003 792			
		44	AB 0 350 001			
		46	AF 0 000 445			
		48	AE 0 558 001			
		48	AH 0 000 001			
		50	AD 0 252 370			
		50	AE 0 416 836	AE 0 558 000		
26	113 903 031 K (105 mm ø)	34	D 0 719 419	D 0 838 261	M 88/M 610: 113, 114,	113 903 031 P 117, 118, 151, 152 M 240: 113, 114, 117, 118, 151, 152 113, 114, 117, 118, 151, 152 M 240: 141-144 M 157: 141-144 M 27: 141-144 141-144 M 157: 141-144
		40	AC 0 002 749	AC 0 003 791		
		44	AB 0 300 429	AB 0 350 000		
		46	AF 0 000 445			
		48	AE 0 558 001			
		48	AH 0 000 001			
		50	AD 0 252 370			
		50	AE 0 416 836	AE 0 558 000		
27	113 903 031 Q (105 mm ø)	34	D 0 675 000		M 613	113 903 031 P + 311 903 791
		40	AC 0 000 001		M 240/M 613	
		44	AB 0 000 001		M 613	
		46	AF 0 000 001		M 240/M 613	
		48	AE 0 558 001		M 157/M 613	
		48	AH 0 000 001		M 27/M 613	
		50	AD 0 000 001		M 613	
		50	AE 0 000 001	AE 0 558 000		
28	113 903 031 M (105 mm ø)	46	AF 0 000 248	AF 0 000 444	M 240: 113, 114, 117, 118, 141-144, 151, 152	113 903 031 P

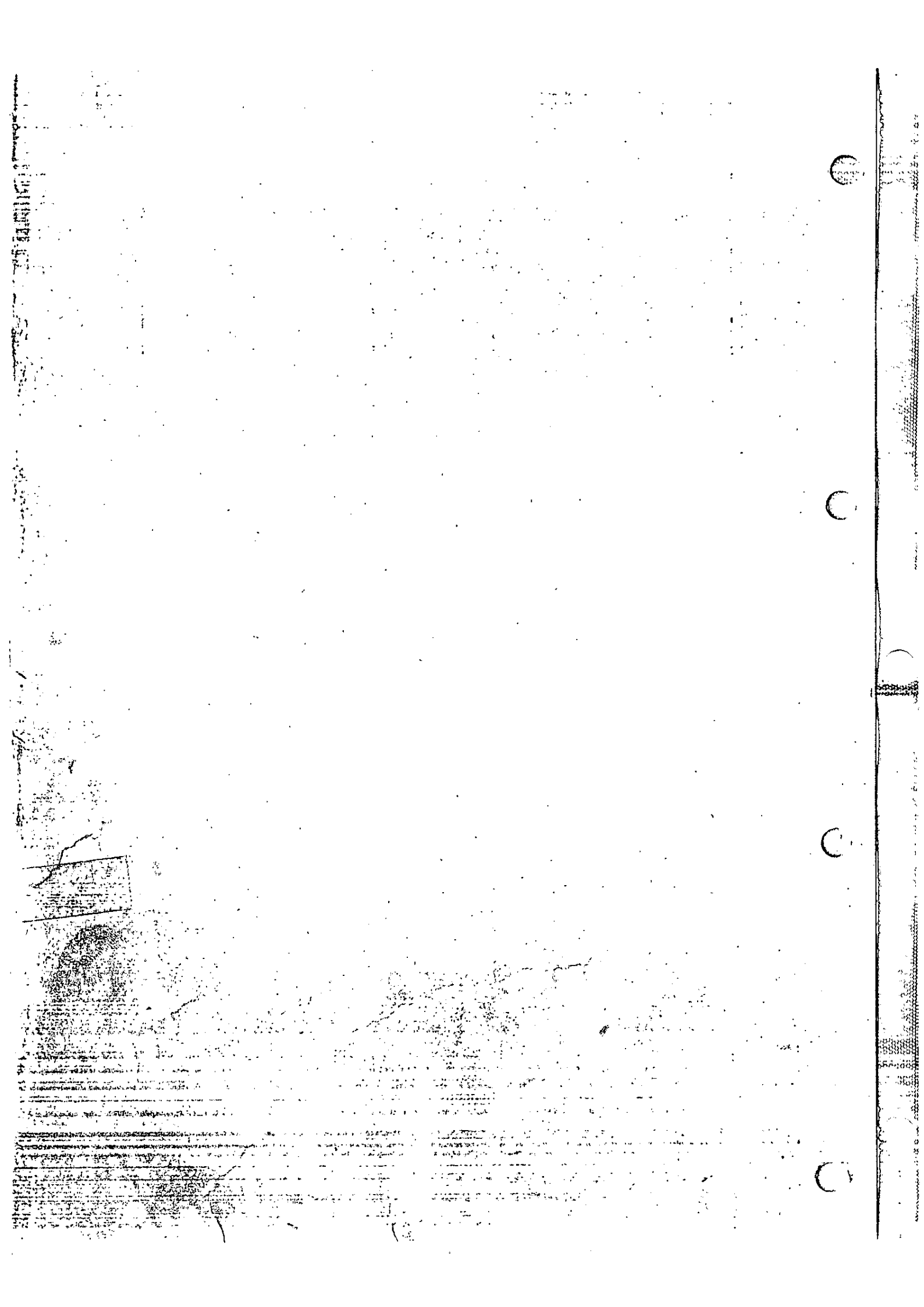

Key No.	Part No.	Description	Quantity	Type and model
---------	----------	-------------	----------	----------------

**GENERATOR  
6 and 12 V**

1	111 903 021 H	Generator 6 V with voltage regulator (90 mm dia.) (Bosch)	1	
---	---------------	---	---	--

2		no longer available: superseded by: 111 903 021 H		
---	--	--	--	--

3	111 903 021 K	Generator 6 V without voltage regulator (105 mm dia.) (Bosch)	1	
---	---------------	---	---	--

(3)	111 903 021 L	Generator 6 V without voltage regulator (105 mm dia.) (Bosch)	1	
-----	---------------	---	---	--

-	113 903 031 E	Generator 12 V without voltage regulator (90 mm dia.) (Bosch) (when installing M 613 use 311 903 791 as well)	1	
---	---------------	--	---	--

-	113 903 031 G	Generator 12 V without voltage regulator (105 mm dia.) (Bosch) use: 311 903 791	1	
---	---------------	---	---	--

-	113 903 031 P	Generator 12 V without voltage regulator (105 mm dia.) (Bosch) use: 311 903 791	1	
---	---------------	---	---	--

**GENERATOR - SINGLE PARTS**

4	111 903 109	Pulley - Generator (13 mm belt) for generator No. 1, 2	1	
---	-------------	--	---	--

-	111 903 109 A	Pulley - Generator (9.5 mm belt) for generator No. 1, 2	1	
---	---------------	---	---	--

-	111 903 109 B	Pulley with hub for generator No. 3, 4	1	
---	---------------	--	---	--

-	111 903 109 C	Pulley with hub for generator No. 5-12, 17-20	1	
---	---------------	---	---	--

-	113 903 109	Pulley with hub for generator No. 8-13, 17-20	1	
---	-------------	---	---	--

-	131 903 109	Pulley with hub for generator No. 14-16, 21-28	1	
---	-------------	--	---	--



Key No.	Part No.	Description	Quantity	Type and model
25 DIN b.h.p.=30 SAE , 30=36 , 34=41.5 , 37=47 , 40=49/50 , 44=52/53 , 46=55 , 47=57 , 48=58 , 50=60				
-	111 903 115	Hub - Pulley ..... for Generator No. 1, 2	1	
-	111 903 123	Distance washer 1.5 mm - Pulley ..... for generator No. 1, 2	6	
5	111 903 131 A	Distance washer 0.5 mm - Pulley ..... x		
-	111 903 137	Belt, width 13 mm .....	1	25 b.h.p.
6	111 903 137 D	Belt, width 9.5 mm .....	1	30, 34-, 37-, 40-, 44-, 46-, 47-, 48-, 50 b.h.p.
7	113 903 141 A	Strap - Generator (90 mm dia.) .....	1	
-	113 903 141 B	Strap - Generator 105 mm dia. ....	1	
8	N 10 242 5	Bolt, hex. head M 8X25 .....	1	
9	N 11 008 8	Nut, hex. M 8 .....	1	
-	111 119 141	Nut - Pulley mounting ..... up to Engine No. 1 - 1 120 614	1	
10	111 903 181	Nut - Pulley mounting ..... from Engine No. 1 - 1 120 615	1	
11	211 903 183	Special washer - Generator ..... from Engine No. 1 - 1 120 615	1	
-	*181 903 197	Cover band - Generator ..... No. 16, 24-28	1	
-	N 13 964 1	Tapping screw, fillister head B 4.2X16 .....	1	
-	111 903 213 C	Armature with ball bearing - Generator 6 V ..... No. 2-5	1	
12	113 903 213	Armature with ball bearing - Generator 6 V ..... No. 1, 6, 8-10, 12	1	
-	113 903 213 A	Armature with ball bearing - Generator 12 V ..... No. 17-20	1	
-	113 903 213 B	Armature with ball bearing - Generator 12 V ..... No. 21-24, 28	1	

Key No.	Part No.	Description	Quantity	Type and model
13	111 903 213 D	Armature with ball bearing – Generator 6 V No. 14, 15, 16	1	
-	113 903 213 D	Armature with ball bearing – Generator 12 V No. 25-27	1	
14	211 903 213	Armature with ball bearing – Generator 6 V No. 7, 11, 13	1	
15	N 12 705 1	Woodruff key 3X5	2	
16	111 903 221 A	Ball bearing – Armature for generator No. 1-28	2	
17	111 903 223	Lockring – Generator No. 1-6, 12, 14, 15, 17-24	2	
18	111 903 225	Oil slinger – Generator No. 1-5	2	
19	211 903 225	Oil slinger – Generator No. 11	1	
20	111 903 235	Spring washer – Generator No. 1-15, 17-24	1	
21	111 903 237	Spacer washer – Generator No. 1-6, 8-10, 12, 14, 15, 17-24	2	
22	211 903 237	Distance ring – Generator No. 7, 11, 13	2	
-	111 903 351 A	Field coil 1 – Generator 6 V No. 1-5	1	
-	111 903 351 B	Field coil 1 – Generator 6 V No. 16	1	
-	113 903 351 A	Field coil 1 – Generator 12 V No. 17-20	1	
23	113 903 351 B	Field coil 1 – Generator 6 V No. 9, 10, 12	1	
-	113 903 351 D	Field coil 1 – Generator 12 V No. 23	1	
-	113 903 351 E	Field coil 1 – Generator 12 V No. 24, 28	1	
-	113 903 351 G	Field coil 1 – Generator 12 V No. 25-27	1	
24	131 903 351	Field coil 1 – Generator 6 V No. 14, 15	1	
-	211 903 351 A	Field coil 1 – Generator 6 V No. 7, 11	1	



Key No.	Part No.	Description	Quantity	Type and model
25	211 903 351 B	Field coil 1 - Generator 6 V No. 13	1	
-	311 903 351	Field coil 1 - Generator 6 V No. 6, 8	1	
-	311 903 351 A	Field coil 1 - Generator 12 V No. 22	1	
-	311 903 351 B	Field coil 1 - Generator 12 V No. 21	1	
-	111 903 353	Field coil 2 - Generator 6 V No. 1	1	
-	111 903 353 B	Field coil 2 - Generator 6 V No. 2-5	1	
-	111 903 353 C	Field coil 2 - Generator 6 V No. 16	1	
-	113 903 353	Field coil 2 - Generator 6 V No. 6, 8	1	
-	113 903 353 A	Field coil 2 - Generator 12 V No. 17-20	1	
26	113 903 353 B	Field coil 2 - Generator 6 V No. 9, 10, 12	1	
-	113 903 353 D	Field coil 2 - Generator 12 V No. 23	1	
-	113 903 353 E	Field coil 2 - Generator 12 V No. 24, 28	1	
-	113 903 353 G	Field coil 2 - Generator 12 V No. 25-27	1	
27	131 903 353	Field coil 2 - Generator 6 V No. 14, 15	1	
-	211 903 353 A	Field coil 2 - Generator 6 V No. 7, 11	1	
28	211 903 353 B	Field coil 2 - Generator 6 V No. 13	1	
-	311 903 353 A	Field coil 2 - Generator 12 V No. 21, 22	1	
29	N 10 999 1	Screw, countersunk head AM 10X13.5	2	
30	211 903 361	Cable - Armature - Generator 6 V No. 13	1	

Key No.	Part No.	Description	Quantity	Type and model
		25 DIN b.h.p.=30 SAE , 30=36 , 34=41.5 , 37=47 , 40=49/50 , 44=52/53 , 46=55 , 47=57 , 48=58 , 50=60		
-	*113 903 365	Insulating washer, outer dia. 13 mm, ..... for generator connection from Chassis No. 111 2000 001 up to 111 3200 000 from Chassis No. 112 2000 001	2 2	46-, 50 b.h.p. 40-, 44-, 46-, 48-, 50 b.h.p.
-	*113 903 367	Insulating washer, outer dia. 15.5 mm, ..... for generator connection from Chassis No. 111 2000 001 up to 111 3200 000 from Chassis No. 112 2000 001	2 2	46-, 50 b.h.p. 40-, 44-, 46-, 48-, 50 b.h.p.
-	111 903 505	End plate with carbon brushes for generator ..... No. 1	1	
31	111 903 505 A	End plate with carbon brushes for generator ..... No. 2-6, 8-10, 12 use for generator No. 9, 10, 12: 211 903 361	1	
-	113 903 505	End plate with carbon brushes for generator 12 V . No. 21, 22, 24-28	1	
-	113 903 505 A	End plate with carbon brushes for generator 12 V No. 23	1	
32	131 903 505	End plate with carbon brushes for generator 6 V . No. 14, 15, 16	1	
33	211 903 505	End plate with carbon brushes for generator 6 V . No. 7, 11, 13	1	
34	111 903 515 A	Carbon brush - Generator 6 V ..... No. 1-6, 8-10, 12	2	
-	111 903 515 B	Carbon brush - Generator 12 V ..... No. 17-20	2	
-	113 903 515 A	Carbon brush - Generator 12 V ..... No. 21-28	2	
35	131 903 515	Carbon brush - Generator 6 V ..... No. 14, 15, 16	2	
36	211 903 515	Carbon brush - Generator 6 V ..... No. 7, 11, 13	2	
37	111 903 519 A	Spring - Brush for generator 6 V ..... No. 1-6, 8-10, 12, 17-20	2	
38	131 903 519	Spring - Brush for generator ..... No. 14, 15, 16, 21-28	2	



Key No.	Part No.	Description	Quantity	Type and model
39	N 10 703 2	Screw, cheese head AM 4x8 up to Chassis No. 6 502 399 from Chassis No. 115 000 001	3 5	
40	N 12 004 1	Lock washer B 4 up to Chassis No. 6 502 399 from Chassis No. 115 000 001	5 4	
41	N 10 695 1	Screw, cheese head AM 4x6	2	
	211 903 519	Spring - Brush (generator) 6 V No. 7, 11, 13	2	
	111 903 537	End plate, fan side for generator 6 V No. 1, 9, 10, 12	1	
	1 903 537 A	End plate, fan side for generator 6 V No. 2-5	1	
	3 537	End plate, fan side for generator 6 V No. 6, 8, 17-20	1	
	A	End plate, fan side for generator 12 V No. 23	1	
		End plate, fan side for generator No. 14, 15, 16, 21, 22, 24	1	
		End plate, fan side for generator 6 V No. 7, 11, 13	1	
		Oil slinger - Generator 6 V No. 1, 6, 8-10, 12, 14, 15, 17-24	1	
	41	Spring washer - Generator No. 2-5	1	
	903 541	Thrust ring - Generator No. 7, 11, 13	1	
	113 903 543	Retaining plate - Generator No. 1, 6, 8-10, 12, 14-28	1	
	211 903 543	Retaining plate - Generator No. 7, 11, 13	1	
	111 903 545	Snap ring - Generator No. 2-5	1	

Key No.	Part No.	Description	Quantity	Type and model
50	113 903 545	Cup washer – Generator ..... No. 1, 6, 8–10, 12, 14, 15, 17–24	1	
51	131 903 555	Bolt – Housing for generator ..... No. 14, 15, 16, 21–28	2	
52	211 903 555	Bolt – Housing for generator ..... No. 1–13, 17–20	2	
53	N 12 226 2	Spring washer B 6 .....	2	
54	N 11 006 2	Nut, hex. M 6 .....	2	
55	111 903 565	Oil slinger for generator ..... No. 1–6, 8–10, 12, 14, 21–24	2	
56	211 903 565	Gasket (felt) – Generator ..... No. 7, 11, 13	2	
57	211 903 567	Retaining ring – Generator ..... No. 7, 11, 13	1	
-	131 903 791	Set of connection parts for terminals DF and D+ – Generator No. 22	1	
-	311 903 791	Suppression casing – Connections – ..... Generator No. 18–21, 27	1	
-	311 903 795	Rubber cap – Terminal – Generator ..... No. 17, 20	1	
-	111 903 801 A	Voltage regulator – Generator 6 V ..... No. 1	1	
-	111 903 801 C	Voltage regulator – Generator 6 V ..... No. 2–5	1	
-	113 903 801 C	Voltage regulator – Generator 6 V ..... No. 7, 11	1	
-	113 903 801 E	Voltage regulator – Generator 6 V ..... No. 6, 8–10	1	
58	113 903 801 F	Voltage regulator – Generator 6 V ..... No. 12	1	
59	113 903 801 G	Voltage regulator – Generator 6 V ..... No. 13	1	

Key No.	Part No.	Description	Quantity	Type and model
60	111 903 801 D	Voltage regulator – Generator 6 V ..... No. 14, 15 use: 111 971 945 B/2×111 971 949	1	
-	113 903 803 C	Voltage regulator – Generator 12 V ..... No. 18, 19	1	
-	113 903 803 D	Voltage regulator – Generator 12 V ..... No. 21	1	
-	113 903 803 E	Voltage regulator – Generator 12 V ..... No. 22-28 use: 111 971 945 B/2×111 971 949	1	
-	211 903 803 E	Voltage regulator – Generator 12 V ..... No. 17, 20 use: 111 971 945 B	1	
61	N 12 005 1	Lock washer B 5 ..... up to Chassis No. 6 502 399 up to Chassis No. 116 1021 300	2 2	141-144 111-118, 151, 152
62	N 10 811 1	Screw, fillister head AM 5×8 ..... up to Chassis No. 6 502 399 up to Chassis No. 116 1021 300	2 2	141-144 111-118, 151, 152
63	N 12 225 1	Spring washer B 5 ..... from Chassis No. 115 000 001 up to 116 1021 300 from Chassis No. 117 000 001	2 2	141-144
64	N 15 892 2	Tapping screw, fillister head A 4.9×19 ..... from Chassis No. 115 000 001 up to 116 1021 300 from Chassis No. 117 000 001	2 2	141-144
-	N 14 130 1	Screw, fillister head AM 5×11 ..... 1	1	
-	N 11 115 1	Nut, hex. BM 5 ..... 1	1	



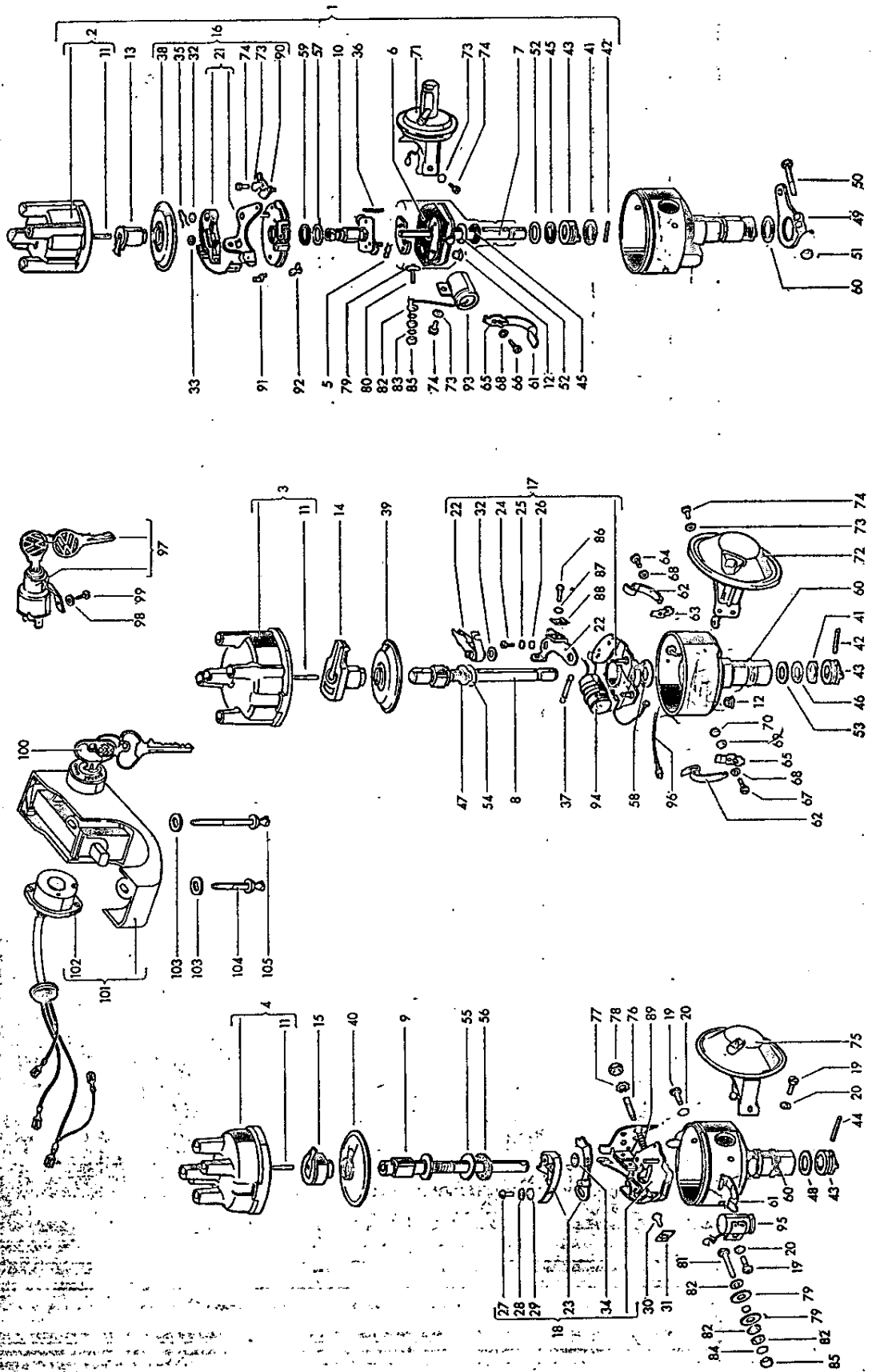



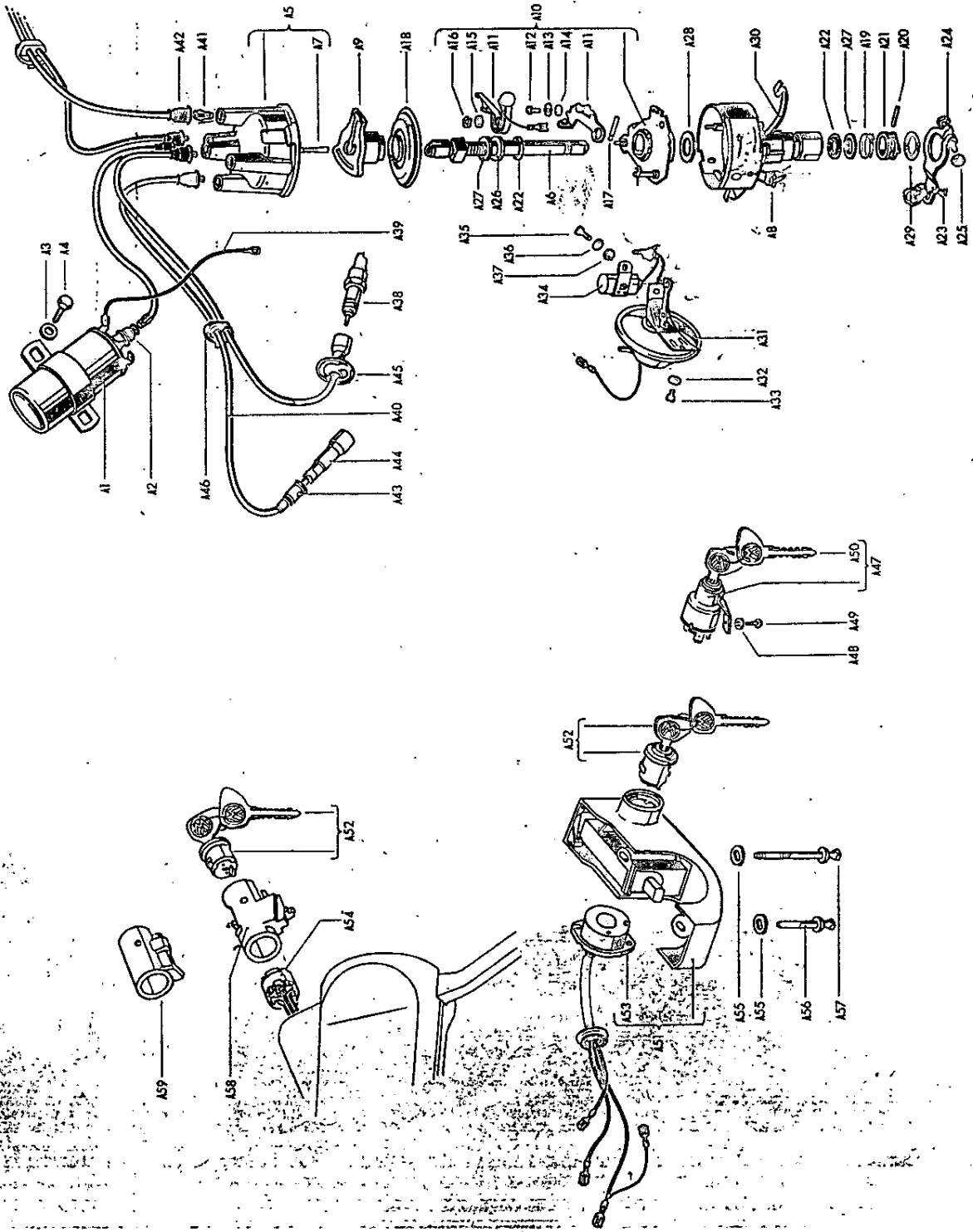

25 DIN.b.h.p.=30 SAE , 30=38 , 34=41.5 , 37=47 , 40=49/50 , 44=52/53 , 46=55 , 47=57 , 48=58 , 50=60

DISTRIBUTOR VERSIONS

No.	Identification	b.h.p.	from Engine No.	to Engine No.	Model	Part No.
1	211 905 205 E VJR 4 BR 8/1	25		1-695 281		211 905 205 F
2	211 905 205 F VJR 4 BR 25/1	25		1-695 281		211 905 205 F
3	111 905 205 VE 4 BRS 383	30	1-695 282	3 912 903	111-118, 151, 152	111 905 205 F
4	111 905 205 C VJU 4 BR 8/1	30	1-695 282	3 912 903	111-118, 151, 152	111 905 205 F
5	111 905 205 F VJUR 4 BR 8/1	30 30	1-695 282	3 912 903 3 072 319	111-118, 151, 152 141, 143	111 905 205 F
6	141 905 205 ZV/JUR 4 R 1	30	3 072 320	3 912 903	141-144	315 905 205 B
7	113 905 205 A ZV/PAU 4 R 2 ZV/PAU 4 R 5	30 34	3 912 904 5 000 001	4 050 000 9 800 000	111, 112, 115, 116 113, 114, 117, 118, 151, 152	315 905 205 B
8	113 905 205 B	30 34	3 912 904 5 000 001	4 050 000 9 800 000	111, 112, 115, 116 113, 114, 117, 118, 151, 152	315 905 205 B
9	311 905 205 ZV/PAU 4 R 4 ZV/PAU 4 R 6	30 34	3 912 904 5 000 001	3 970 440 8 350 309	111, 112, 115, 116 113, 114, 117, 118, 151, 152	315 905 205 B
10	111 905 205 L ZV/JU 4 R 3	30 34	3 912 904 8 350 310	4 050 000 9 800 000	111, 112, 115, 116 113, 114, 117, 118, 151, 152	315 905 205 B
		34	D 0 000 001	D 0 095 049	111, 112, 115, 116	
		34	D 0 095 050	D 0 234 014	M 88, M 129	



25 DIN b.h.p.=30 SAE , 30=36 , 34=41.5 , 37=47 , 40=49/50 , 44=52/53 , 46=55 , 47=57 , 48=58 , 50=60

No.	Identification	b.h.p.	from Engine No.	to Engine No.	Model	Part No.
11	111 905 205 N ZV/JU 4 R 6	30	3 912 904	4 050 000	111, 112, 115, 116	315 905 205 B
		34	8 350 310	9 800 000	113, 114, 117, 118, 151, 152	
		34	D 0 000 001	D 0 095 049	111, 112, 115, 116	
		34	D 0 095 050	D 0 234 014	M 88, M 129	
12	111 905 205 M ZV/JU 4 R 8	30	3 912 904	4 050 000	111, 112, 115, 116	315 905 205 B
		34	8 350 310	9 800 000	113, 114, 117, 118, 151, 152	
		34	D 0 000 001	D 0 095 049	111, 112, 115, 116	
		34	D 0 095 050	D 0 234 014	M 88, M 129	
13	113 905 205 J	30	3 972 441	4 050 000	111, 112, 115, 116	315 905 205 B
		34	8 796 623	9 800 000	113, 114, 117, 118, 151, 152	
		34	D 0 000 001	D 0 095 049	111, 112, 115, 116	
		34	D 0 095 050	D 0 284 014	M 88, M 129	
14	111 905 205 H ZV/PAU 4 R 1	34	5 000 001	9 800 000	141-144	315 905 205 B
15	113 905 205 K	37	E 0 000 001	E 0 006 000	M 240: 113, 114, 117, 118, 141-144, 151, 152	315 905 205 B
		37	E 0 006 001	E 0 015 981	M 240: 111, 112, 115, 116; M 87/M 240, M 129/M 240	
		40	F 0 940 717	F 1 462 598	111, 112, 115, 116; M 87, M 129	
		40	F 0 000 001	F 0 940 716	113, 114, 117, 118, 141-144, 151, 152	
		40	F 0 940 717	F 1 462 598	111, 112, 115, 116; M 87	
16	113 905 205 L	37	E 0 000 001	E 0 006 000	M 240: 113, 114, 117, 118, 141-144, 151, 152	315 905 205 B
		37	E 0 006 001	E 0 015 981	M 240: 111, 112, 115, 116; M 87/M 240	
		40	F 0 000 001	F 0 940 716	113, 114, 117, 118, 141-144, 151, 152	
		40	F 0 940 717	F 1 462 598	111, 112, 115, 116; M 87	
		40	L 0 000 001	L 0 021 115	M 240: 113, 114, 117, 118, 151, 152	
		44	H 0 204 001	H 1 003 255	113, 114, 117, 118, 151, 152	
17	315 905 205	34	D 0 234 015	D 0 382 979	M 240: 113, 114, 117, 118, 141-144, 151, 152	315 905 205 B
		40	L 0 000 001	L 0 021 115	113, 114, 117, 118, 141-144, 151, 152	
		44	H 0 204 001	H 1 003 255	113, 114, 117, 118, 141-144, 151, 152	
18	113 905 205 M	44	H 5 000 001	H 5 414 585	M 157	111 905 205 AA
19	113 905 205 P	40	L 0 019 430	L 0 021 115	M 9/M 240	113 905 205 AA
		44	H 0 879 927	H 1 003 255	M 9	
		44	H 5 077 366	H 5 414 585	M 9/M 157	

*Vallbomgen  
Sliter*

*Boch  
Sliter*

25 DIN b.h.p.=30 SAE , 30=36 , 34=41.5 , 37=47 , 40=49/50 , 44=52/53 , 46=55 , 47=57 , 48=58 , 50=60

No.	Identification	b.h.p.	from Engine No.	to Engine No.	Model	Part No.
20	113 905 205 AA	40	L 0 021 116	L 0 024 106	M 9/M 240	113 905 205 AA
		44	H 1 003 256	H 1 124 668	M 9	
		44	H 5 414 586	H 5 900 000	M 9/M 157	
21	113 905 205 AB	37	E 0 015 982	E 0 020 021	M 9/M 87/M 240	113 905 205 AC
		40	F 1 462 599	F 1 778 163	M 9/M 87	
22	111 905 205 T	34	D 0 382 980	D 0 674 999		315 905 205 B
		37	E 0 015 982	E 0 022 000		
		40	F 1 462 599	F 2 200 000		
		40	L 0 021 116	L 0 026 500		
		44	H 1 003 256	H 1 350 000		
23	315 905 205 B ♦	30	3 072 320	4 050 600		315 905 205 B
		34	5 000 001	D 0 674 999		
		37	E 0 000 001	E 0 022 000		
		40	F 0 000 001	F 2 200 000		
		40	L 0 000 001	L 0 026 500		
		44	H 0 204 001	H 1 350 000		
24	113 905 205 T	44	H 5 414 586	H 5 900 000	M 157	111 905 205 AA
		47	B 6 000 001	B 6 600 000	M 157, M 527	
25	113 905 205 AC	37	E 0 020 022	E 0 022 000	M 9/M 52/M 240/M 610,	113 905 205 AC
		40	F 1 778 164	F 2 200 000	M 9/M 87/M 240	
		40	L 0 024 107	L 0 026 500	M 9/M 52/M 610,	
		44	H 1 124 669	H 1 350 000	M 9/M 87 M 9/M 240 M 9	
26	113 905 205 AD	47	B 6 000 001	B 6 600 000	M 9/M 157	113 905 205 AE
27	113 905 205 AE	47	B 6 000 001	B 6 600 000	M 9/M 157	113 905 205 AE
28	111 905 205 AA	34	D 0 675 000			111 905 205 AA
29	113 905 205 AH	48	AE 0 000 001		M 9/M 26/M 157	113 905 205 AH
		48	AH 0 000 001		M 9/M 26/M 27/M 157	
30	113 905 205 AJ	40	AC 0 000 001	AC May 1971	M 87/M 240	113 905 205 AJ
		44	AB 0 000 001	AB May 1971	M 87	
		46	AF 0 000 001	AF May 1971	M 240	
		48	AE 0 000 001	AE July 1971	M 26/M 157	
		50	AD 0 000 001	AD May 1971	113, 114, 117, 118, 141-144, 151, 152	
31	113 905 205 AK	40	AC 0 000 001	AC May 1971	M 9/M 87/M 240	113 905 205 AK
		44	AB 0 000 001	AB May 1971	M 9/M 87	
		46	AF 0 000 001	AF May 1971	M 9/M 240	
		50	AD 0 000 001	AD May 1971	M 9	

♦ This distributor was not a standard fitting and is used for repairs only.

Typ 1-5

Illustration —

25 DIN b.h.p.=30 SAE , 30=36 , 34=41.5 , 37=47 , 40=49/50 , 44=52/53 , 46=55 , 47=57 , 48=58 , 50=60

No.	Identification	b.h.p.	from Engine No.	to Engine No.	Model	Part No.
32	113 905 205 AL	40 44 46 50	AC June 1971 AB June 1971 AF June 1971 AD June 1971		M 87/M 240 M 87 M 240 113, 114, 117, 118, 141-144, 151, 152	113 905 205 AL
33	113 905 205 AM	40 44 46 50	AC June 1971 AB June 1971 AF June 1971 AD June 1971		M 9/M 87/M 240 M 9/M 87 M 9/M 240 M 9	113 905 205 AM
34	113 905 205 AN	48	AE August 1971		M 26/M 157	113 905 205 AN

Key No.	Part No.	Description	Quantity	Type and model
<b>COIL, DISTRIBUTOR</b>				
A 1	111 905 105 H	Heavy - duty coil 6 V .....	1	
-	113 905 115 C	Coil 12 V (Bosch) .....	1	
A 2	311 905 429 A	Cap (rubber) - Coil .....	1	
A 3	N 11 695 2	Washer 6.1 .....	2	
A 4	N 10 210 7	Bolt, hex. head M 6X10 .....	2	
-	211 905 205 F	Distributor (screened) .....	1	
1	111 905 205 F	Distributor (screened) .....	1	
-	111 905 205 AA	Distributor .....	1	
-	113 905 205 AA *	Ignition distributor (Bosch) .....	1	
-	113 905 205 AC	Distributor .....	1	
-	113 905 205 AE *	Distributor .....	1	
-	113 905 205 AH *	Distributor .....	1	
-	113 905 205 AJ	Distributor .....	1	
-	113 905 205 AK	Distributor .....	1	
-	113 905 205 AL	Distributor .....	1	
-	113 905 205 AM	Distributor .....	1	
-	113 905 205 AN	Distributor .....	1	
-	315 905 205 B	Ignition distributor .....	1	

Key No.	Part No.	Description	Quantity	Type and model
<b>DISTRIBUTOR PARTS</b>				
-	111 905 207	Distributor cap with cover - Distributor 3 .....	1	
-	111 905 207 A	Distributor cap ..... for screening distributor 3 (for use with 111 905 225 A only)	1	
2	111 905 207 B	Distributor cap - Distributors 1, 2, 4-6 .....	1	
A 5	111 905 207 C	Distributor cap - Distributors 10-12, 15, 17, 18 ...	1	
3	113 905 207	Distributor cap - Distributors 7, 9, 14 .....	1	
-	113 905 207 A	Distributor cap - Distributors 20-34 .....	1	
4	211 905 207	Distributor cap - Distributors 8, 13, 16 .....	1	
-	341 905 207	Distributor cap - Distributor 19 .....	1	
5	111 905 211	Spring clip for centrifugal weights - ..... Distributors 3, 4	2	
6	111 905 213	Damping plate - Distributors 1, 2, 4, 5 .....	1	
7	111 905 217	Distributor shaft - Distributors 1, 4, 5 .....	1	
A 6	111 905 217 A	Distributor shaft with cams - Distributors 10-12, 15	1	
8	113 905 217 A	Distributor shaft with cams - Distributors 7, 9 ....	1	
9	211 905 217 A	Distributor shaft with cams - Distributors 8, 13, 16	1	
10	111 905 219	Distributor cam - Distributors 4, 5 .....	1	
	211 905 219	Distributor cam - Distributors 1, 2 .....	1	
11/A 7	111 905 221 A	Carbon brush with spring - Distributors 7, 9 .....	1	

**MAIN GROUP**



**ELECTRICAL EQUIPMENT**

Key No.	Part No.	Description	Quantity	Type and model
12/A 8	111 905 223	Safety screen – Distributors 6, 7, 9	1	
-	111 905 225	Rotor – Distributor 3	1	
-	111 905 225 A	Rotor (screened) – Distributor 3 (for use with 111 905 207 A only)	1	
13	111 905 225 C	Rotor (screened) – Distributors 1, 2, 4-6	1	
A 9	111 905 225 F	Rotor (screened) – Distributors 10-12, 15, 17-19	1	
14	113 905 225 A	Rotor (screened) – Distributors 7, 9, 14	1	
15	113 905 225 B	Rotor (screened) – Distributors 8, 13, 16	1	
-	113 905 225 E	Rotor (screened) – Distributors 20-25, 27-34	1	
-	113 905 225 F	Rotor (screened) with speed limiter 4 800 r.p.m. – Distributors 23, 24, 26	1	
-	111 905 227	Contact breaker plate with distributor contacts – Distributors 1-3	1	
16	111 905 227 A	Contact breaker plate with distributor contacts – Distributors 4, 5	1	
A 10		no longer available		
17	311 905 227	Contact breaker plate with distributor contacts – Distributors 7, 9	1	
18	211 905 227 A	Contact breaker plate with distributor contacts – Distributors 8, 13	1	
-	211 905 227 B	Contact breaker plate with distributor contacts – Distributor 16	1	
19	N 10 697 1	Screw, cheese head AM 4X10	3	
20	N 12 121 2	Shake-proof washer A 4.3	3	

Typ 1-10

Illustration **56 + A 56**

Key No.	Part No.	Description	Quantity	Type and model
-	111 998 051	1 set of breaker points - Distributors 1-3	1	
21	111 998 053	1 set of breaker points - Distributors 4, 5	1	
-	111 998 055	1 set of breaker points - Distributor 6	1	
22	111 998 057	1 set of contact breakers - Distributors 7, 9, 14	1	
A 11	111 998 059	1 set of contact breakers - Distributors 10-12, 15-17	1	
23	111 998 061	1 set of contact breakers - Distributors 8, 13, 16	1	
-	111 998 063	1 set of breaker points for distributors 18, 22-24	1	
-	311 998 063	1 set of breaker points - Distributors 19-21, 25-27, 29-34	1	
24	N 10 695 1	Screw, cheese head AM 4x6	1	
25	N 12 004 1	Lock washer B 4	1	
26	N 11 555 1	Washer 4.3	1	
27/A 12	N 11 246 1	Screw, button head AM 4x6	1	
28/A 13	N 12 121 2	Shake-proof washer A 4.3	1	
29/A 14	N 11 555 1	Washer 4.3	1	
30	N 10 260 1	Bolt, hex. head M 4x4	1	
31	211 905 277	Lock plate - Distributors 8, 13, 16	1	
32/A 15	111905 231	Shim 0.2 mm - Contact breaker arm - Distributors 3, 4, 6, 7, 9-12, 14, 15	1	
A 16	N 12 433 1	Spring washer 3.2 - Distributors	1	

**MAIN GROUP**



**ELECTRICAL EQUIPMENT**

Key No.	Part No.	Description	Quantity	Type and model
33	N 11 555 1	Washer 4.3	1	
34	211 905 231	Insulating disc - Contact breaker arm - Distributors 8, 13, 16	1	
35	N 12 433 1	Spring washer 3,2 - Distributors 4-6	1	
36	111 905 237 A	Tension spring - Distributors 1, 4, 5, 24	2	
-	111 905 237 B	Distributor contact breaker plate return spring - Distributors 10-12	1	
A 17	111 905 237 C	Distributor contact breaker plate return spring - Distributors 15, 17, 22, 23	2	
37	113 905 237	Distributor contact breaker plate return spring - Distributors 7, 9, 14	1	
-	113 905 237 A	Distributor contact breaker plate return spring - Distributor 18	1	
38/A 18	111 905 241 E	Sealing disc - Distributors 1, 2, 4, 5, 10-12, 15	1	
39	113 905 241	Sealing disc - Distributors 7, 9, 14	1	
40	211 905 241	Sealing disc - Distributors 8, 13, 16	1	
41/A 19	111 905 243	Lockring - Dog - Distributors 3, 4, 6, 7, 9-12, 14	1	
42/A 20	111 905 245	Pin - Dog - Distributors 3, 4, 6, 7, 9-12, 14	1	
43/A 21	111 905 247	Driving dog - Distributors 3, 4, 6, 7, 9-15, 17-27	1	
44	N 13 217 1	Dowel pin 4x20	1	
45/46/ A 22	111 905 249	Distance washer - Distributors 3, 4, 6, 7, 9-12, 14, 15	2	
47	113 905 249	Distance washer, upper - Distributors 7, 9, 14	1	

Typ 1-5

Illustration

**56 + A 56**

Key No.	Part No.	Description	Quantity	Type and model
25 DIN b.h.p.=30 SAE , 30=36 , 34=41.5 , 37=47 , 40=49/50 , 44=52/53 , 46=55 , 47=57 , 48=58 , 50=60				
48	211 905 249	Distance washer – Dog – Distributors 8, 13, 16	1	
A 23	113 905 250	Retainer – Distributor	1	34-, 37-, 40-, 44-, 46-, 47-, 48-, 50 b.h.p.
49	111 905 251	Retainer – Distributor	1	25, 30 b.h.p.
-	N 12 241 2	Spring washer B 8×15 – Distributor	1	
-	N 11 008 8	Nut, hex. M 8	1	
50/A 24	N 10 346 2	Bolt, hex. head M 6×30	1	
51/A 25	N 11 006 2	Nut, hex. M 6	1	
52/53/ A 26	111 905 255	Spacer, lower on distributor shaft – Distributors 3, 4, 6, 7, 9-12, 14, 15	1	
54/A 27	113 905 255	Spacer, upper and lower on distributor shaft – Distributors 7, 9-12, 14, 15	2	
55	211 905 255 A	Thrust washer, upper – Distributors 8, 13, 16	1	
56	211 905 255 B	Thrust washer, lower – Distributors 8, 13, 16	1	
57	111 905 257	Shim plate (0.3 mm) on cam – Distributor 4	x	
A 28	111 905 257 A	Spacer 0.1 mm between contact breaker plate and distributor housing – Distributors 10-12, 15	x	
58	113 905 257	Spacer between contact breaker plate and distributor housing – Distributors 7, 9, 14	1	
59	111 905 259	Fibre shim on cam – Distributors 3, 4	1	
60/A 29	111 905 261	Sealing ring – Distributors 1-31	1	
61	111 905 265	Spring – Retainer for distributor cap – Distributors 3, 6, 8, 13, 16	2	
A 30		discontinued: no replacement		

MAIN GROUP



ELECTRICAL EQUIPMENT

Key No.	Part No.	Description	Quantity	Type and model
62	113 905 265	Spring - Retainer for distributor cap - Distributors 7, 9, 14	2	
63	111 905 269	Clip - Retainer spring mounting - Distributors 3, 6, 7, 9, 14	1	
64	N 10 695 1	Screw, cheese head AM 4x6	1	
65	111 905 270	Clip (with lug) - Retainer spring mounting - Distributors 3, 6	1	
66	N 10 703 2	Screw, cheese head AM 4x8	2	
67	N 10 697 1	Screw, cheese head AM 4x10	1	
68	N 12 004 1	Lock washer B 4	1	
69	N 12 224 1	Spring washer B 4	1	
70	N 11 004 2	Nut, hex. M 4	1	
71	111 905 271 A	Vacuum unit - Distributor 5	1	
-	111 905 271 B	Vacuum unit - Distributors 10-12	1	
-	111 905 271 C	Vacuum unit - Distributor 28	1	
72	113 905 271	Vacuum unit - Distributors 7, 9, 14	1	
-	113 905 271 B	Vacuum unit - Distributors 18, 24	1	
-	113 905 271 C	Vacuum unit - Distributors 19-21, 25	1	
-	113 905 271 D	Vacuum unit - Distributor 26	1	
-	113 905 271 E	Vacuum unit - Distributor 27	1	
-	113 905 271 F	Vacuum unit - Distributors 30, 31	1	

Typ 1-5

Illustration **56 + A56**

Key No.	Part No.	Description	Quantity	Type and model
-	113 905 271 G	Vacuum unit - Distributor 29 .....	1	
-	113 905 271 H	Vacuum unit - Distributors 32, 33 .....	1	
-	113 905 271 J	Vacuum unit - Distributor 34 .....	1	
A 31	311 905 271	Vacuum unit - Distributors 15, 17, 22, 23 .....	1	
73/A 32	N 12 224 1	Spring washer B 4 .....	3	
74/A 33	N 10 695 1	Screw, cheese head AM 4x6 .....	3	
-	141 905 271	Vacuum unit - Distributor 6 .....	1	
-	211 905 271	Vacuum unit - Distributor 13 .....	1	
-	211 905 271 A	Vacuum unit - Distributor 16 .....	1	
75	211 905 271 B	Vacuum unit - Distributors 8, 13 .....	1	
76	N 13 046 1	Stud M 5x18 .....	1	
-	N 10 811 1	Screw, fillister head AM 5x8 .....	1	
77	N 12 104 2	Spring washer A 5.3 .....	1	
78	N 11 005 2	Nut, hex. M 5 .....	1	
79	111 905 273	Insulating washer for condenser connecting - Distributors 3, 4, 6, 8, 13, 16 .....	2	
80	N 10 262 1	Bolt, hex. head M 4x20 .....	1	up to Engine No. 3 912 903
81	N 10 261 1	Bolt, hex. head M 4x15 .....	1	from Engine No. 3 912 904
82	N 11 555 1	Washer 4.3 .....	3	
83	N 12 004 1	Lock washer B 4 .....	2	up to Engine No. 3 912 903
84	N 12 121 2	Shake-proof washer A 4.3 .....	1	

Key No.	Part No.	Description	Quantity	Type and model
85	N 11 004 2	Nut, hex. M 4	2	
86	113 905 275	Bolt, hex. head - Contact breaker arm - Distributors 7, 9, 14	1	
87	N 12 004 1	Lock washer B 4	1	
88	113 905 277	Threaded plate - Distributors 7, 9, 14	1	
89	211 905 279	Return spring - Distributors 8, 13	1	
90	111 905 279	Bracket - Breaker plate - Distributors 4, 5	1	
91	111 905 281	Eccentric bolt - Breaker point - Distributors 4, 5	1	
92	111 905 285	Spring for plunger - Distributors 4, 5	1	
93	111 905 295	Condenser - Distributors 1; 4, 5	1	
A 34	111 905 295 A	Condenser - Distributors 10-12, 15, 22, 24	1	
94	113 905 295	Condenser - Distributors 2, 7, 9, 14	1	
-	113 905 295 B	Condenser - Distributors 19-21, 25	1	
-	113 905 295 C	Condenser - Distributors 29-34	1	
95	211 905 295	Condenser - Distributors 8, 13, 16	1	
-	311 905 295 A	Condenser - Distributors 17, 18, 23, 24, 28	1	
-	311 905 295 B	Condenser - Distributors 26, 27	1	
A 35	N 10 703 2	Screw, cheese head AM 4x8	1	
A 36	N 12 224 1	Spring washer B 4	1	
A 37	N 11 004 2	Nut, hex. M 4	1	
96	311 905 299	Cable - Coil to distributor, with grommet - Distributors 7, 9, 14	1	

Typ 1-5

Illustration **56 + A 56**



Key No.	Part No.	Description	Quantity	Type and model
25 DIN b.h.p.=30 SAE , 30=36 , 34=41.5 , 37=47 , 40=49/50 , 44=52/53 , 46=55 , 47=57 , 48=58 , 50=60				
<b>SPARKING, CONNECTOR - SPARKING PLUG</b>				
-	000 057 001	Sparking plug 145, VW ..... (not for 44 b.h.p.: 1.3 Liter and 50 b.h.p. engines)	4	
A 38	000 057 002	Sparking plug 145, Bosch .....	4	
-	000 057 003	Sparking plug 145, Beru .....	4	
A 39	113 905 421	Cable - Coil to distributors 1-6, 8, 13, 16 .....	1	
A 40	N 18 382 1	Ignition cable from coil to distributor and cylinder	*	
A 41	111 905 427	Connector - Ignition cable .....	6	
A 42	311 905 429 A	Cap (rubber) - Distributor and coil .....	5	
-	311 905 281 A	Suppressor plug - Distributor .....	6	M 123
A 43	311 905 443	Cap - Connector, sparking plug ..... 113 035 255 A	4	
-	311 905 444 A	Cap between sparking plug connector and ..... sparking plug	4	113, 114, 117, 118, 141-144, 151, 152
-	111 905 445	Connector - Sparking plug ..... up to Engine No. 3 604 931	4	
-	111 905 445 A	Spark plug connector - Resistor type ignition cable	4	
A 44	113 035 255 A	Connector (screened) - Sparking plug .....	4	
-	311 905 447	Connector (screened) - Sparking plug .....	4	M 123
A 45	111 905 449	Rubber cap - Sparking plug .....	4	
-	122 905 449 A	Rubber cap - Sparking plug .....	4	M 123
A 46	113 905 451 A	Holder for ignition cable .....	3	

Key No:	Part No.	Description	Quantity	Type and model
-	111 905 471	Clamp, front - Conduit up to Engine No. 2 938 463	2	111-118, 141, 143, 151, 152
-	111 905 475	Clamp, rear - Conduit up to Engine No. 2 938 463	2	111-118, 141, 143, 151, 152
-	N 11 389 1	Tapping screw, cheese head B 4.8x13	2	

IGNITION/STARTER SWITCH,  
STEERING LOCK

-	111 905 801	Ignition switch with keys (A, V, P profile) up to Chassis No. 1 - 397 022	1	111-118, 151, 152
-	111 905 803	Ignition/starter switch with keys (G, SG profile) from Chassis No. 1 - 397 023 up to 1 600 439	1	111-118, 151, 152
97	111 905 803 C <i>USA</i> <i>1957 + HR0-1969</i>	Ignition/starter switch with keys (SC, SU, SV profile) from Chassis No. 3 192 507 up to 116 1021 300	1	111-118, 151, 152
A 47	111 905 803 D <i>USA</i> <i>67</i>	Ignition/starter switch with keys (K profile) from Chassis No. 1 600 440 up to 117 999 000	1	111-118, 151, 152
-	141 905 803	Ignition/starter switch with keys (SG profile) up to Chassis No. 2 528 667	1	141, 143
-	141 905 803 B	Ignition/starter switch with keys (SG profile) from Chassis No. 2 528 668 up to 146 1021 300	1	141-144
-	141 905 803 C	Ignition/starter switch with keys (K profile) from Chassis No. 147 000 001 up to 147 999 000	1	141-144
-	111 905 805 C	Ignition/starter switch with cylinder lock for door handle (SC, SU, SV profile) from Chassis No. 3 192 507 up to 6 502 399 from Chassis No. 115 000 001 up to 116 1021 300	1 1	111-118, 151, 152 111-118
-	111 905 805 D	Ignition/starter switch with 2 cylinder lock for door handle (SC, SU, SV profile) from Chassis No. 5 888 185 up to 6 502 399 from Chassis No. 115 000 001 up to 116 1021 300	1 1	M 21 151, 152; M 21



Key No.	Part No.	Description	Quantity	Type and model
-	111 905 805 E	Ignition/starter switch with cylinder lock ..... for door handle (K profile) from Chassis No. 117 000 001 up to 117 999 000	1	111-118
-	111 905 805 F	Ignition/starter switch with 2 cylinder lock ..... for door handle (K profile) from Chassis No. 117 000.001 up to 117 999 000	1	151, 152; M 21
98/A 48	N 11 523 3	Washer A 5.3 ..... up to Chassis No. 117 999 000	1	
99/A 49	N 14 127 4	Screw, fillister head AM 5x6 ..... up to Chassis No. 117 999 000	1	
100/A 50	111 837 219 A	Key - Ignition (specify key number) ..... S53 profile A S61 profile V No. 1 S62 profile V No. 2 S63 profile V No. 3 S54 profile P S60 profile G, SG S72 profile SE S73 profile SC S74 profile SU S75 profile SV S66 profile K S92 profile M	2	
-	111 905 815	Bakelite coupling - Ignition switch 111 905 801 ... up to Chassis No. 1 - 397 022	1	111-118, 151, 152
-	111 905 817	Spring - Ignition switch 111 905 801 ..... up to Chassis No. 1 - 397 022	1	111-118, 151, 152
-	111 905 819	Contact piece - Ignition switch 111 905 801 ..... up to Chassis No. 1 - 397 022	1	111-118, 151, 152
-	141 905 827	Grommet - Ignition starter switch ..... from Chassis No. 4 400 001 up to 147 999 000	1	141-144
-	111 998 021	Steering lock with ignition starter switch, ..... silver beige for service installation (for RHD from Chassis No. 1 600 440 only) up to Chassis No. 117 999 000	1	111-118, 151, 152
101/A 51	*111 905 851 H	Steering lock with ignition starter switch without ... lock cylinder from Chassis No. 4 010 995 up to 117 999 000 466 silver beige 043 grey-black	1	M 55: 111-118, 151, 152

Key No.	Part No.	Description	Quantity	Type and model
-	111 905 851 L	Steering lock without ignition starter switch and without lock cylinder from Chassis No. 111 2000 001 up to April 1972	1	
-	111 905 851 N	Steering lock without ignition starter switch and without lock cylinder from Chassis No. May 1972	1	
-	141 905 851	Steering lock with ignition starter switch without lock cylinder from Chassis No. 147 000 001 up to 147 999 000	1	M 55: 141-144
A 52	*113 905 853	Lock cylinder with keys for steering lock without ignition starter switch from Chassis No. 117 000 001 up to 117 999 000 from Chassis No. 118 000 001 up to 110 3100 000	1 1	M 55
-	*113 905 855 A <i>SS BY</i> <i>113 905 855 B</i>	Lock cylinder with keys - Ignition starter switch (profile M) from Chassis No. 111 2000 001	1	
-	311 905 855	Lock cylinder with keys up to Chassis No. 110 3100 000	1	M 248
-	111 905 857	Lock cylinder with keys for steering lock without ignition starter switch and lock cylinder with keys for door handle from Chassis No. 117 000 001 up to 117 999 000	1	M 55
-	111 905 859	Fuse box with cover - Steering lock with ignition starter switch up to Chassis No. 3 192 506	1	111-118, 151, 152
-	111 905 861	Cover - Fuse box up to Chassis No. 3 192 506	1	111-118, 151, 152
-	111 905 865 B	Ignition starter switch 28 mm dia. for steering lock from Chassis No. 3 192 507 up to 116 1021 300	1	M 55: 111-118, 151, 152
-	111 905 865 D	Ignition starter switch 28 mm dia. for steering lock from Chassis No. 117 000 001 up to 117 999 000	1	M 55
102/A 53	111 905 865 E	Ignition starter switch 36 mm dia. for steering lock from Chassis No. 3 192 507 up to 117 999 000	1	M 55
-	111 905 865 F	Ignition starter switch from Chassis No. 111 2000 001 up to 111 3200 000 from Chassis No. 142 2000 001	1 1	111, 112, 115, 116



Key No.	Part No.	Description	Quantity	Type and model
-	111 905 865 K	Ignition starter switch ..... from Chassis No. 112 2000 001	1	113, 114, 117, 118, 151, 152, M 1, M 108, M 110
A 54	311 905 865 A	Ignition starter switch ..... from Chassis No. 118 000 001 up to 110 3100 000	1	
-	131 905 867	Covering for steering lock ..... from Chassis No. 117 000 001	1	M 55: 141-144
103/A 55	*111 905 877	Washer - Steering lock mounting .....	1	M 55: 111-118, 151, 152
104/A 56	*111 905 881	Mounting screw 36 mm long - ..... Steering lock 111 905 851 E/H from Chassis No. 4 010 995 up to 117 999 000	1	M 55: 111-118, 151, 152
105/A 57	*111 905 881 A	Mounting screw 67 mm long - ..... Steering lock 111 905 851 E/H from Chassis No. 4 010 995 up to 117 999 000	1	M 55: 111-118, 151, 152
-	111 905 881 C	Mounting screw 81 mm long - ..... Steering lock 111 905 851 E/H (Only together with 111 415 591) from Chassis No. 4 010 995 up to 117 999 000	1	M 55: 111-118, 151, 152
-	111 905 881 D	Mounting screw 51 mm long - ..... Steering lock 111 905 851 E/H (Only together with 111 415 591) from Chassis No. 4 010 995 up to 117 999 000	1	M 55: 111-118, 151, 152
-	131 905 881	Mounting screw 31 mm long - ..... Steering lock 141 905 851 from Chassis No. 147 000 001 up to 147 999 000	2	M 55: 141-144
-	N 11 652.1	Washer 7 ..... from Chassis No. 147 000 001 up to 147 999 000	2	M 55: 141-144
A 58	113 905 887	Steering lock with buzzer contact without starter switch from Chassis No. 118 000 001 up to 119 1200 000 from Chassis No. 110 2000 001 up to 110 3100 000	1 1	M 55: 111-118, 151, 152
-	N 13 042 2	M 3X5 ..... from Chassis No. 118 000 001	1	
A 59		no longer available		
-	113 919 105	Trigger impulse coil ..... from Chassis No. 112 2109 264	1	M 157: 113, 114, 117, 118, 151, 152

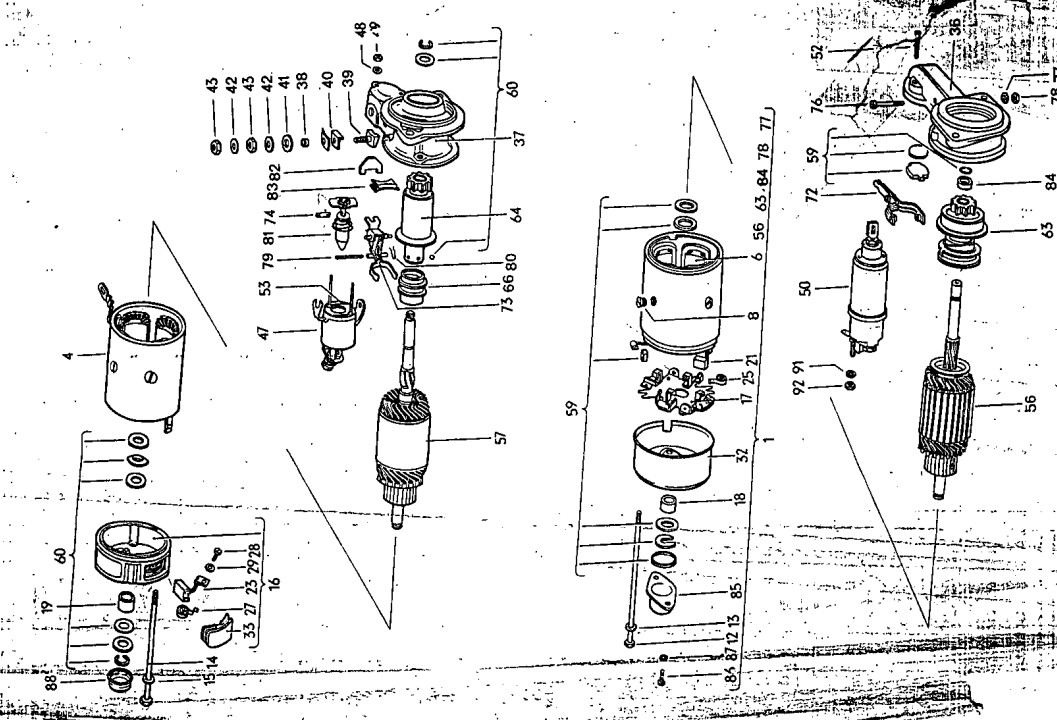
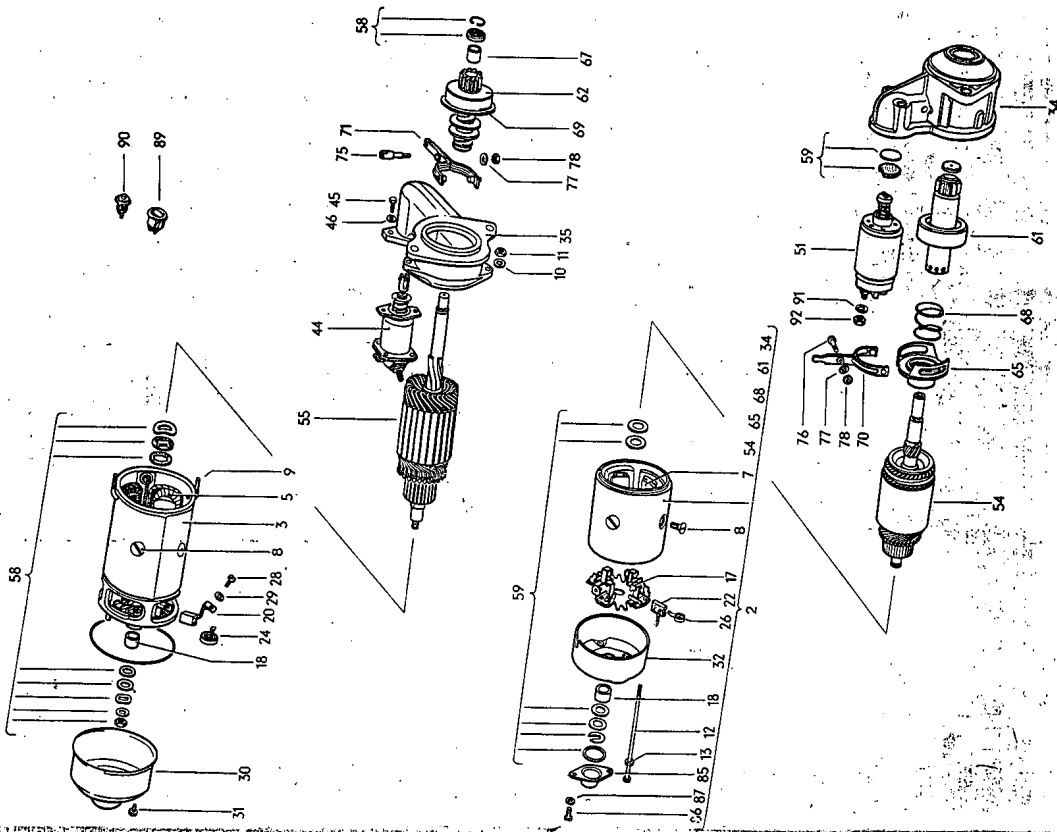

16 E

Top 1-3

9-31

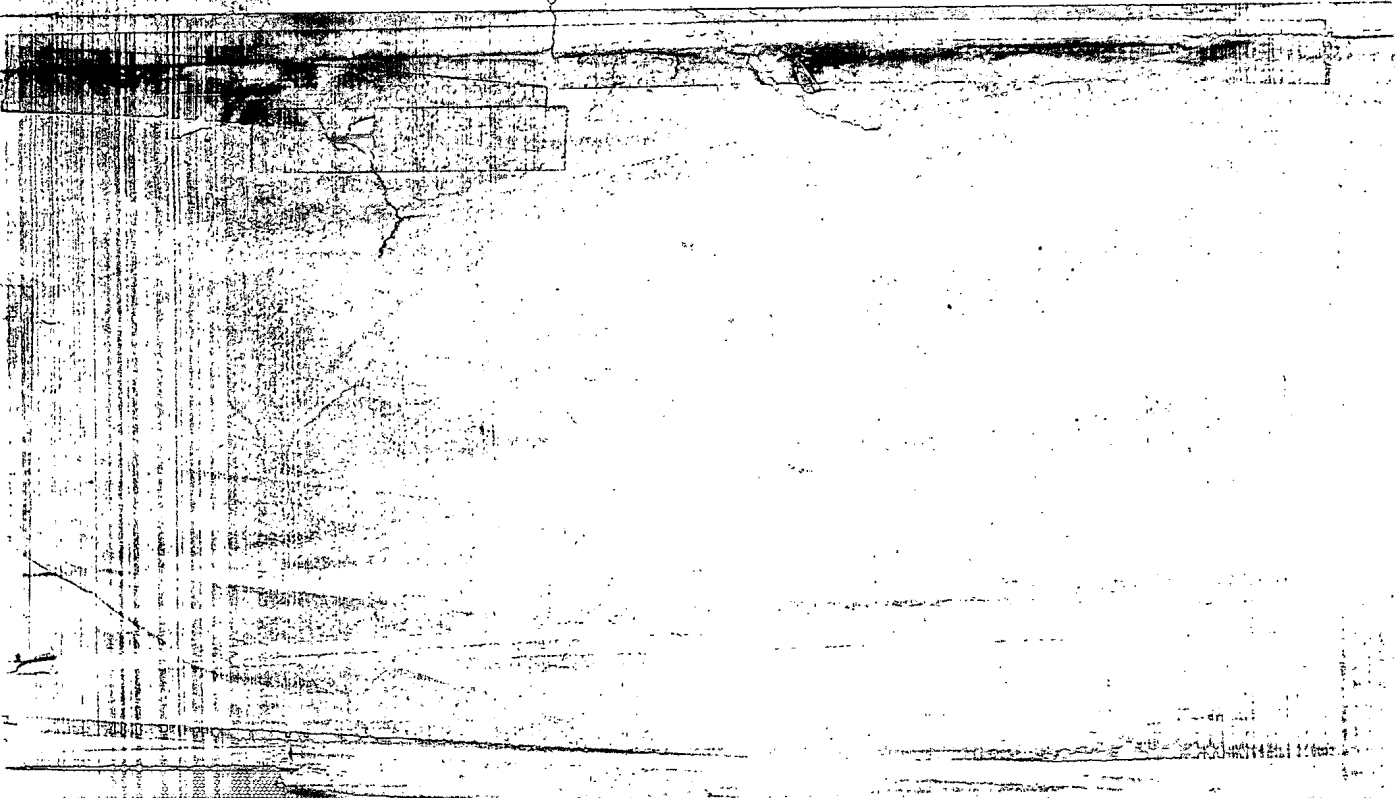

Starting Motor-Versions

No.	Identification	from Chassis No.	to Chassis No.	Model	Part No.
1	111 911 021 Bosch 6 V AL/EED 0,4/6 L 4		1 394 119		113 911 021 B
2	111 911 021 B Bosch 6 V AL/EED 0,5/6 L 34	1 394 120	2 528 667		113 911 021 B
3	111 911 021 C Bosch 6 V AL/EED 0,5/6 L 44	2 528 668	3 192 506		113 911 021 B
4	111 911 021 D VW 6 V	2 528 668	3 192 506		113 911 021 B
5	113 911 021 Bosch 6 V AL/EED 0,5/6 L 49	3 192 507	4 010 994		113 911 021 B
6	113 911 023 Bosch 12 V AL/EEF 0,8/12 L 1		116 1021 300	M 610	113 911 023
7	113 911 021 A VW 6 V	3 192 507	116 1021 300		113 911 021 B
8	113 911 021 B Bosch 6 V AL/EEF 0,5/6 L 1	3 192 507	116 1021 300		113 911 021 B
9	141 911 021 Bosch 6 V	146 350 066	146 1021 300	141-144	111 911 021 E
10	111 911 021 F VW 6 V	117 000 001	117 999 000		111 911 021 E
11	111 911 021 G Bosch 6 V	117 000 001	117 999 000		111 911 021 E
12	111 911 023 Bosch 12 V	117 000 001	117 999 000	M 610: 111-118, 151, 152	311 911 023 D
13	211 911 023 Bosch 12 V AL/EEF 0,7/12 L	117 000 001	117 999 000	M 610: 141-144	311 911 023 D
14	141 911 021 A Bosch 6 V	147 000 001	147 999 000	141-144	111 911 021 E
15	111 911 021 E Bosch 6 V	117 000 001 118 000 001	117 999 000	111, 112, 115, 116	111 911 021 E
16	111 911 023 A VW 12 V	118 000 001	119 1200 000	113, 114, 117, 118, 141-144, 151, 152 M 610: 111, 112, 115, 116	311 911 023 D
17	311 911 023 B Bosch 12 V	118 000 001	119 1200 000	113, 114, 117, 118, 141-144, 151, 152 M 610: 111, 112, 115, 116	311 911 023 D

Typ 1-11

Illustration



No.	Identification	from Chassis No.	to Chassis No.	Model	Part No.	
18	003 911 023 A	Bosch	12 V	M 9	003 911 023 A	
19	003 911 023	Bosch	12 V	M 9	003 911 023 A	
20	311 911 023 C	Bosch	12 V	110 2000 001	113, 114, 117, 118, 141-144, 151, 152 M 610: 111, 112, 115, 116	311 911 023 D
21	311 911 023 D	Bosch	12 V	110 2000 001	113, 114, 117, 118, 141-144, 151, 152 M 610: 111, 112, 115, 116	311 911 023 D

Key No.	Part No.	Description	Quantity	Type and model
<b>STARTING MOTOR</b>				
(1)	111 911 021 E	Starting motor 6 V (Bosch) .....	1	141-144
		from Chassis No. 146 350 066 up to 146 1021 300	1	
		from Chassis No. 117 000 001 up to 117 999 000	1	111, 112, 115, 116
1	113 911 021 B	Starting motor 6 V (Bosch AL/EEF 0.5/6 L 1) .....	1	
		up to Chassis No. 116 350 065	1	111-118, 151, 152;
		from Chassis No. 116 350 066 up to 116 1021 300	1	M 5: 141-144
		from Chassis No. 117 000 001 up to 117 999 000	1	M 5
2	003 911 023 A	Starting motor 12 V (Bosch) .....	1	M 9
(1)	113 911 023	Starting motor 12 V (Bosch AL/EEF 0.8/12 L 1) .....	1	M 610
		up to Chassis No. 116 1021 300		
(1)	311 911 023 D	Starting motor 12 V (Bosch) .....	1	M 610, M 611
		from Chassis No. 117 000 001	1	113, 114, 117, 118,
		from Chassis No. 118 000 001	1	141-144, 151, 152

**STARTING MOTOR PARTS**

(3)	111 911 105	Housing with field coils - Starting motor 1 .....	1	
3	111 911 105 A	Housing with field coils - Starting motor 2, 3, 5 ..	1	
4	211 911 105 A	Housing with field coils - Starting motor 4, 7 .....	1	
(4)	211 911 105 B	Housing with field coils - Starting motor 10 .....	1	
(4)	211 911 105 C	Housing with field coils - Starting motor 16 .....	1	
(5)	111 911 115	Field coil - Starting motor 1 .....	1	
5	111 911 115 A	Field coil - Starting motor 2, 3, 5 .....	1	
6	113 911 115	Field coil - Starting motor 8, 9, 11, 14, 15 .....	1	
(6)	113 911 115 A	Field coil - Starting motor 12, 13, 17 .....	1	

Key No.	Part No.	Description	Quantity	Type and model
7	113 911 115 B	Field coil - Starting motor 6, 8, 19	1	
(7)	311 911 115 A	Field coil - Starting motor 20	1	
(7)	311 911 115 B	Field coil - Starting motor 21	1	
8	N 10 999 1	Screw, countersunk head, AM 10X13.5	4	
9	111 911 145	Hook bolt - Starting motor 1-3, 5	2	
10	N 12 234 1	Spring washer B 7	3	
11	N 11 007 1	Nut, hex. M 7	3	
12	113 911 145 A	Housing bolt - Starting motor 6, 8, 9, 11-15, 17-21	2	
13	N 11 523 3	Washer A 5.3	2	
(12)	211 911 145	Housing bolt M 7 - Starting motor 4, 7, 10	2	
(13)	N 12 234 1	Spring washer B 7	2	
14	211 911 145 A	Housing bolt M 5 - Starting motor 7, 10	2	
(14)	211 911 145 B	Housing bolt M 5 - Starting motor 16	2	
(14)	311 911 145 A	Housing bolt - Starting motor 21	2	
15	N 11 523 3	Washer A 5.3	2	
16	211 911 205	End plate with carbon brushes - Starting motor 4, 7, 10, 16	1	
17	113 911 209 A	Brush holder plate - Starting motor 6, 8, 11, 14, 15, 18, 19	1	
(17)	113 911 209 B	Brush holder plate - Starting motor 12, 13, 17	1	
(17)	311 911 209 A	Brush holder plate - Starting motor 20, 21	1	
18	111 911 213 A	Commutator end bearing brush - Starting motor 1-3, 5, 6, 8, 9, 11-15, 17-21	1	

Key No.	Part No.	Description	Quantity	Type and model
19	211 911 213	End plate brush - Starting motor 4, 7, 10, 16	1	
20	111 911 215 A	Carbon brush - Starting motor 1-3, 5	4	
21	111 911 215 B	Carbon brush - Starting motor 8, 9, 11, 14, 15	4	
22	111 911 215 C	Carbon brush - Starting motor 6, 12, 13, 17-19	4	
23	211 911 215	Carbon brush - Starting motor 4, 7, 10, 16	2	
-	311 911 215	1 set of carbon brushes - Starting motor 20, 21	1	
24	111 911 219	Spring - Brush - Starting motor 1-3, 5	4	
25	113 911 219	Spring - Brush - Starting motor 8	4	
26	113 911 219 A	Spring - Brush - Starting motor 6, 9, 11-15, 17-21	2	
27	211 911 219	Spring - Brush - Starting motor 4, 7, 10, 16	2	
28	N 10 695 1	Screw, cheese head AM 4x6	4	
29	N 12 004 1	Lock washer B 4	4	
-	211 911 231	Insulating plate - Starting motor 7, 10	2	
30	111 911 235	End cap for commutator bearing - Starting motor 1-3, 5	1	
31	N 10 704 2	Screw, cheese head AM 5x10	2	
32	113 911 235	Commutator bearing - Starting motor 6, 8, 9, 11-15, 17-21	1	
33	211 911 235	Sealing cap - Starting motor 4, 7, 10, 16	2	
34	003 911 255	Intermediate bearing - Starting motor 18, 19	1	
(35)	111 911 255	Intermediate bearing - Starting motor 1	1	
35	111 911 255 A	Intermediate bearing - Starting motor 2, 3, 5	1	

Key No.	Part No.	Description	Quantity	Type and model
36	113 911 255 A	Intermediate bearing – Starting motor 6, 8, 11–15, 17	1	
37	211 911 255	Intermediate bearing – Starting motor 4, 7	1	
(37)	211 911 255 A	Intermediate bearing – Starting motor 10	1	
(37)	211 911 255 B	Intermediate bearing – Starting motor 16	1	
(37)	311 911 255 A	Intermediate bearing – Starting motor 20	1	
(37)	311 911 255 B	Intermediate bearing – Starting motor 21	1	
38	211 911 263	Insulation sleeve – Starting motor 4, 7, 10	2	
(38)	211 911 263 A	Insulation sleeve – Starting motor 16	2	
39	211 911 265 B	Terminal – Starting motor 7, 10, 16	2	
40	211 911 267 A	Contact piece – Starting motor 10, 16	2	
41	211 911 271	Insulating disc – Starting motor 4, 7, 10, 16	2	
42	N 12 228 2	Spring washer B 8	4	
43	N 11 008 8	Nut, hex. M 8	4	
44	113 911 285	Solenoid switch – Starting motor 1–3, 5	1	
45	N 10 215 4	Bolt, hex. head M 6×15	2	
46	N 12 006 2	Lock washer B 6	2	
47	113 911 285 A	Switch housing with coil – Starting motor 7, 10	1	-VW
48	N 12 224 1	Spring washer B 4	2	
49	N 11 004 2	Nut, hex. M 4	2	
50	113 911 285 B	Solenoid switch – Starting motor 6 V, 8	1	Bosch
(50)	211 911 285 A	Switch housing with coil – Starting motor 16	1	

Key No.	Part No.	Description	Quantity	Type and model
(50)	311 911 285	Solenoid switch - Starting motor 6 V, 11, 14, 15	1	
51	003 911 287	Solenoid switch - Starting motor 18, 19	1	
(50)	113 911 287 A	Solenoid switch - Starting motor 12 V, 6, 12, 13, 17	1	
(50)	311 911 287	Solenoid switch - Starting motor 20, 21	1	
52	N 10 988 1	Screw, countersunk head AM 6x20	2	
53	211 911 289	Insulating disc - Starting motor 4, 7, 10 16	1	
54	003 911 311	Armature - Starting motor 18, 19	1	
(55)	111 911 311	Armature - Starting motor 1	1	
55	111 911 311 A	Armature - Starting motor 2, 3, 5	1	
56	113 911 311	Armature - Starting motor 8	1	
(56)	113 911 311 B	Armature - Starting motor 12, 13, 17	1	
(56)	113 911 311 C	Armature - Starting motor 9, 11 14, 15	1	
57	211 911 311 A	Armature - Starting motor 4, 7	1	
(57)	211 911 311 B	Armature - Starting motor 10	1	
(57)	211 911 311 C	Armature - Starting motor 16	1	
(57)	311 911 311 A	Armature - Starting motor 20	1	
(57)	311 911 311 B	Armature - Starting motor 21	1	
58	111 911 320	Small parts kit - Starting motor 1-3, 5	1	
59	113 911 320	Small parts kit - Starting motor 6, 8, 9, 11-15, 17-21	1	
60	211 911 320	Small parts kit - Starting motor 4, 7, 10, 16	1	
61	003 911 335	Drive - Starting motor 18, 19	1	



Key No.	Part No.	Description	Quantity	Type and model
62	111 911 335 B	Drive - Starting motor 1-3, 5	1	
63	113 911 335 A	Drive - Starting motor 8	1	
(63)	113 911 335 C	Drive - Starting motor 12, 13, (17)	1	
(63)	113 911 335 D	Drive - Starting motor 9, 11, 14, 15	1	
64	211 911 335 A	Drive - Starting motor 4, 7	1	
(64)	211 911 335 C	Drive - Starting motor 10, (16)	1	
(64)	311 911 335 A	Drive - Starting motor 20, 21	1	
65	003 911 339	Shift bush - Drive - Starting motor 18, 19	1	
66	211 911 339 A	Shift bush - Starting motor 4, 7, 10, 16	1	
67	111 911 341	Bearing bush in pinion drive - Starting motor 1-3, 5	1	
68	003 911 343	Spring between drive and end plate Starting motor 18, 19	1	
-	111 911 343 A	Guide ring, rear, for pinion drive - Starting motor 2	1	
(68)	211 911 343	Spring between drive and end plate Starting motor 10, 16	1	
-	211 911 345	Thrust washer - Spring - Starting motor 10, 16	1	
-	111 911 349	Disc washer - Pinion drive - Starting motor 2, 3, 5	1	
69	111 911 351	Cover plate - Pinion drive - Starting motor 1-3, 5	1	
70	003 911 365	Engaging fork - Starting motor drive - Starting motor 18, 19	1	
71	111 911 365	Engaging fork - Starting motor drive - Starting motor 1-3, 5	1	
2	113 911 365	Engaging fork - Starting motor drive - Starting motor 6, 8, 9, 11-15, 17	1	

Key No.	Part No.	Description	Quantity	Type and model
73	211 911 365	Lever linkage – Starting motor 4, 7, 10 .....	1	
(73)	211 911 365 A	Lever linkage – Starting motor 16 .....	1	
-	311 911 365	Engaging fork – Starting motor drive – Starting motor 20, 21 .....	1	
74	211 911 381	Pivot – Starting motor 4, 7, 10, 16 .....	1	
75	111 911 383	Bolt – Engaging fork – Starting motor 1-3, 5, 18, 19	1	
76	113 911 383	Bolt – Engaging fork – Starting motor 6, 8, 9, 11-15, 17 .....	1	
77	N 12 006 2	Lock washer B 6 .....	1	
78	N 11 006 2	Nut, hex. M 6 .....	1	
79	211 911 383	Mounting bolt – Starting motor 4, 7, 10, 16 .....	2	
-	311 911 383	Bolt – Engaging fork – Starting motor 20, 21 .....	1	
80	N 12 433 1	Spring washer 3.2 .....	2	
81	211 911 405	Solenoid core – Starting motor 4, 7, 10 .....	1	
(81)	211 911 405 A	Solenoid core – Starting motor 16 .....	1	
82	211 911 421	Insulating plate – Starting motor 4, 7, 10, 16 .....	1	
-	111 911 457	Thrust washer – Starting motor 1-3, 5 .....	1	
83	211 911 465	Rubber (seal) profile – Starting motor 4, 7, 10 .....	1	
(83)	211 911 465 A	Rubber (seal) profile – Starting motor 16 .....	1	
-	211 911 467	Support – Rubber seal – Starting motor 16 .....	1	
-	113 911 467	Washer in intermediate bracket – Starting motor 8 .....	1	
-	111 911 471	Spring washer – Starting motor 1-3, 5 .....	1	

Typ 1-3

Illustration 57

Key No.	Part No.	Description	Quantity	Type and model
-	113 911 475	Holding ring - Starting motor 6, 8	1	
84	113 911 479	Stop ring on armature shaft - Starting motor 8	1	
(84)	113 911 479 A	Stop ring on armature shaft - Starting motor 9, 11-15, 17, 20, 21	1	
-	111 911 485	Circlip on armature shaft - Starting motor 1-3, 5	1	
-	113 911 485	Circlip on armature shaft - Starting motor 8	1	
85	113 911 495	Cap - Starting motor 6, 8, 9, 11-15, 17-21	1	
86	N 10 695 1	Screw, cheese head AM 4x6	2	
87	N 12 004 1	Lock washer B 4	2	
88	211 911 495	Cap - Starting motor 4, 7, 0, 16	1	
-	111 911 499	Gasket - Cap - Starting motor 2, 3, 5	1	
89	113 911 509	Push button - Starter, ivory up to Chassis No. 1 - 397 022	1	
90	111 911 511	Push button - Starter from Chassis No. 1 - 397 023 up to 1 - 575 414	1	
91	N 12 008 2	Lock washer B 8	1	
92	N 11 132 2	Nut, hex. M 8	1	



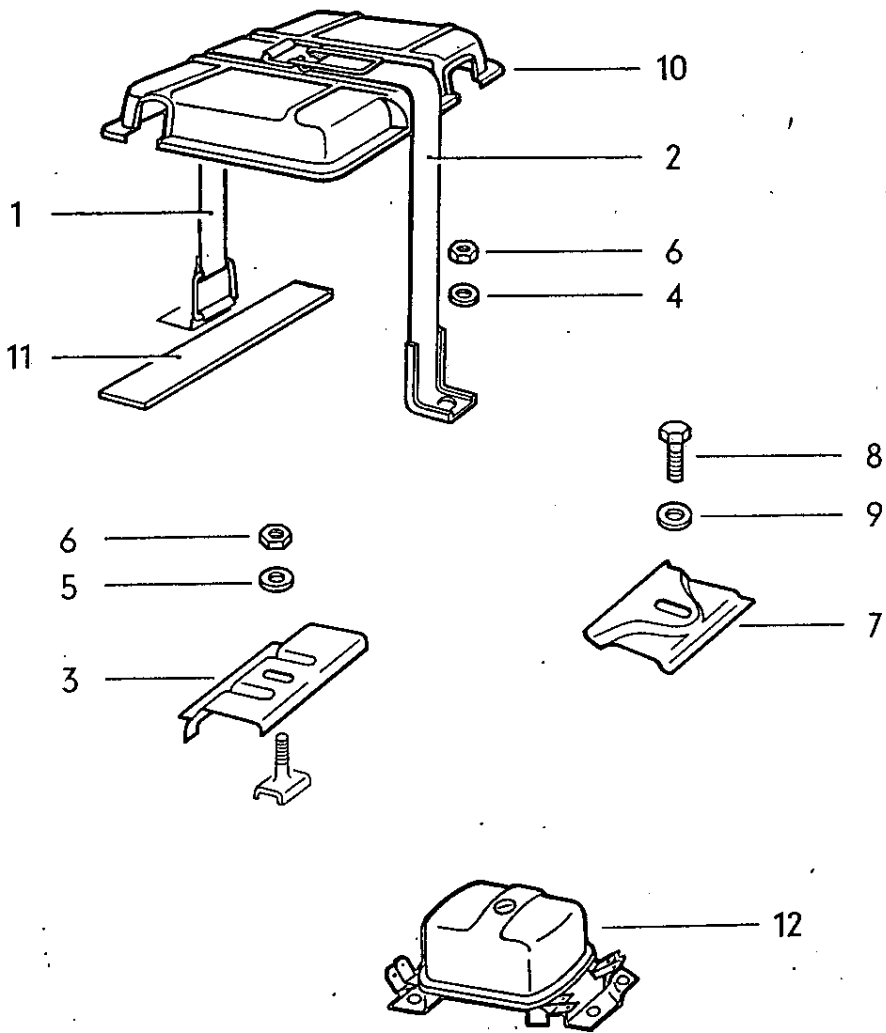

Key No.	Part No.	Description	Quantity	Type and model
<b>BATTERY MOUNTING, BATTERY COVER CIRCUIT BREAKER</b>				
(1)	311 915 303	Mounting strap - Battery .....		
		from Chassis No. 6 317 836 up to 6 502 399	1	113, 114, 117, 118, 151, 152
		from Chassis No. 115 000 001 up to 116 629 734	1	111-118, 151, 152
1	111 915 303	Mounting strap - Battery .....		
		from Chassis No. 116 629 735 up to 116 1021 300	1	111-118, 151, 152
		from Chassis No. 117 000 001 up to 118 160 490	1	111, 112, 115, 116
		from Chassis No. 118 160 491	1	M 67
(1)	111 915 303 A	Mounting strap - Battery .....		
		from Chassis No. 117 000 001 up to 117 999 000	1	M 610
		from Chassis No. 117 000 001 up to 119 102 023	1	M 613
(1)	131 915 303	Mounting strap - Battery .....		
		from Chassis No. 147 000 001 up to 147 999 000	1	141-144
(1)	211 915 305 B	Mounting strap - Battery .....		
		from Chassis No. 1 784 220 up to 146 1021 300	1	141-144
(1)	211 915 305 C	Mounting strap - Battery .....		
		from Chassis No. 147 000 001 up to 147 999 000	1	141-144
(1)	111 915 305	Mounting strap - Battery .....		
		from Chassis No. 1 - 397 023 up to 1 - 575 414	1	111-118, 151, 152
(1)	111 915 305 A	Mounting strap - Battery .....		
		from Chassis No. 1 - 575 415 up to 1 - 929 745	1	111-118, 151, 152
(1)	111 915 305 B	Mounting strap - Battery .....		
		from Chassis No. 1 - 929 746 up to 6 317 835	1	111-118, 151, 152
		from Chassis No. 6 317 836 up to 6 502 399	1	111, 112, 115, 116
		up to Chassis No. 1 784 219	1	141, 143
2	113 915 305	Mounting strap with fastener - Battery .....		
		from Chassis No. 6 317 836 up to 6 502 399	1	113, 114, 117, 118, 151, 152
		from Chassis No. 115 000 001 up to 116 1021 300	1	111-118, 151, 152
		from Chassis No. 117 000 001 up to 118 160 490	1	111, 112, 115, 116
		from Chassis No. 118 160 491	1	M 67
3	111 701 433	Retaining clamp - Plastic battery .....		
		from Chassis No. 117 000 001 up to 118 160 490	1	113, 114, 117, 118, 151, 152
		from Chassis No. 118 160 491	1	
4	N 11 558 1	Washer 8.4 .....		
		up to Chassis No. 116 1021 300	1	
		from Chassis No. 117 000 001 up to 118 160 490	1	111, 112, 115, 116
		from Chassis No. 118 160 491	1	M 67



Key No.	Part No.	Description	Quantity	Type and model
5	311 827 181	Washer 8.3 ..... from Chassis No. 117 000 001 up to 118 160 490 from Chassis No. 118 160 491	1 1	113, 114, 117, 118, 151, 152
6	N 11 008 8	Nut, hex. M 8 ..... from Chassis No. 117 000 001	1	
7	131 915 313	Retaining clip - Battery ..... from Chassis No. 148 000 001	1	141-144
8	N 10 246 1	Bolt, hex. head M 8x45 .....	1	141-144
9	N 11 558 2	Washer 8.4 .....	1	141-144
(7)	111 915 331	Retaining clip - Battery ..... up to Chassis No. 1 - 397 022	2	111-118, 151, 152
-	111 915 333	Spring - Battery cover ..... up to Chassis No. 1 - 397 022	2	111-118, 151, 152
(10)	111 915 405	Cover - Battery 6 V ..... up to Chassis No. 1 - 397 022	1	111-118, 151, 152
(10)	111 915 405 A	Cover - Battery 6 V ..... from Chassis No. 1 - 397 023 up to 1 - 929 745	1	111-118, 151, 152
10	111 915 405 B	Cover - Battery 6 V, 66 Ah ..... from Chassis No. 1 - 929 746 up to 116 1021 300 from Chassis No. 117 000 001 up to 118 160 490 from Chassis No. 147 000 001 up to 147 999 000	1 1 1	111, 112, 115, 116 141-144
(10)	111 915 405 D	Cover - Battery 6 V, 88 Ah .....	1	M 167
(10)	113 915 405	Cover - Battery 12 V, 44 Ah .....	1	M 610, M 611, M 613
(10)	211 915 405	Cover - Battery 6 V, 77 Ah ..... from Chassis No. 1 - 929 746	1	M 67
(10)	131 915 411	Cover - Plastic battery ..... from Chassis No. 117 000 001 up to 117 999 000 from Chassis No. 118 000 001	1 1	113, 114, 117, 118, 151, 152 111, 112, 115, 116
(10)	211 915 411 A	Cover - Plastic battery ..... from Chassis No. 142 2000 001	1	141-144
11	111 915 441	Mat - Battery well ..... up to Chassis No. 116 1021 300 from Chassis No. 117 000 001 up to 118 160 490 from Chassis No. 118 160 491	2 2 2	111, 112, 115, 116 M 67
12	113 915 511 A	Circuit breaker 12 V .....	1	M 613



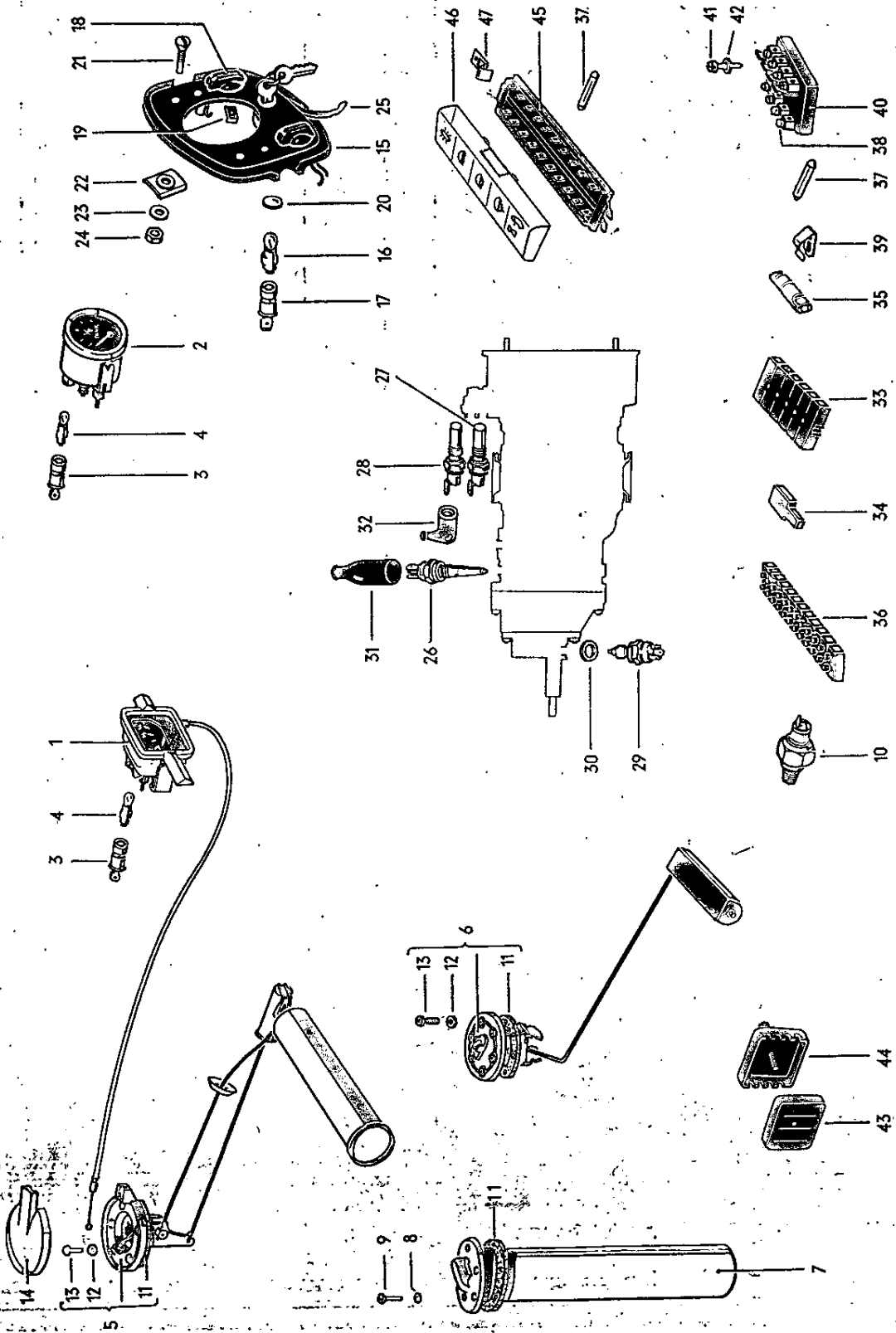

Key No.	Part No.	Description	Quantity	Type and model
25 DIN b.h.p.=30 SAE , 30=36 , 34=41.5 , 37=47 , 40=49/50 , 44=52/53 , 46=55 , 47=57 , 48=58 , 50=60				
<b>INSTRUMENTS</b>				
1	113 919 029	Fuel gauge (mechanical) ..... from Chassis No. 4 010 995 up to 117 999 000	1	113, 117, 151
-	114 919 029	Fuel gauge (RHD) (mechanical) ..... from Chassis No. 4 010 995 up to 117 999 000	1	114, 118, 152
-	111 919 031	Fuel gauge (electrical) ..... up to Chassis No. 1 - 929 745	1	
2	143 919 031 A	Fuel gauge (electrical) ..... from Chassis No. 1 - 929 746 up to 1 600 439	1	
3	111 957 397	Socket - Bulb ..... up to Chassis No. 117 999 000	1	113, 114, 117, 118, 151, 152
4	N 17 722 1	Indicator bulb J 6 V 1.2 W ..... up to Chassis No. 117 999 000	1	113, 114, 117, 118, 151, 152
-	N 17 722 2	Indicator bulb J 12 V 2 W ..... up to Chassis No. 117 999 000	1	M 610
5	113 919 049 C	Fuel gauge, tank unit (mechanical) ..... from Chassis No. 4 010 995 up to 117 999 000	1	113, 114, 117, 118, 151, 152
6	113 919 049 D	Fuel gauge, tank unit (electrical) ..... from Chassis No. 118 000 001 up to 110 3100 000 from Chassis No. 110 2000 001 from Chassis No. 111 2000 001	1 1 1	113, 114, 117, 118, 151, 152 M 40 M 1
7	111 919 051	Fuel gauge, tank unit (electrical) ..... up to Chassis No. 1 - 929 745	1	
-	113 919 051 F	Fuel gauge, tank unit (electrical) ..... from Chassis No. 111 2000 001	1	113, 114, 117, 118, 151, 152
8	N 13 802 1	Gasket A 5X9 ..... up to Chassis No. 1 600 439	5	
9	N 14 131 2	Screw, fillister head AM 5X15 ..... up to Chassis No. 1 600 439	5	
-	111 919 081	Switch - Oil pressure ..... up to Engine No. 1 - 090 761	1	111, 112
10	021 919 081 A	Switch - Oil pressure (0.15 kg/sq.cm) ..... from Chassis No. 1 - 090 762	1	25-, 30-, 34-, 37-, 40-, 44-, 46-, 47-, 48-, 50 b.h.p.



Key No.	Part No.	Description	Quantity	Type and model
25 DIN b.h.p.=30 SAE , 30=36 , 34=41.5 , 37=47 , 40=49/50 , 44=52/53 , 46=55 , 47=57 , 48=58 , 50=60				
11	113 919 133	Gasket - Fuel gauge tank unit up to Chassis No. 110 3100 000 from Chassis No. 111 2000 001	1 1	113, 114, 117, 118, 151, 152 M 1
12	N 13 802 1	Sealing washer A 5×9 - Tank unit mounting screw tank unit from Chassis No. 4 010 995	5	113, 114, 117, 118, 151, 152
-	113 919 131 A	Gasket - Fuel gauge tank unit from Chassis No. 111 2000 001	1	113, 114, 117, 118, 151, 152
13	N 14 130 1	Screw, fillister head AM 5×11 from Chassis No. 4 010 995 up to 110 3100 000 from Chassis No. 111 2000 001	5 5	113, 114, 117, 118, 151, 152 M 1
14	113 919 137	Cover - Tank unit from Chassis No. 4 010 995 up to 117 999 000	1	113, 114, 117, 118, 151, 152
-	311 971 939 A	Cable clip - Cable	x	113, 114, 117, 118, 151, 152
-	141 957 397 A	* Socket - Bulb from Chassis No. 118 000 001 up to 118 1016 100 from Chassis No. 118 000 001 up to 111 3200 000 from Chassis No. 111 2000 001 up to 111 3200 000	1 1 1	M 601, M 602 M 23, M 50 151, 152
-	N 17 751 2	* Bulb JG 12 V 1.2 W from Chassis No. 118 000 001 up to 118 1016 100 from Chassis No. 118 000 001 from Chassis No. 111 2000 001	1 1 1	M 601, M 602 M 23, M 50 151, 152
-	111 919 229	* Escutcheon - Warning lamp from Chassis No. 118 000 001 up to 110 3100 000	1	M 50/M 228, M 603
-	111 919 233 B	* Warning light, red - Dual circuit brake from Chassis No. 118 000 001 up to 111 3200 000 from Chassis No. 118 000 001 up to 111 3200 000 from Chassis No. 111 2000 001 up to 111 3200 000	1 1 1	M 23 M 50, M 601, M 602, M 603 151, 152
-	113 919 233 B	Warning light, red - Dual circuit brake from Chassis No. 112 2000 001	1	M 23
-	111 919 237 A	Parking light - Warning lamp (for Italy only) up to Chassis No. 117 999 000 from Chassis No. 118 000 001	1 1	M 34 M 34: 111, 112, 115, 116
-	N 17 722 1	Bulb J 6 V 1.2 W up to Chassis No. 117 999 000 from Chassis No. 118 000 001	1 1	M 34 M 34: 111, 112, 115, 116
-	N 17 722 2	Bulb J 12 V 2 W	1	M 34/M 610

Key No.	Part No.	Description	Quantity	Type and model
25 DIN b.h.p.=30 SAE , 30=36 , 34=41.5 , 37=47 , 40=49/50 , 44=52/53 , 46=55 , 47=57 , 48=58 , 50=60				
<b>INSTRUMENTS</b>				
1	113 919 029	Fuel gauge (mechanical) ..... from Chassis No. 4 010 995 up to 117 999 000	1	113, 117, 151
-	114 919 029	Fuel gauge (RHD) (mechanical) ..... from Chassis No. 4 010 995 up to 117 999 000	1	114, 118, 152
-	111 919 031	Fuel gauge (electrical) ..... up to Chassis No. 1 - 929 745	1	
2	143 919 031 A	Fuel gauge (electrical) ..... from Chassis No. 1 - 929 746 up to 1 600 439	1	
3	111 957 397	Socket - Bulb ..... up to Chassis No. 117 999 000	1	113, 114, 117, 118, 151, 152
4	N 17 722 1	Indicator bulb J 6 V 1.2 W ..... up to Chassis No. 117 999 000	1	113, 114, 117, 118, 151, 152
-	N 17 722 2	Indicator bulb J 12 V 2 W ..... up to Chassis No. 117 999 000	1	M 610
5	113 919 049 C	Fuel gauge, tank unit (mechanical) ..... from Chassis No. 4 010 995 up to 117 999 000	1	113, 114, 117, 118, 151, 152
6	113 919 049 D	Fuel gauge, tank unit (electrical) ..... from Chassis No. 118 000 001 up to 110 3100 000 from Chassis No. 110 2000 001 from Chassis No. 111 2000 001	1 1 1	113, 114, 117, 118, 151, 152 M 40 M 1
7	111 919 051	Fuel gauge, tank unit (electrical) ..... up to Chassis No. 1 - 929 745	1	
-	113 919 051 F	Fuel gauge, tank unit (electrical) ..... from Chassis No. 111 2000 001	1	113, 114, 117, 118, 151, 152
8	N 13 802 1	Gasket A 5X9 ..... up to Chassis No. 1 600 439	5	
9	N 14 131 2	Screw, fillister head AM 5X15 ..... up to Chassis No. 1 600 439	5	
-	111 919 081	Switch - Oil pressure ..... up to Engine No. 1 - 090 761	1	111, 112
10	021 919 081	Switch - Oil pressure (0.15 kg/sq. cm) ..... from Engine No. 1 - 090 762	1	25-, 30-, 34-, 40-, 44-, 47 b.h.p.

Key No.	Part No.	Description	Quantity	Type and model
25 DIN b.h.p.=30 SAE , 30=36 , 34=41.5 , 37=47 , 40=49/50 , 44=52/53 , 46=55 , 47=57 , 48=58 , 50=60				
-	021 919 081 A	Switch - Oil pressure (0.15 kg/sq.cm) ..... from Engine No. AD 0 000 001	1	50 b.h.p.
11	113 919 133	Gasket - Fuel gauge tank unit ..... up to Chassis No. 110 3100 000 from Chassis No. 111 2000 001	1 1	113, 114, 117, 118, 151, 152 M 1
12	N 13 802 1	Sealing washer A 5X9 - ..... Tank unit mounting screw tank unit from Chassis No. 4 010 995	5	113, 114, 117, 118, 151, 152
-	113 919 131 A	Gasket - Fuel gauge tank unit ..... from Chassis No. 111 2000 001	1	113, 114, 117, 118, 151, 152
13	N 14 130 1	Screw, fillister head AM 5X11 ..... from Chassis No. 4 010 955 up to 110 3100 000 from Chassis No. 111 2000 001	5 5	113, 114, 117, 118, 151, 152 M 1
14	113 919 137	Cover - Tank unit ..... from Chassis No. 4 010 995 up to 117 999 000	1	113, 114, 117, 118, 151, 152
-	311 971 939 A	Cable clip - Cable .....	x	113, 114, 117, 118, 151, 152
-	141 957 397 A *	Socket - Bulb ..... from Chassis No. 118 000 001 up to 118 1016 100 from Chassis No. 118 000 001 from Chassis No. 111 2000 001	1 1 1	M 601, M 602 M 23, M 50 151, 152
-	N 17 751 2 *	Bulb JG 12 V 1.2 W ..... from Chassis No. 118 000 001 up to 118 1016 100 from Chassis No. 118 000 001 from Chassis No. 111 2000 001	1 1 1	M 601, M 602 M 23, M 50 151, 152
-	111 919 229 *	Escutcheon - Warning lamp ..... from Chassis No. 118 000 001 up to 110 3100 000	1	M 50/M 228, M 603
-	111 919 233 B *	Warning light, red - Dual circuit brake ..... from Chassis No. 118 000 001 up to 111 3200 000 from Chassis No. 118 000 001 from Chassis No. 111 2000 001	1 1 1	M 23 M 50, M 601, M 602, M 603 151, 152
-	113 919 233 B	Warning light, red - Dual circuit brake ..... from Chassis No. 112 2000 001	1	M 23
-	411 919 237 A	Parking light - Warning lamp (for Italy only) ..... up to Chassis No. 117 999 000 from Chassis No. 118 000 001	1 1	M 34 M 34: 111, 112, 115, 116
-	N 17 722 1	Bulb J 6 V 1.2 W ..... up to Chassis No. 117 999 000 from Chassis No. 118 000 001	1 1	M 34 M 34: 111, 112, 115, 116
-	N 17 722 2	Bulb J 12 V 2 W .....	1	M 34/M 610

Key No.	Part No.	Description	Quantity	Type and model
<b>INSTRUMENT PANEL</b> up to Chassis No. 1 - 397 022				
-	111 925 051	Insert, left - Instrument panel (black) .....	1	111, 112, 115, 116
15	113 925 051	Insert, left - Instrument panel (ivory) .....	1	113, 114, 117, 118, 151, 152
-	113 925 052	Insert, right - Instrument panel (ivory) .....	1	113, 114, 117, 118, 151, 152
-	111 925 102	Insert, right - Instrument panel (black) .....	1	111, 112, 115, 116
16	N 17 721 1	Indicator bulb J 6 V 0.6 W .....	4	
17	111 957 397	Socket - Indicator bulb .....	4	
18	113 925 079	Switch (ivory) - Light and windshield wiper .....	2	
19	113 925 161	Bracket - Speedometer mounting .....	2 4	111, 112, 115, 116 113, 114, 117, 118, 151, 152
20	111 925 231	Warning light lens, green - Instrument panel .....	1	
-	111 925 235	Warning light lens, blue - Instrument panel .....	1	
21	111 925 271	Screw - Instrument panel insert .....	4	
22	111 925 275	Bracket - Instrument panel insert .....	4	
23	N 11 651 1	Washer, 5.8 .....	4	
24	N 11 005 2	Nut, hex. M 5 .....	4	
25	111 925 301	Sealing strip - Instrument panel insert .....	2	

Key No.	Part No.	Description	Quantity	Type and model
<b>CONTROL SWITCH FOR AUTOMATIC</b>				M 9
26	113 927 205	Control switch – Oil temperature .....	1	
27	113 927 215	Temperature switch 125° C .....	1	
28	113 927 217	Temperature switch 140° C .....	1	
29	113 927 225	Neutral safety switch .....	1	
30	113 927 225A N 13 814 2	Sealing ring A 14×18×1.5 .....	4	
-	113 927 235	Connector (3 points) .....	2	
-	113 927 235 A	Connector (3 points) – Brake light switch .....	2	M 23, M 50 113 945 515 D
-	113 927 237	Connector (2 points) .....	1	
31	411 941 539	Cap – Oil temperature switch .....	1	
-	113 927 247	Cap – Neutral safety switch .....	1	
32	113 927 249	Cap – Temperature switch .....	2	
<b>FUSE BOX</b>				
-	111 937 011	Fuse box (3 fuses) .....	1	111-118, 151, 152 up to Chassis No. 1 – 575 414
-	N 10 702 1	Screw, cheese head AM 5×15 .....	2	
-	111 937 031	Fuse box (6 fuses) .....	1	111-118, 151, 152 up to Chassis No. 1 – 575 414
-	N 10 702 1	Screw, cheese head AM 5×15 .....	2	
-	N 12 225 1	Spring washer B 5 .....	2	
-	N 11 005 2	Nut, hex. M 5 .....	2	

Key No.	Part No.	Description	Quantity	Type and model
-	111 937 037	Fuse box (8 fuses) ..... from Chassis No. 3 192 507 up to 116 1021 300	1	
-	111 937 041	Fuse box (2 fuses) ..... from Chassis No. 1 - 575 415 up to 2 528 667	1	
-	N 11 389 1	Tapping screw, cheese head B 4.8×13 .....	2	
33	111 937 077 E	Cable connector (6 points) ..... up to Chassis No. 118 613 744	x	
34	*111 937 078	Cable divider .....	1	
-	111 971 977	Flat terminal insulator, single ..... from Chassis No. 118 613 745	x	
-	111 937 091 A	Connector with fuse 8 ..... from Chassis No. 118 963 240	x	
35	*111 937 093 A	Connector with fuse ..... up to Chassis No. 118 963 239	1	111-118, 151, 152; M 47
-	111 937 095 A	Set screw - Connector .....	2	
36	N 17 471 0	Connector .....	4	111-118, 151, 152
37	N 17 121 1	Fuse 8 ..... up to Chassis No. 116 1021 300 from Chassis No. 117 000 001	6 10	
-	N 17 121 4	Fuse 16 (red) ..... up to Chassis No. 116 1021 300	2	
38	111 937 135	Set screw - Fuse box ..... up to Chassis No. 3 192 506	x	
-	111 937 155	Cover - Fuse box (6 fuses) ..... up to Chassis No. 1 - 575 414	1	111-118, 151, 152
39	*111 937 197	Clip - Connector - Back-up lamp ..... from Chassis No. 117 000 001 up to 110 3100 000 from Chassis No. 111 2000 001 up to 111 3200 000	2 1	M 22, M 47 151, 152; M 22, M 23 M 47, M 616
-	311 963 181 B	Clip ..... from Chassis No. 112 2000 001	1	151, 152; M 22, M 23 M 47, M 616
-	113 937 197	* Clip .....	1	M 60
40	111 937 205	Fuse box (4 fuses) without cover ..... from Chassis No. 1 - 397 023 up to 3 192 506	1	



Key No.	Part No.	Description	Quantity	Type and model
41	N 13 958 3	Tapping screw, countersunk raised head B 3.5×13	1	
42	N 11 521 1	Washer A 3.7	1	
43	111 937 207	Fuse box (4 fuses) without cover from Chassis No. 2 528 668 up to 3 192 506	1	
-	N 11 389 1	Tapping screw, cheese head B 4.8×13	2	
44	111 937 255	Cover - Fuse box (4 fuses) from Chassis No. 1 - 397 023 up to 1 - 575 414 and from Chassis No. 2 528 668 up to 3 192 506	1	
-	111 937 355	Cover - Fuse box (3 fuses) up to Chassis No. 1 - 575 414	1	111-118, 151, 152
-	111 937 455	Cover - Fuse box (2 fuses) from Chassis No. 1 - 575 415 up to 2 528 667	1	
45	111 937 505 F	Fuse box (10 fuses) without cover from Chassis No. 117 000 001 up to 110 3100 000 from Chassis No. 111 2000 001 up to 111 2799 842	1 1	111, 112, 115, 116; M 1
-	111 937 505 G	Fuse box (12 fuses) without cover from Chassis No. 111 2000 001 up to 111 3200 000 from Chassis No. 111 2799 843 up to 111 3200 000	1 1	113, 114, 117, 118, 151, 152 111, 112, 115, 116; M 1
-	111 937 505 H *	Fuse box (12 fuses) without cover from Chassis No. 111 2000 001 up to 111 3200 000	1	M 22
-	111 937 505 L	Fuse box (12 fuses) without cover from Chassis No. 112 2000 001	1	111-118, 151, 152; M 1
-	111 937 505 N	Fuse box (12 fuses) without cover from Chassis No. 112 2000 001	1	M 22
-	111 937 555	Cover - Fuse box (8 fuses) up to Chassis No. 116 1021 300	1	
46	111 937 555 A	Cover - Fuse box (10 fuses) from Chassis No. 118 000 001 up to 110 3100 000 from Chassis No. 111 2000 001 up to 111 2799 842	1 1	111, 112, 115, 116; M 1
-	111 937 555 B	Cover - Fuse box (12 fuses) from Chassis No. 111 2000 001 from Chassis No. 111 2799 843	1 1	113, 114, 117, 118, 151, 152 111, 112, 115, 116; M 1
47	111 937 591	Clip - Fuse box from Chassis No. 3 192 507 up to 110 3100 000 from Chassis No. 111 2000 001	1 1	111, 112, 115, 116; M 1
-	N 15 450 1	Speed nut B 3.9×9.1 from Chassis No. 111 2000 001 from Chassis No. 111 2799 843	2 1	113, 114, 117, 118, 151, 152 111, 112, 115, 116; M 1
-	N 13 961 2	Tapping screw, csk. raised hd. B 3.9×13 from Chassis No. 111 2000 001 from Chassis No. 111 2799 843	2 1	113, 114, 117, 118, 151, 152 111, 112, 115, 116; M 1



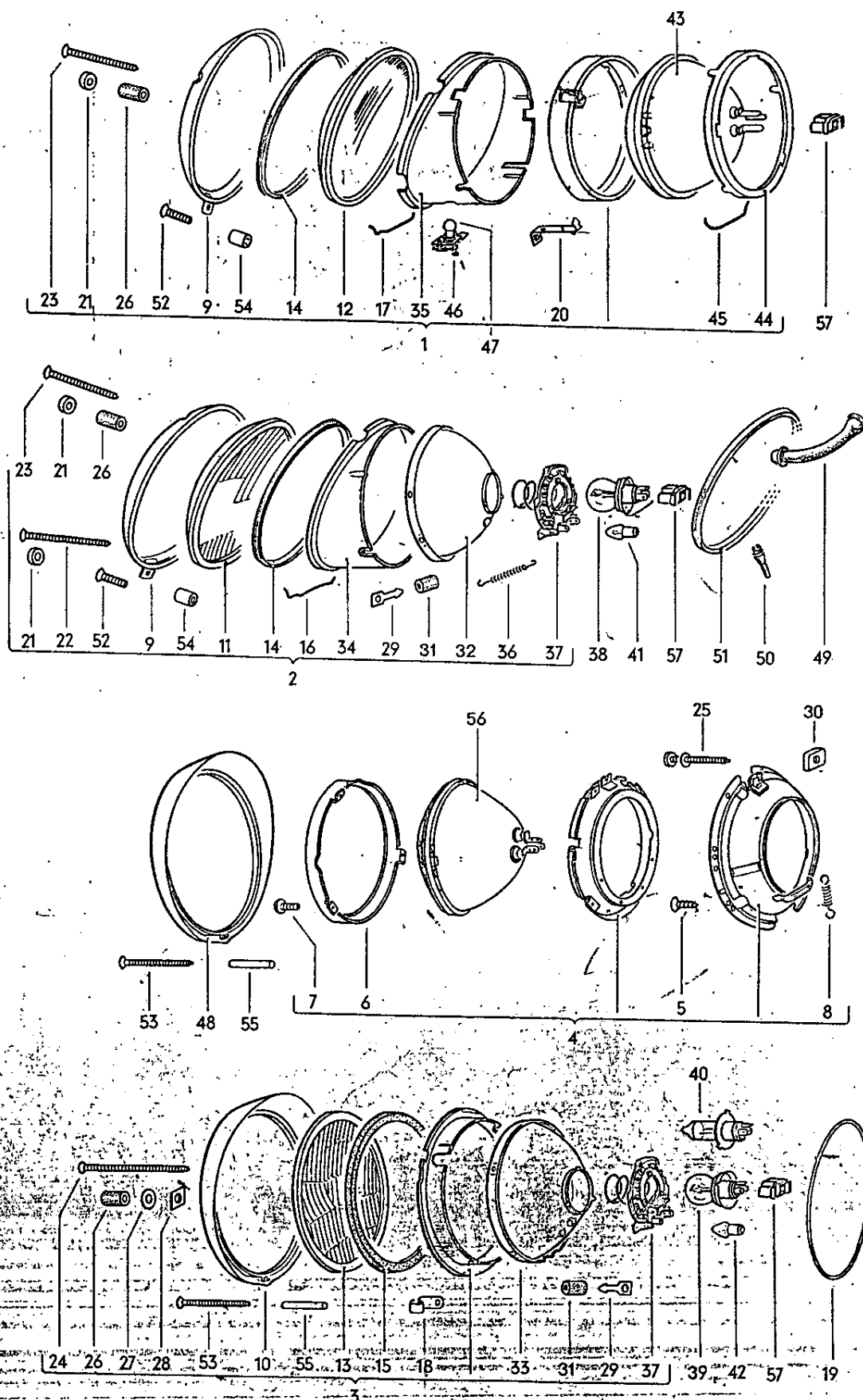

Key No.	Part No.	Description	Quantity	Type and model
<b>HEADLAMP</b>				
(2)	111 941 021 A	Headlamp (Bosch) ..... up to Chassis No. 3 192 506	2	
(2)	111 941 021 B	Headlamp (Hella) ..... up to Chassis No. 3 192 506	2	
1	111 941 037 C *	Headlamp (Sealed-Beam) ..... up to Chassis No. 117 999 000	2	M 22
2	111 941 039	Headlamp, asymmetrical (Hella) ..... (right-hand traffic only) up to Chassis No. 117 999 000	2	
(2)	111 941 039 A	Headlamp, asymmetrical (Bosch) ..... (right-hand traffic only) up to Chassis No. 117 999 000	2	
(2)	112 941 039	Headlamp, asymmetrical (Hella) ..... (left-hand traffic only) up to Chassis No. 117 999 000	2	M 187
(2)	112 941 039 A	Headlamp, asymmetrical (Bosch) ..... (left-hand traffic only) up to Chassis No. 117 999 000	2	M 187
(3)	311 941 039 E	Headlamp, asymmetrical (Bosch) ..... (right-hand traffic only) from Chassis No. 118 000 001	2	
3	311 941 039 F	Headlamp, asymmetrical (Hella) ..... (right-hand traffic only) from Chassis No. 118 000 001	2	
(3)	312 941 039 D	Headlamp, asymmetrical (Hella) ..... (left-hand traffic only) from Chassis No. 118 000 001	2	M 187
(3)	312 941 039 E	Headlamp, asymmetrical (Bosch) ..... (left-hand traffic only) from Chassis No. 118 431 604	2	M 187
(3)	113 941 753	Halogen headlamp (Hella) ..... (right-hand traffic only) from Chassis No. November 1971	2	M 551; 413; 114; 117; 118; 151; 152



Key No.	Part No.	Description	Quantity	Type and model
(3)	113 941 753 A	Halogen headlamp (Bosch) ..... (right-hand traffic only) from Chassis No. November 1971	2	M 551: 113, 114, 117; 118, 151, 152
(3)	114 941 753	Halogen headlamp (Hella) ..... (left-hand traffic only) from Chassis No. November 1971	2	M 187/M 551: 113, 114, 117, 118, 151, 152
(3)	114 971 753 A	Halogen headlamp (Bosch) ..... (left-hand traffic only) from Chassis No. November 1971	2	M 187/M 551: 113, 114, 117, 118, 151, 152
-	000 052 151	Conversion kit for Halogen headlamps (Hella) ... (right-hand traffic only)	1	
-	000 052 152	Conversion kit for Halogen headlamps (Hella) ... (left-hand traffic only)	1	
4	141 941 041	* Retaining ring (Sealed-Beam) ..... from Chassis No. 117 000 001 up to 117 999 000 from Chassis No. 118 000 001	2 2	M 611 M 22, M 23
5	N 13 961 2	* Tapping screw, fillister head B 3.9×13 - ..... Retainer ring from Chassis No. 117 000 001 up to 117 999 000 from Chassis No. 118 000 001	12 12	M 611 M 22, M 23
6	311 941 049	* Retainer - Sealed Beam Unit ..... up to Chassis No. 117 999 000 from Chassis No. 118 000 001	2 2	M 611 M 22, M 23
7	341 941 183	* Tapping screw, fillister head M 4×8 - ..... Retainer ring from Chassis No. 117 000 001 up to 117 999 000 from Chassis No. 118 000 001	6 6	M 611 M 22, M 23
8	113 255 271	* Spring - Retainer ring ..... from Chassis No. 117 000 001 up to 117 999 000 from Chassis No. 118 000 001	2 2	M 611 M 22, M 23
(9)	111 941 111	* Rim - Headlamp (Hella) ..... up to Chassis No. 3 192 506 up to Chassis No. 5 943 201	2 2	M 22
(9)	111 941 111 A	Rim - Headlamp (Bosch) ..... up to Chassis No. 3 192 506	2	

Key No.	Part No.	Description	Quantity	Type and model
9	111 941 111 B *	Rim - Headlamp, asymmetrical (Hella) ..... from Chassis No. 3 192 507 up to 117 999 000	2	
		Rim - Headlamp (Sealed-Beam) (Hella) ..... from Chassis No. 5 943 202 up to 117 999 000	2	M 22
(9)	111 941 111 C	Rim - Headlamp, asymmetrical (Bosch) ..... from Chassis No. 3 192 507 up to 117 999 000	2	
10	311 941 111 A	Rim - Headlamp, asymmetrical ..... from Chassis No. 118 000 001	2	
(11)	111 941 115	Lens - Headlamp (Hella) ..... up to Chassis No. 3 192 506	2	
(11)	111 941 115 A	Lens - Headlamp (Bosch) ..... up to Chassis No. 3 192 506	2	
11	111 941 115 F	Lens - Headlamp, asymmetrical (Hella) ..... (right-hand traffic only) up to Chassis No. 117 999 000	2	
(11)	111 941 115 G	Lens - Headlamp, asymmetrical (Bosch) ..... (right-hand traffic only) up to Chassis No. 117 999 000	2	
12	111 941 115 H *	Lens - Headlamp, plain (Sealed-Beam) ..... up to Chassis No. 117 999 000	2	M 22
(11)	112 941 115	Lens - Headlamp, asymmetrical (Hella) ..... (left-hand traffic only) up to Chassis No. 117 999 000	2	M 187
(11)	112 941 115 A	Lens - Headlamp, asymmetrical (Bosch) ..... (left-hand traffic only) up to Chassis No. 117 999 000	2	M 187
(13)	113 941 115	Headlamp lens for halogen headlamps ..... (Hella, right-hand traffic only) from Chassis No. November 1971	2	M 551, 113, 114, 117, 118, 151, 152



Key No.	Part No.	Description	Quantity	Type and model
(13)	113 941 115 A	Headlamp lens for halogen headlamps ..... (Bosch, right-hand traffic only) from Chassis No. November 1971	2	M 551: 113, 114, 117, 118, 151, 152
(13)	114 941 115	Headlamp lens for halogen headlamps ..... (Hella, left-hand traffic only) from Chassis No. November 1971	2	M 187/M 551: 113, 114, 117, 118, 151, 152
(13)	114 941 115 A	Headlamp lens for halogen headlamps ..... (Bosch, left-hand traffic only) from Chassis No. November 1971	2	M 187/M 551: 113, 114, 117, 118, 151, 152
13	311 941 115 B	Lens - Headlamp, asymmetrical ..... (Hella, right-hand traffic only) from Chassis No. 118 000 001	2	
(13)	311 941 115 C	Lens - Headlamp, asymmetrical ..... (Bosch, right-hand traffic only) from Chassis No. 118 000 001	2	
(13)	312 941 115 B	Lens - Headlamp, asymmetrical ..... (Hella, left-hand traffic only) from Chassis No. 118 000 001	2	M 187
(13)	312 941 115 C	Lens - Headlamp, asymmetrical ..... (Bosch, left-hand traffic only) from Chassis No. 118 2000 001	2	M 187
14	111 941 119	Sealing ring - Headlamp lens ..... up to Chassis No. 117 999 000	2	
15	311 941 119	Sealing ring - Headlamp lens ..... from Chassis No. 118 000 001	2	
16	111 941 125 B	* Retainer spring - Headlamp lens ..... up to Chassis No. 5 943 201 up to Chassis No. 117 999 000	14 14	M 22
17	111 941 125 C	* Retainer spring - Headlamp lens (Sealed-Beam) .. from Chassis No. 5 943 202 up to 117 999 000	14	M 22
18	311 941 125 A	Retainer spring - Headlamp lens ..... from Chassis No. 118 000 001	8	
19	111 941 129	Gasket between headlamp and fender ..... from Chassis No. 117 000 001 up to 117 999 000 from Chassis No. 118 000 001	2 2	M 611

Key No.	Part No.	Description	Quantity	Type and model
-	111 941 135	Spring clip - Headlamp (Hella) ..... up to Chassis No. 3 192 506	2	
20	111 941 137	Adjusting hook - Headlamp (Hella) ..... up to Chassis No. 3 192 506	4	
(20)	111 941 137 A	Adjusting hook - Headlamp, asymmetrical (Hella) ..... up to Chassis No. 117 999 000	2	
21	111 941 139	Gasket - Adjusting screw ..... up to Chassis No. 117 999 000	4	
(22)	111 941 141	Adjusting screw length: 109 mm - 4 <sup>9</sup> / <sub>32</sub> in. (Hella) ..... up to Chassis No. 6 502 399	4	
(23)	111 941 141 A	Adjusting screw length: 55 mm - 2 <sup>5</sup> / <sub>32</sub> in. (Bosch) ..... up to Chassis No. 117 999 000	4	
22	111 941 141 D	Adjusting screw length: 110 mm - 4 <sup>11</sup> / <sub>32</sub> in. .... up to Chassis No. 117 999 000	2	
23	211 941 141	Adjusting screw length: 65 mm - 2 <sup>9</sup> / <sub>16</sub> in. .... up to Chassis No. 117 999 000	2	
24	311 941 141	Adjusting screw length: 69 mm - 2 <sup>23</sup> / <sub>32</sub> in. .... from Chassis No. 118 000 001	4	
25	311 941 141 A *	Adjusting screw length: 40 mm - 1 <sup>9</sup> / <sub>16</sub> in. .... from Chassis No. 117 000 001 up to 117 999 000 from Chassis No. 118 000 001	4 4	M 611 M 22, M 23
-	111 941 143	Spring length: 45 mm - 1 <sup>25</sup> / <sub>32</sub> in. .... Adjusting screw 111 941 141 up to Chassis No. 6 502 399	4	
-	111 941 143 A	Spring length: 50 mm - 1 <sup>31</sup> / <sub>32</sub> in. .... Adjusting screw 111 941 141 A up to Chassis No. 117 999 000	4	
-	111 941 143 B	Spring length: 105 mm - 4 <sup>1</sup> / <sub>8</sub> in. .... Adjusting screw 111 941 141 B up to Chassis No. 6 502 399	4	
26	111 941 143 D	Bush, rubber - Adjusting screw	4	
27	N 11 555 1	Washer 4.3	4	



Key No.	Part No.	Description	Quantity	Type and model
28	N 11 004 2	Nut, hex. M 4 ..... from Chassis No. 115 000 001	8	
-	111 941 145	Nut M 4 - Adjusting screw ..... up to Chassis No. 6 502 399	1	
-	111 941 145 A	Nut M 3 - Adjusting screw ..... up to Chassis No. 6 502 399	4	
-	N 12 507 1	Collet pin 1.5x15 ..... up to Chassis No. 6 502 399	4	
29	111 941 145 B	Adjusting nut - Headlamp, asymmetrical .....	2	
30	311 941 145	* Threaded piece M 5 - Adjusting screw ..... from Chassis No. 117 000 001 up to 117 999 000 from Chassis No. 118 000 001	4 4	M 611 M 22, M 23
31	111 941 147	Rubber mounting - Headlamp reflector .....	6	
(32)	111 941 151 A	Reflector - Headlamp (Bosch) ..... up to Chassis No. 3 192 506	2	
(32)	111 941 151 B	Reflector - Headlamp (Hella) ..... up to Chassis No. 3 192 506	2	
32	111 941 151 C	Reflector - Headlamp, asymmetrical (Hella) ..... (right-hand traffic only) up to Chassis No. 117 999 000	2	
(32)	111 941 151 E	Reflector - Headlamp, asymmetrical (Bosch) ..... (right-hand traffic only) up to Chassis No. 117 999 000	2	
(32)	112 941 151	Reflector - Headlamp, asymmetrical (Hella) ..... (left-hand traffic only) up to Chassis No. 117 999 000	2	M 187
(32)	112 941 151 A	Reflector - Headlamp, asymmetrical (Bosch) ..... (left-hand traffic only) up to Chassis No. 117 999 000	2	M 187
(33)	113 941 151	Reflector for halogen headlamps ..... (Hella, right-hand traffic only) from Chassis No. November 4971	2	M 551: 113, 114, 117, 118, 151, 152

Key No.	Part No.	Description	Quantity	Type and model
(33)	113 941 151 A	Reflector for halogen headlamps (Bosch, right-hand traffic only) from Chassis No. November 1971	2	M 551: 113, 114, 117, 118, 151, 152
(33)	114 941 151	Reflector for halogen headlamps (Hella, left-hand traffic only) from Chassis No. November 1971	2	M 187/M 551: 113, 114, 117, 118, 151, 152
(33)	114 941 151 A	Reflector for halogen headlamps (Bosch, left-hand traffic only) from Chassis No. November 1971	2	M 187/M 551: 113, 114, 117, 118, 151, 152
33	311 941 151 B	Reflector - Headlamp, asymmetrical (Hella, right-hand traffic only) from Chassis No. 118 000 001	2	
(33)	311 941 151 C	Reflector - Headlamp, asymmetrical (Bosch, right-hand traffic only) from Chassis No. 118 000 001	2	
(33)	312 941 151	Reflector - Headlamp, asymmetrical (Hella, left-hand traffic only) from Chassis No. 118 000 001 up to 119 1200 000	2	M 187
(33)	312 941 151 B	Reflector - Headlamp, asymmetrical (Hella, left-hand traffic only) from Chassis No. 110 2000 001	2	M 187
(33)	312 941 151 C	Reflector - Headlamp, asymmetrical (Bosch, left-hand traffic only) from Chassis No. 118 2000 001	2	M 187
(34)	111 941 153 A	Retainer - Headlamp reflector 111 941 151 A up to Chassis No. 3 192 506	2	
34	111 941 153 B	Retainer - Headlamp reflector 111 941 151 B up to Chassis No. 3 192 506	2	
(35)	111 941 153 C *	Retainer - Sealed Beam Unit up to Chassis No. 5 943 201	2	M 22
35	111 941 153 D *	Retainer - Sealed Beam Unit from Chassis No. 5 943 202 up to 117 999 000	2	M 22
36	111 941 157	Spring - Bulb socket (Hella) up to Chassis No. 3 192 506	2	



Key No.	Part No.	Description	Quantity	Type and model
-	111 941 157 A	Mounting bracket for bulb socket (Bosch) ..... up to Chassis No. 3 192 506	2	
(37)	111 941 159 A	Bulb socket - Headlamp (Bosch) ..... up to Chassis No. 3 192 506	2	
(37)	111 941 159 B	Bulb socket - Headlamp (Hella) ..... up to Chassis No. 3 192 506	2	
(38)	N 17 701 1	Bulb B 6 V 35/35 W - Headlamp (Germany) ..... up to Chassis No. 6 502 399	2	
(38)	N 17 701 1Z	Bulb B 6 V 35/35 W (Export) ..... up to Chassis No. 6 502 399	2	
(40)	N 17 720 1	Bulb H 6 V 2 W - Parking light ..... up to Chassis No. 6 502 399	2	
(37)	111 941 159 C	Bulb socket - Headlamp (for France only) ..... up to Chassis No. 3 192 506	2	M 124
37	131 941 159 A	Cap - Headlamp ..... from Chassis No. 3 192 507	2	
38	N 17 705 1	Bulb A 6 V 45/40 W - ..... Headlamp, asymmetrical (Germany) up to Chassis No. 117 999 000 from Chassis No. 118 000 001	2 2	111, 112, 115, 116
(38)	N 17 705 1Z	Bulb A 6 V 45/40 W - ..... Headlamp, asymmetrical (Export) up to Chassis No. 117 999 000 from Chassis No. 118 000 001	2 2	111, 112, 115, 116
(38)	N 17 705 2	Headlamp bulb A 6 V:45/40 W ..... (yellow glass) (asymmetrical) (for France only) (Germany) up to Chassis No. 117 999 000 from Chassis No. 118 000 001	2 2	M 124 M 124: 111, 112, 115, 116
(38)	N 17 705 2Z	Bulb A 6 V 45/40 W (yellow glass) - ..... Headlamp, asymmetrical (for France only) (Export) up to Chassis No. 117 999 000 from Chassis No. 118 000 001	2 2	M 124 M 124: 111, 112, 115, 116

Key No.	Part No.	Description	Quantity	Type and model
39	N 17 705 3	Bulb A 12 V 45/40 W – Headlamp, asymmetrical (Germany) from Chassis No. 118 000 001	2 2	M 610 113, 114, 117, 118, 151, 152
(39)	N 17 705 3Z	Bulb A 12 V 45/40 W – Headlamp asymmetrical (Export) from Chassis No. 118 000 001	2 2	M 610 113, 114, 117, 118, 151, 152
(39)	N 17 705 4	Headlamp bulb A 12 V 45/40 W (yellow glass) (asymmetrical) (Germany) from Chassis No. 118 000 001	2 2	M 124/M 610 M 124: 113, 114, 117, 118, 151, 152
(39)	N 17 705 4Z	Bulb A 12 V 45/40 W (yellow glass) – Headlamp, asymmetrical (Export) from Chassis No. 118 000 001	2 2	M 124/M 610 M 124: 113, 114, 117, 118, 151, 152
40	N 17 763 2	Halogen headlamp bulb YD 12 V 60/55 W (Germany) from Chassis No. 112 2481 144	2	M 551: 113, 114, 117, 118, 151, 152
(40)	N 17 763 2 Z	Halogen headlamp bulb YD 12 V 60/55 W (Export) from Chassis No. 112 2481 144	2	M 551: 113, 114, 117, 118, 151, 152
(40)	N 17 764 2	Halogen headlamp bulb YD 12 V 60/55 W (yellow glass) (Germany) from Chassis No. 112 2481 144	2	M 124/M 551: 113, 114, 117, 118, 151, 152
(40)	N 17 764 2 Z	Halogen headlamp bulb YD 12 V 60/55 W (Export) yellow glass from Chassis No. 112 2481 144	2	M 124/M 551: 113, 114, 117, 118, 151, 152
41	N 17 717 1	Bulb HL 6 V 4 W – Parking light (Headlamp asymmetrical) up to Chassis No. 117 999 000 from Chassis No. 118 000 001	2 2	111, 112, 115, 116
42	N 17 717 2	Bulb HL 12 V 4 W – Parking light (Headlamp asymmetrical) from Chassis No. 118 000 001	2 2	M 610 113, 114, 117, 118, 151, 152
43	111 941 161 A *	Sealed Beam Unit 6 V up to Chassis No. 117 999 000 from Chassis No. 118 000 001	2 2	M 22 M 22: 111, 112, 115, 116
44	111 941 163 A *	Lock ring – Sealed Beam Unit up to Chassis No. 117 999 000	2	M 22
-	111 941 165 C	Connector plug up to Chassis No. 115 999 000	2	
45	111 941 171 A *	Retaining spring – Sealed Beam Unit up to Chassis No. 117 999 000	10	M 22



Key No.	Part No.	Description	Quantity	Type and model
46	111 941 173 A	* Bulb socket - Parking light (Sealed Beam) ..... up to Chassis No. 117 999 000	1	M 22
47	N 17 718 1	* Bulb G 6 V 5 W - Parking light (Sealed beam) ... up to Chassis No. 117 999 000	2	M 22
(47)	N 17 718 2	* Bulb G 12 V 5 W - Sealed Beam Headlamp ..... up to Chassis No. 117 999 000	2	M 22/M 610
48	311 941 177	* Rim for retaining ring 311 941 041 ..... from Chassis No. 117 000 001 up to 117 999 000 from Chassis No. 118 000 001	2 2	M 611 M 22, M 23
(49)	111 941 185	Cable sleeve between headlamp ..... housing and front panel up to Chassis No. 6 502 399	2	
(49)	111 941 185 A	Cable sleeve between headlamp housing and ... side panel from Chassis No. 115 000 001 up to 116 1021 300	2	
(49)	111 941 185 B	Cable sleeve between headlamp housing and ... side panel from Chassis No. 117 000 001 up to 117 999 000	2	
49	111 941 185 C	* Cable sleeve between headlamp housing and ... side panel from Chassis No. 117 000 001 up to 117 999 000 from Chassis No. 118 000 001	2 2	M 611 M 22, M 23
(50)	111 941 187	Drain tube - Headlamp housing ..... from Chassis No. 2 528 668 up to 116 809 563	2	
50	141 941 147	Drain tube - Headlamp housing ..... from Chassis No. 116 809 564	2	
-	111 941 189	* Grommet 10X4 - Headlamp housing ..... up to Chassis No. 117 999 000	2	M 22
51	111 941 191	Gasket between headlamp and fender ..... up to Chassis No. 117 999 000	2	
-	N 11 372 3	Tapping screw, cheese head B 3.9X6.5 ..... for ground strap	2	

Key No.	Part No.	Description	Quantity	Type and model
52	111 941 195	Mounting screw - Headlamp up to Chassis No. 117 999 000	2	
(52)	311 941 195	Screw, countersunk raised head from Chassis No. 118 000 001 up to 118 431 603	2	
53	311 941 195 A *	Screw, countersunk raised head from Chassis No. 117 000 001 up to 117 999 000 from Chassis No. 118 000 001 up to 118 431 603 from Chassis No. 118 431 604	2 2 2	M 611 M 22, M 23
54	111 941 197	Distance piece - Headlamp mounting screw 8 mm length (0.315 in.) up to Chassis No. 117 999 000	2	
(54)	311 941 197	Distance piece - Headlamp mounting screw 16.5 mm length (0.649 in.) from Chassis No. 118 000 001 up to 118 431 603	2	
55	311 941 197 A	Distance piece - Headlamp mounting screw 36 mm length (1.417 in.) from Chassis No. 118 431 604	2	
56	111 941 261 A *	Sealed Beam Unit 12 V from Chassis No. 117 000 001 up to 117 999 000 from Chassis No. 118 000 001	2 2	M 611 M 22; 113, 114, 117, 118, 151, 152; M 23
57	111 941 341	Guide for flat connector from Chassis No. 116 000 001	2	

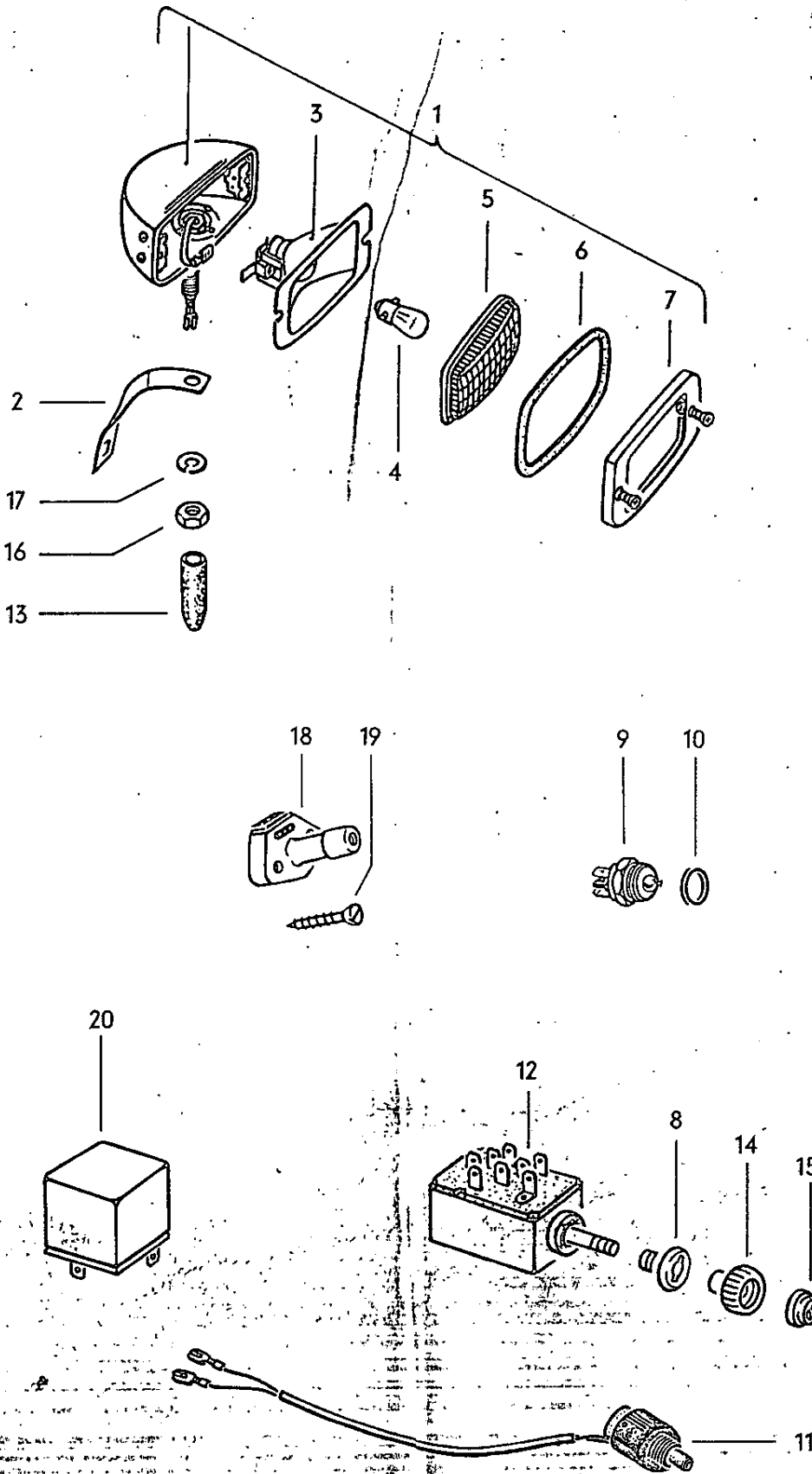
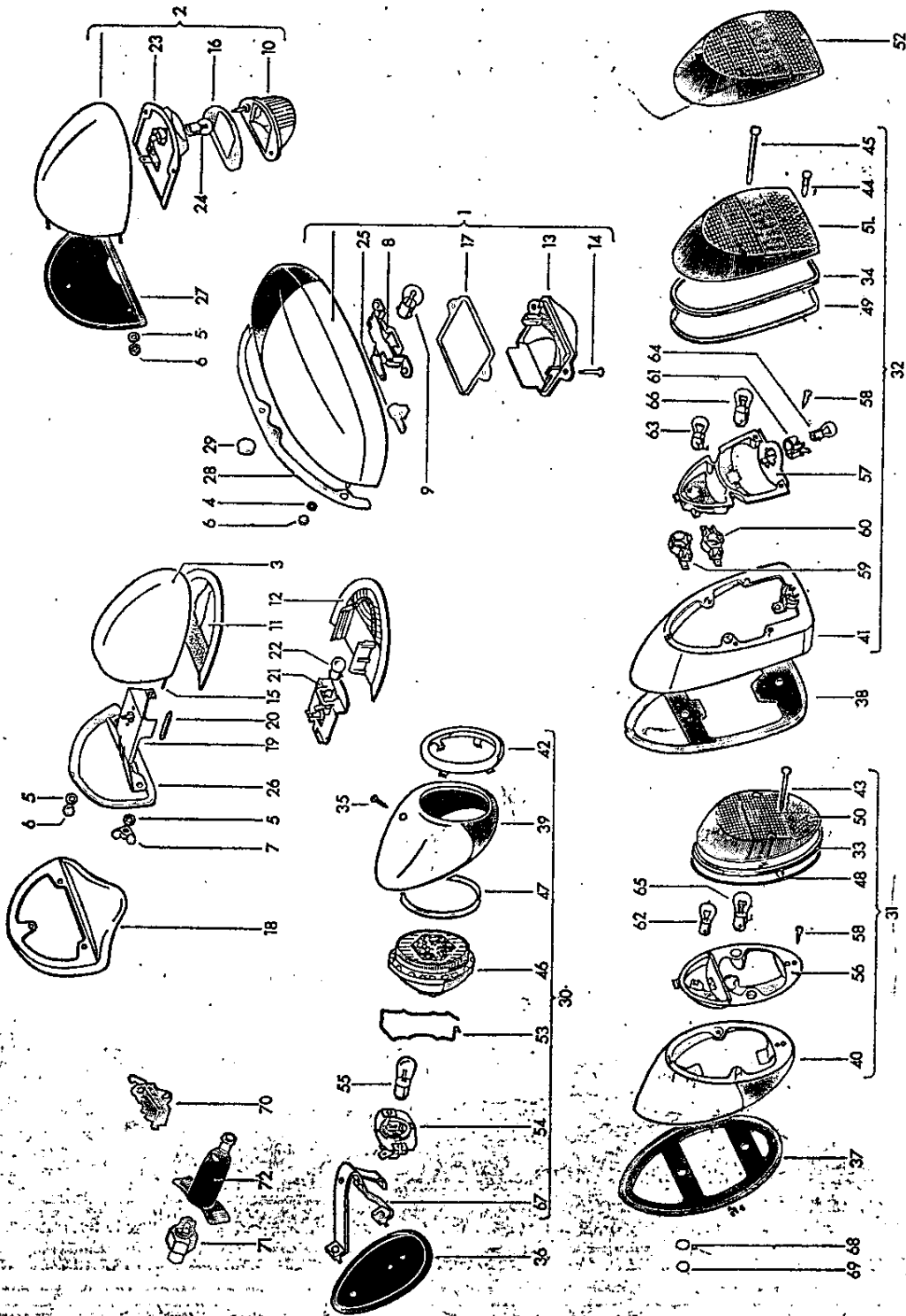

Illustration A 59

Key No.	Part No.	Description	Quantity	Type and model
<b>RETAINING RING, PUSH-PULL TYPE SWITCH RELAY</b>				
1	*111 941 072	* Back-up light ..... from Chassis No. 117 000 001	2	M 22, M 47
2	*111 941 351	* Retainer, left - Back-up light ..... from Chassis No. 117 000 001	1	M 22, M 47
(2)	*111 941 352	* Retainer, right - Back-up light ..... from Chassis No. 117 000 001	1	M 22, M 47
3	111 941 365	Headlamp reflector - Back-up light ..... from Chassis No. 117 000 001	1	M 47
4	N 17 732 1	Bulb RL 6 V 21 W - Back-up light ..... from Chassis No. 117 000 001	2	M 47
(4)	N 17 732 2	Bulb RL 12 V 21 W - Back-up light ..... from Chassis No. 117 000 001	2	M 47/M 610
5	111 941 371	Lens - Back-up light ..... from Chassis No. 117 000 001	1	M 47
6	211 945 323	Seal - Lens ..... from Chassis No. 117 000 001	1	M 47
7	111 941 375	Frame with screws - Lens ..... from Chassis No. 117 000 001	1	M 47
(8)	111 941 515	Escutcheon M 10X1 for push-pull type switch .. from Chassis No. 1 600 440 up to 117 999 000	1	
8	111 941 515 D	* Escutcheon M 14X1 for push-pull type switch .. from Chassis No. 118 000 001 up to 118 1016 100 from Chassis No. 119 000 001	1 1	M 23, M 601, M 602
(9)	113 941 521	* Switch on transmission - Back-up light ..... from Chassis No. 118 071 440	1	M 9/M 616, M 9/M 22
9	*211 941 521	* Switch on gearshift housing - Back-up light ..... from Chassis No. 117 000 001 from Chassis 151 000 001	1 1	M 22, M 23, M 47, M 601, M 602, M 603, M 616 151, 152
10	N 13 816 1	Gasket A 18X24 ..... from Chassis No. 117 000 001	1	

Key No.	Part No.	Description	Quantity	Type and model
11	271 941 521 B	Switch on speedometer – Back-up light up to Chassis No. 116 1021 300	1	
(12)	111 941 531 B	Push-pull type switch – Headlamp up to Chassis No. 1 600 439	1	
12	113 941 531	Push-pull type switch from Chassis No. 111 2000 001	1	
(12)	113 941 531 A *	Push-pull type switch – Headlamp from Chassis No. 111 2000 001	1	M 22; 113, 114; 117, 118, 151, 152
(12)	311 941 531 A	Push-pull type switch – Headlamp from Chassis No. 1 600 440 up to 117 999 000	1	
(12)	311 941 531 B	Push-pull type switch from Chassis No. 118 000 001 up to 110 3100 000	1	
13	*111 941 539 *	Boot – Back-up light from Chassis No. 117 000 001	2	M 22, M 47
(14)	111 941 541 B 0/66 – 7/67	Knob – Push-pull type switch from Chassis No. 117 000 001 up to 117 999 000 043 grey black	1	
(14)	111 941 541 E *	Knob – Push-pull type switch from Chassis No. 118 000 001 up to 118 1016 100 from Chassis No. 119 000 001 up to 110 3100 000	1 1	M 23, M 601, M 602 M 23, M 228
14	111 941 541 F	Knob – Push-pull type switch from Chassis No. 118 000 001	1	
(14)	113 941 541 10/52 – 7/63 10/52 – 7/63 8/63 – 7/65	Knob – Push-pull type switch up to Chassis No. 116 1021 300 567 ivory 466 silver beige 466 silver beige	1 1 1	113, 114, 117, 118, 151, 152 111, 112, 115, 116
(14)	*113 941 541 B *	Knob – Push-pull type switch from Chassis No. 111 2000 001	1	151, 152; M 23, M 228, M 603
15	111 941 543 G	Cap – Push-pull type switch knob from Chassis No. 118 000 001	1	
	111 941 543 L	Lens, green, with symbol for fog lamp and rear fog lamp from Chassis No. 118 000 001	x	

Key No.	Part No.	Description	Quantity	Type and model
(15)	113 941 543 B	Cap - Push-pull type lighting switch knob ..... from Chassis No. 112 2000 001	1	M 23: 113, 115, 117, 151
16	*111 941 545	* Nut, hex. - Back-up light ..... from Chassis No. 117 000 001	2	M 22, M 47
17	N 12 011 2	* Lock washer B 10 .....	2	M 22, M 47
18	111 941 561 B	Dipper switch ..... up to Chassis No. 115 999 000 up to Chassis No. 118 1016 100 from Chassis No. 118 000 001 up to 118 1016 100	1 1 1	113, 114, 117, 118, 151, 152 111, 112, 115, 116 M 110
19	N 11 484 1	Tapping screw, countersunk head B 4.8x38 ..... up to Chassis No. 115 999 000 up to Chassis No. 118 1016 100 from Chassis No. 118 000 001 up to 118 1016 100	2 2 2	113, 114, 117, 118, 151, 152 111, 112, 115, 116 M 110
(20)	311 941 581 B <i>USA</i> <i>Thru 60</i>	* Relay 6 V for low beam ..... from Chassis No. 115 000 001 up to 119 1200 000	1	M 19, M 22
(20)	311 941 581 C	Relay 6 V for low beam and headlamp flasher ... from Chassis No. 116 000 001 up to 117 999 000 from Chassis No. 118 000 001 up to 118 1016 000 from Chassis No. 119 000 001 up to 111 2799 842	1 1 1	113, 114, 117, 118, 151, 152 M 30: 111, 112, 115, 116 111, 112, 115, 116
(20)	111 941 583	Relay 12 V for low beam and headlamp flasher .. from Chassis No. 116 000 001 up to 111 2799 842 from Chassis No. 118 000 001 up to 110 3100 000 from Chassis No. 111 2000 001 up to 111 2799 842	1 1 1	M 610, M 613 113, 114, 117, 118, 151, 152 M 1
(20)	111 941 583 A <i>USA</i> <i>USA</i> <i>USA</i>	* Relay 12 V for low beam ..... from Chassis No. 117 000 001 up to 117 999 000 from Chassis No. 118 000 001 up to 119 1200 000 from Chassis No. 118 000 001 up to 110 3100 000 from Chassis No. 118 000 001 up to 111 2799 842	1 1 1 1	M 611 M 19, M 22 M 23 M 110 - <i>Plan 1000000</i>
(20)	111 941 583 B	Relay 6 V for low beam and headlamp flasher ... from Chassis No. 111 2799 843	1	111, 112, 115, 116
20	411 941 583 B	Relay 12 V for low beam and headlamp flasher ... from Chassis No. 111 2000 001 from Chassis No. 111 2799 843	1 1	113, 114, 117, 118, 151, 152 M 1: 113, 114, 117, 118; M 610, M 613
(20)	411 941 583 C	* Relay 12 V for low beam ..... from Chassis No. 111 2000 001 from Chassis No. 111 2799 843	1 1	M 23 M 108, M 110



Key No.	Part No.	Description	Quantity	Type and model
<b>LICENCE PLATE LIGHT</b>				
-	113 943 021	Licence plate light ..... from Chassis No. 5 677 119 up to 116 1021 300	1	113, 114, 117, 118, 151, 152
1	111 943 023 A SS By	Licence plate light ..... from Chassis No. 117 000 001 up to 110 3100 000	1	
-	111 943 023 B	Licence plate light ..... from Chassis No. 111 2000 001	1	
2	111 943 025 F	Licence plate light ..... from Chassis No. 1 600 440 up to 5 677 118 from Chassis No. 5 677 119 up to 116 1021 300	1 1	111, 112, 115, 116
3	111 943 111 A	Housing - Licence plate light ..... from Chassis No. 1 - 397 023 up to 1 600 439	1	
-	113 943 111	Housing - Licence plate light ..... from Chassis No. 5 677 119 up to 116 1021 300	1	113, 114, 117, 118, 151, 152
4	N 12 126 1	Shake-proof washer J 5.3 ..... from Chassis No. 5 677 119 up to 116 1021 300 from Chassis No. 117 000 001	3 3	113, 114, 117, 118, 151, 152
5	N 12 005 1	Lock washer B 5 ..... up to Chassis No. 5 677 118 from Chassis No. 5 677 119 up to 116 1021 300	3 3	111, 112, 115, 116
6	N 11 005 2	Nut, hex. M 5 .....	3	
7	N 11 173 1	Wing nut M 5 ..... from Chassis No. 1 - 397 023 up to 1 600 439	2	
8	311 943 117 C	Bulb holder - Licence plate light ..... from Chassis No. 5 677 119 up to 116 1021 300 from Chassis No. 117 000 001	1 1	113, 114, 117, 118, 151, 152
9	N 17 719 1	Bulb G 6 V 10 W ..... from Chassis No. 5 677 119 up to 116 1021 300 from Chassis No. 117 000 001 up to 117 999 000 from Chassis No. 118 000 001	1 1 1	113, 114, 117, 118, 151, 152 111, 112, 115, 116
-	N 17 719 2	Bulb G 12 V 10 W ..... from Chassis No. 5 677 119 up to 117 999 000 from Chassis No. 118 000 001	1 1	M 613 113, 114, 117, 118, 151, 152 M 613, 111, 112, 115, 116

Key No.	Part No.	Description	Quantity	Type and model
10	111 943 119	Lens - Licence plate light from Chassis No. 1 600 440 up to 5 677 118 from Chassis No. 5 677 119 up to 116 1021 300	1 1	111, 112, 115, 116
-	111 943 121	Lens - Licence plate light up to Chassis No. 1 - 397 022	1	
11	111 943 121 A	Lens - Licence plate light from Chassis No. 1 - 397 023 up to 1 600 439	1	
-	111 943 121 C *	Lens - Licence plate light (for USA only) up to Chassis No. 1 600 439	1	M 22
12	111 943 121 F	Lens - Licence plate light (conversion) from Chassis No. 1 - 397 023 up to 1 600 439 (see Technical Bulletin E 7)	1	
-	311 943 121	Lens - Licence plate light from Chassis No. 5 677 119 up to 116 1021 300 from Chassis No. 117 000 001 up to 118 1016 100	1 1	113, 114, 117, 118, 151, 152
13	311 943 121 A	Lens - Licence plate light from Chassis No. 119 000 001	1	
14	N 14 117 4	Screw, fillister head AM 4x15 from Chassis No. 5 677 119 up to 116 1021 300 from Chassis No. 117 000 001	2 2	113, 114, 117, 118, 151, 152
15	111 943 131	Gasket - Licence plate light lens 111 943 121 A/C/F up to Chassis No. 1 600 439	1	
16	111 943 131 B	Gasket - Licence plate light lens 111 943 119 from Chassis No. 1 600 440 up to 5 677 118 from Chassis No. 5 677 119 up to 116 1021 300	1 1	111, 112, 115, 116
17	311 943 131	Gasket - Licence plate light lens 113/311 943 121 from Chassis No. 5 677 119 up to 116 1021 300 from Chassis No. 117 000 001	1 1	113, 114, 117, 118, 151, 152
18	111 943 145	Base - Licence plate light (conversion) up to Chassis No. 1 - 397 022 (see Technical Bulletin E 7)	1	
19	111 943 161 A	Bulb holder - Licence plate light from Chassis No. 1 - 397 023 up to 1 600 439	1	
20	N 17 723 1	Bulb K 6 V 10 W - Licence plate light from Chassis No. 1 - 397 023 up to 1 600 439	1	

Key No.	Part No.	Description	Quantity	Type and model
-	N 17 731 1	Bulb R 6 V 18 W ..... up to Chassis No. 1 - 397 022	1	
-	N 17 718 1	Bulb G 6 V 5 W ..... up to Chassis No. 1 397 022	1	
21	111 943 161 F	Bulb holder - Licence plate light (conversion) ... from Chassis No. 1 - 397 023 up to 1 600 439 (see Technical Bulletin E 7)	1	
22	N 17 719 1	Bulb G 6 V 10 W ..... from Chassis No. 1 - 397 023 up to 1 600 439	1	
23	111 943 161 G	Bulb holder - Licence plate light ..... from Chassis No. 1 600 440 up to 5 677 118 from Chassis No. 5 677 119 up to 116 1021 300	1 1	111, 112, 115, 116
24	N 17 718 1	Bulb G 6 V 5 W ..... from Chassis No. 1 600 440 up to 5 677 118 from Chassis No. 5 677 119	1 1	111, 112, 115, 116
-	311 943 169	Grommet - Licence light ..... from Chassis No. 5 677 119 up to 115 250 500	1	113, 114, 117, 118, 151, 152
25	311 943 169 A	Grommet - Licence plate light ..... from Chassis No. 115 250 501 up to 116 1021 300 from Chassis No. 117 000 001 up to 118 1016 100	1 1	113, 114, 117, 118, 151, 152
-	111 943 191	Gasket - Stop and licence plate light ..... up to Chassis No. 1 - 397 022	1	
26	111 943 191 A	Gasket - Licence plate light ..... from Chassis No. 1 - 397 023 up to 1 600 439	1	
27	111 943 191 C	Gasket - Licence plate light ..... from Chassis No. 1 600 440 up to 5 677 118 from Chassis No. 5 677 119 up to 116 1021 300	1 1	111, 112, 115, 116
28	111 943 191 D	Gasket - Licence plate light ..... from Chassis No. 117 000 001	1	
-	113 943 191	Gasket - Licence plate light ..... from Chassis No. 5 677 119 up to 116 1021 300	1	113, 114, 117, 118, 151, 152
29	211 831 449	Plug 23 ..... from Chassis No. 5 677 119 up to 116 1021 300 from Chassis No. 117 000 001	1 1	113, 114, 117, 118, 151, 152
-	111 943 197	* Gasket - Disc (for USA only) ..... up to Chassis No. 1 600 439	1	M 22
-	111 943 381	Relay 6 V - Licence plate light ..... up to Chassis No. 117 999 000 from Chassis No. 118 000 001 up to 111 2799 842	1 1	M 30 M 30: 111, 115



Key No.	Part No.	Description	Quantity	Type and model
-	111 943 383 B	Relay 12 V - Licence plate light from Chassis No. 111 2000 001 from Chassis No. 111 2799 843	1 1	M 30: 113, 117, 151 M 30/M 610: 111, 115; M 1/M 30: 113, 117
-	111 943 383 C	Relay 12 V - Licence plate light from Chassis No. 118 000 001 up to 110 3100 000 up to Chassis No. 111 2799 842	1 1	M 30: 113, 117, 151 M 30/M 610: 111, 115; M 1/M 30: 113, 117
-	111 943 383 E	Relay 6 V - Licence plate light from Chassis No. 111 2799 843	1	M 30: 111, 115

TAIL LIGHT

30	111 945 095 C	Brake light, left up to Chassis No. 3 856 471 (Germany) up to Chassis No. 4 010 994 (export)	1	
-	111 945 095 H	Brake/indicator light, left (Sweden only) from Chassis No. 4 010 995 up to 117 507 257	1	M 18
31	111 945 095 M *	Brake/indicator light, left (yellow/red) from Chassis No. 3 856 472 up to 117 999 000 (Germany) from Chassis No. 4 010 995 up to 117 999 000 (export) from Chassis No. 118 000 001 from Chassis No. 110 2000 001	1 1 1 1	111, 112, 115, 116 M 22: 111, 112, 115, 116
-	111 945 095 N *	Brake/indicator light, left (red/red) from Chassis No. 4 010 995 up to 117 999 000 from Chassis No. 118 000 001 up to 119 1200 000	1 1	M 22 M 22: 111, 112, 115, 116
32	111 945 095 P *	Brake/indicator light, left (yellow/red) from Chassis No. 118 000 001 up to Chassis No. 119 1200 000	1 1	113, 114, 117, 118, 151, 152 M 22
-	111 945 095 Q *	Brake/indicator light, left (yellow/red/white) with back-up light from Chassis No. 118 000 001 from Chassis No. 110 2000 001 up to 110 3100 000 from Chassis No. 111 2000 001	1 1 1	M 616 M 22: 113, 114, 117, 118, 151, 152; M 603 151, 152; M 22: 113, 114, 117, 118; M 603
-	111 945 095 R *	Brake/indicator light, left (red/white) with back-up light from Chassis No. 118 000 001 up to 119 1200 000	1	M 23, M 110
-	113 945 095	Brake/indicator light, left (red/white) with back-up light from Chassis No. 110 2000 001 up to 110 3100 000	1	M 23, M 108, M 110

MAIN GROUP



ELECTRICAL EQUIPMENT

Tail light

Key No.	Part No.	Description	Quantity	Type and model
-	113 945 095 A *	Brake/indicator light, left (red/white) ..... from Chassis No. 111 2000 001	1	M 23, M 108, M 110
-	111 945 096 C	Brake light, right ..... up to Chassis No. 3 856 471 (Germany) up to Chassis No. 4 010 994 (export)	1	
-	111 945 096 H	Brake/indicator light, right (Sweden only) ..... from Chassis No. 4 010 995 up to 117 507 257	1	M 18
-	111 945 096 M *	Brake/indicator light, right (yellow/red) ..... from Chassis No. 3 856 472 up to 117 999 000 (Germany) from Chassis No. 4 010 995 up to 117 999 000 (export) from Chassis No. 118 000 001 from Chassis No. 110 2000 001	1 1 1 1	111, 112, 115, 116 M 22: 111, 112, 115, 116
-	111 945 096 N * USA	Brake/indicator light, right (red/red) ..... from Chassis No. 4 010 995 up to 117 999 000 from Chassis No. 118 000 001 up to 119 1200 000	1 1	M 22 M 22: 111, 112, 115, 116
-	111 945 096 P *	Brake/indicator light, right (yellow/red) ..... from Chassis No. 118 000 001 up to Chassis No. 119 1200 000	1 1	113,114,117,118,151,152 M 22
-	111 945 096 Q *	Brake/indicator light, right (yellow/red/white) ..... with back-up light from Chassis No. 118 000 001 from Chassis No. 110 2000 001 up to 110 3100 000  from Chassis No. 111 2000 001	1 1 1	M 616 M 22: 113, 114, 117, 118, 151, 152; M 603 151, 152; M 22: 113, 114, 117, 118; M 603
-	111 945 096 R *	Brake/indicator light, right (red/white) ..... with back-up light from Chassis No. 118 000 001 up to 119 1200 000	1	M 23, M 110
-	113 945 096	* Brake/indicator light, right (red/white) ..... with back-up light from Chassis No. 110 2000 001 up to 110 3100 000	1	M 23, M 108, M 110
-	113 945 096 A *	Brake/indicator light, right (red/white) ..... from Chassis No. 111 2000 001	1	M 23, M 108, M 110
-	113 945 103 A *	Reflector - Bumper, rear ..... from Chassis No. 110 2000 001 up to 110 3100 000	2	M 23, M 110
-	113 945 109 *	Reflector, side, rear left ..... from Chassis No. 110 2000 001	1	M 23, M 108, M 110
-	113 945 110 *	Reflector, side, rear right ..... from Chassis No. 110 2000 001	1	M 23, M 108, M 110



Key No.	Part No.	Description	Quantity	Type and model
-	111 945 111 B	Brake light housing, left from Chassis No. 1 - 397 023 up to 1 - 929 745	2	
-	111 945 112 B	Brake light housing; right from Chassis No. 1 - 397 023 up to 1 - 929 745	2	
33	111 945 117	Frame - Lens from Chassis No. 3 856 472 up to 117 999 000 from Chassis No. 118 000 001	2	111, 112, 115, 116
34	111 945 117 A	Frame - Lens from Chassis No. 118 000 001	2	113, 114, 117, 118, 151, 152
-	111 945 117 B *	Frame - Lens from Chassis No. 111 2000 001	2	M 23, M 108, M 110
-	111 945 121	Lens - Brake light, orange from Chassis No. 1 - 397 023 up to 1 - 929 745	2	
-	111 945 121 B	Lens - Brake light, red from Chassis No. 1 - 397 023 up to 1 - 929 745	2	
-	111 945 125	Spring - Brake light lens from Chassis No. 1 - 397 023 up to 1 - 929 745	2	
-	111 945 131	Tail light lens with rim up to Chassis No. 1 - 397 022	2	
-	111 945 131 B	Tail light lens with rim from Chassis No. 1 - 397 023 up to 1 - 929 745	2	
-	111 945 131 D *	Tail light lens with rim (for USA only) up to Chassis No. 1 - 871 206	2	M 22
-	113 945 139 *	Packing - Reflector, side from Chassis No. 110 2000 001	2	M 23, M 108, M 110
-	111 945 145 A	Retainer spring - Tail light lens up to Chassis No. 1 - 397 022	2	
-	113 945 159 *	Housing - Reflector, left from Chassis No. 110 2000 001 up to 110 3100 000	1	M 23, M 110
-	113 945 160 *	Housing - Reflector, right from Chassis No. 110 2000 001 up to 110 3100 000	1	M 23, M 110
-	N 15 442 1	Speed nut B 4.2x12.8 from Chassis No. 110 2000 001 up to 110 3100 000	2	M 23, M 110



Key No.	Part No.	Description	Quantity	Type and model
-	N 13 966 1	* Tapping screw, fillister hd. BZ 4.2×13 from Chassis No. 110 2000 001 up to 110 3100 000	2	M 23, M 110
-	N 10 212 3	* Bolt, hex. hd. M 6×12 from Chassis No. 110 2000 001 up to 110 3100 000	2	M 23, M 110
-	N 12 226 2	* Spring washer B 6 from Chassis No. 110 2000 001 up to 110 3100 000	2	M 23, M 110
-	N 11 006 2	* Nut, hex. M 6 from Chassis No. 110 2000 001 up to 110 3100 000	2	M 23, M 110
-	111 945 161	Base plate – Reflector and tail light, left up to Chassis No. 1 – 397 022	1	
-	111 945 161 B	Bulb holder, left from Chassis No. 1 – 397 023 up to 1 – 929 745	1	
-	111 945 162	Base plate – Reflector and tail light, right up to Chassis No. 1 – 397 022	1	
-	111 945 162 B	Bulb holder, right from Chassis No. 1 – 397 023 up to 1 – 929 745	1	
-	N 17 718 1	Bulb G 6 V 5 W – Tail light up to Chassis No. 1 – 929 745	2	
-	N 17 731 1	Bulb R 6 V 18 W – Stop light up to Chassis No. 1 – 929 745	2	
35	111 945 185	Phillips screw for brake light up to Chassis No. 3 856 471 (Germany) up to Chassis No. 4 010 994 (export)	2	
-	111 945 191	Gasket between tail light and fender up to Chassis No. 1 – 397 022	2	
-	111 945 191 A	Gasket – Brake light to fender from Chassis No. 1 – 397 023 up to 1 – 929 745	2	
36	111 945 191 B	Gasket between brake light and fender from Chassis No. 1 – 929 746 up to 3 856 471 (Germany) from Chassis No. 1 – 929 746 up to 4 010 994 (export)	2	
-	111 945 191 C	Gasket between brake/indicator light and fender (for Australia and Italy only) from Chassis No. 3 192 507 up to 4 010 994	2	M 32



Key No.	Part No.	Description	Quantity	Type and model
37	111 945 191 E	Gasket between brake/indicator light and fender from Chassis No. 3 856 472 up to 117 999 000 (Germany)	2	
		from Chassis No. 4 010 995 up to 117 999 000 (export)	2	
		from Chassis No. 118 000 001	2	111, 112, 115, 116
38	111 945 191 G	Gasket - Brake/indicator light to fender, left from Chassis No. 118 000 001	1	113, 114, 117, 118, 151, 152
-	113 945 191	* Gasket - Brake/indicator light to fender, left from Chassis No. 111 2000 001	1	M 23, M 108, M 110
-	111 945 192 A	Gasket - Brake/indicator light to fender, right from Chassis No. 118 000 001	1	113, 114, 117, 118, 151, 152
-	113 945 192	* Gasket - Brake/indicator light to fender, right from Chassis No. 111 2000 001	1	M 23, M 108, M 110
-	111 941 189	Grommet (for Australia and Italy only) from Chassis No. 3 192 507 up to 4 010 994	2	M 32
-	111 945 203	Lens with bezel (yellow/red) for brake/indicator light from Chassis No. 112 2000 001	2	111, 112, 115, 116
-	111 945 203 A	Lens with bezel (yellow/red) for brake/indicator light from Chassis No. 112 2000.001	2	113, 114, 117, 118
-	111 945 203 B	Lens with bezel (yellow/red/white) for brake/indicator light from Chassis No. 112 2000 001	2	151, 152; M 22, M 603, M 616
39	111 945 215	Brake light housing, left from Chassis No. 1 - 929 746 up to 3 856 471 (Germany)	1	
		from Chassis No. 1 - 929 746 up to 4 010 994 (export)	1	
40	111 945 215 A	Brake indicator light, housing, left from Chassis No. 3 856 472 up to 117 999 000 (Germany)	1	
		from Chassis No. 4 010 995 up to 117 999 000 (export)	1	
		from Chassis No. 118.000 001	1	111, 112, 115, 116

Key No.	Part No.	Description	Quantity	Type and model
41	111 945 215 B	Brake/indicator light, housing, left from Chassis No. 118 000 001	1	113, 114, 117, 118, 151, 152
-	113 945 215	* Housing - Brake/indicator light, left from Chassis No. 110 2000 001 up to 110 3100 000	1	M 23, M 110
-	113 945 215 A	* Housing - Brake/indicator light, left from Chassis No. 111 2000 001	1	M 23, M 108, M 110
-	111 945 216	Brake light, housing, right from Chassis No. 1 - 929 746 up to 3 856 471 (Germany) from Chassis No. 1 - 929 746 up to 4 010 994 (export)	1	
-	111 945 216 A	Brake/indicator light, housing, right from Chassis No. 3 856 472 up to 117 999 000 (Germany) from Chassis No. 4 010 995 up to 117 999 000 (export) from Chassis No. 118 000 001	1 1 1	111, 112, 115, 116
-	111 945 216 B	Brake/indicator light, housing, right from Chassis No. 118 000 001	1	113, 114, 117, 118, 115, 152
-	113 945 216	* Housing - Brake/indicator light, right from Chassis No. 110 2000 001 up to 110 3100 000	1	M 23, M 110
-	113 945 216 A	* Housing - Brake/indicator light, right from Chassis No. 111 2000 001	1	M 23, M 108, M 110
42	111 945 219	Bezel from Chassis No. 1 - 929 746 up to 3 856 471 (Germany) from Chassis No. 1 - 929 746 up to 4 010 994 (export)	2	
-	111 945 219 A	Bezel prime-coated from Chassis No. 1 - 929 746 up to 3 856 471	2	M 149
-	111 945 229 C	Lens - Brake/indicator light up to Chassis No. 117 907 257	2	M 18
43	N 14 134 1	Screw, fillister head BM 4x45 up to Chassis No. 117 999 000 from Chassis No. 118 000 001	4 4	111, 112, 115, 116
44	N 44 117 1	Screw, fillister head BM 4x17 from Chassis No. 118 000 001	2	113, 114, 117, 118, 151, 152



Key No.	Part No.	Description	Quantity	Type and model
-	N 44 129 1	Screw, fillister hd. BM 4×80 ..... from Chassis No. 111 2000 001	4	M 23, M 108, M 110
45	N 44 130 1	Screw, fillister head BM 4×72 ..... from Chassis No. 118 000 001	4	113, 114, 117, 118, 151, 152
46	111 945 231	Reflector and lens ..... from Chassis No. 1 - 929 746 up to 3 856 471 (Germany) from Chassis No. 1 - 929 746 up to 4 010 994 (export)	2	
-	113 945 231	* Bulb holder - Brake/indicator light ..... from Chassis No. 111 2000 001	2	M 23, M 108, M 110
-	111 945 233	Lens - Brake/indicator light ..... (for Australia and Italy only) up to Chassis No. 4 010 994	2	M 32
-	N 14 124 2	Screw, fillister head BM 4×35 ..... up to Chassis No. 4 010 994	4	M 32
47	111 945 235	Seal between reflector and housing ..... from Chassis No. 1 - 929 746 up to 3 856 471 (Germany) from Chassis No. 1 - 929 746 up to 4 010 994 (export)	2	
48	111 945 235 A	Gasket - Lens 111 945 229/A ..... up to Chassis No. 117 999 000 from Chassis No. 118 000 001	2 2	111, 112, 115, 116
49	111 945 235 B	Gasket - Lens ..... from Chassis No. 118 000 001	2	113, 114, 117, 118, 151, 152
-	111 945 235 C	* Gasket - Lens ..... from Chassis No. 111 2000 001	2	M 23, M 108, M 110
-	111 945 241 D	* Lens (red) - Brake/indicator light ..... from Chassis No. 4 010 995 up to 117 999 000 from Chassis No. 118 000 001 up to 119 1200 000	2 2	M 22 M 22: 111, 112, 115, 116
-	111 945 241 H	* Lens (red) - Brake/indicator light ..... from Chassis No. 118 000 001 up to 119 1200 000	2	M 22: 113, 114, 117, 118, 151, 152
-	111 945 241 J	* Lens (red/white) - Brake/indicator light ..... with back-up lamp, left from Chassis No. 118 000 001 up to 119 1200 000	1	M 23, M 616/M 22: 113, 114, 117, 118, 151, 152

Key No.	Part No.	Description	Quantity	Type and model
50	111 945 241 K	* Lens (yellow/red) – Brake/indicator light ..... from Chassis No. 3 856 472 up to 117 999 000 (Germany) from Chassis No. 4 010 995 up to 117 999 000 (export) from Chassis No. 118 000 001 from Chassis No. 110 2000 001	2 2 2 2	111, 112, 115, 116 M 22: 111, 112, 115, 116
51	111 945 241 L	Lens (yellow/red) – Brake/indicator light ..... from Chassis No. 118 000 001 up to 110 3100 000 from Chassis No. 111 2000 001	2 2	113, 114, 117, 118, 151, 152 113, 114, 117, 118
-	111 945 241 M	* Lens (yellow/red/white) – Brake/indicator light ... from Chassis No. 118 000 001 from Chassis No. 110 2000 001 up to 110 3100 000  from Chassis No. 111 2000 001	2 1 1	M 601, M 616 M 22: 113, 114, 117, 118, 151, 152; M 603 151, 152; M 22: 113, 114, 117, 118; M 603
52	113 945 241	* Lens (red/white) – Brake/indicator light, left ..... from Chassis No. 110 2000 001 up to 110 3100 000	1	M 23/M 110
-	113 945 241 A	* Lens (red/white) – Brake/indicator light, left ..... from Chassis No. 111 2000 001	1	M 23, M 108, M 110
-	111 945 242	* Lens (red/white) – Brake/indicator light ..... with back-up light, right from Chassis No. 118 000 001 up to 119 1200 000	1	M 23, M 616/M 22: 113, 114, 117, 118, 151, 152
-	113 945 242	* Lens (red/white) – Brake/indicator light, right ..... from Chassis No. 110 2000 001 up to 110 3100 000	1	M 23, M 110
-	113 945 242 A	* Lens (red/white) – Brake/indicator light, right ..... from Chassis No. 111 2000 001	1	M 23, M 108, M 110
53	111 945 245	Spring clip – Reflector ..... from Chassis No. 1 – 929 746 up to 3 856 471 (Germany) from Chassis No. 1 – 929 746 up to 4 010 994 (export)	2	
54	111 945 261 C	* Bulb holder – Brake light ..... from Chassis No. 1 – 929 746 up to 3 856 471 (Germany) from Chassis No. 1 – 929 746 up to 4 010 994 (export)	2	
55	N 17 737 1	* Bulb S 6 V 18/5 W .....	2	
-	111 945 261 D	* Bulb holder – Brake/indicator light ..... (for Australia and Italy only) up to Chassis No. 4 010 994	2	M 32

Key No.	Part No.	Description	Quantity	Type and model
-	N 10 802 2	Screw, fillister head AM 3x6 .....	2	M 32
-	N 12 003 1	Lock washer B 3 .....	2	M 32
56	111 945 263 F	* Bulb holder - Brake/indicator light .....	2	
	SS by	from Chassis No. 3 856 472 up to 117 999 000	2	
	111 945 263 G	(Germany)	2	
		from Chassis No. 4 010 995 up to 117 999 000	2	
		(export)	2	111, 112, 115, 116
		from Chassis No. 118 000 001	2	M 22: 111, 112, 115, 116
		from Chassis No. 110 2000 001	2	
57	111 945 263 B	Bulb holder - Brake/indicator light .....	2	113, 114, 117, 118, 151, 152
		from Chassis No. 118 000 001 up to 118 1016 100		
58	N 13 965 1	Tapping screw, fillister head B 4.2x9.5 .....	2	
		up to Chassis No. 117 999 000	2	111, 112, 115, 116
		from Chassis No. 118 000 001	2	
		from Chassis No. 118 000 001	4	113, 114, 117, 118, 151, 152
-	111 945 263 D	* Bulb holder - Brake/indicator light .....	2	113, 114, 117, 118, 151, 152;
		from Chassis No. 119 000 001		M 22: 113, 114, 117, 118,
				151, 152
-	111 945 263 G	* Bulb holder - Brake/indicator light .....	2	M 22
		from Chassis No. 4 010 995 up to 117 999 000	2	
		from Chassis No. 118 000 001 up to 119 1200 000	2	M 22: 111, 112, 115, 116
-	113 945 263	* Bulb holder - Brake/indicator light .....	2	M 23, M 110
		from Chassis No. 110 2000 001 up to 110 3100 000		
59	111 945 265	Bulb holder - Indicator light .....	2	113, 114, 117, 118, 151, 152
		from Chassis No. 118 000 001		
60	111 945 267	Bulb holder - Brake/tail light .....	2	113, 114, 117, 118, 151, 152
		from Chassis No. 118 000 001		
61	*111 945 269	* Bulb holder - Back-up light .....	x	113, 114, 117, 118, 151, 152
		from Chassis No. 118 000 001	2	M 22: 113, 114, 117, 118,
		from Chassis No. 110 2000 001	2	151, 152
62	N 17 731 1	Bulb R 6 V 18 W .....	2	
		up to Chassis No. 117 999 000	2	
		from Chassis No. 118 000 001	2	111, 112, 115, 116
-	N 17 731 2	Bulb R 12 V 18 W .....	2	M 613
		up to Chassis No. 116 1021 300		
63	N 17 732 2	Bulb RL 12 V 21 W .....	2	M 610
		from Chassis No. 117 000 001	2	
		from Chassis No. 118 000 001	2	113, 114, 117, 118, 151, 152

Key No.	Part No.	Description	Quantity	Type and model
64	N 17 732 2	Bulb RL 12 V 21 W from Chassis No. 118 000 001 up to 110 3100 000 from Chassis No. 111 2000 001	2 2	M 601, M 616 151, 152; M 603, M 616
65	N 17 737 1	Bulb S 6 V 18/5 W up to Chassis No. 117 999 000 from Chassis No. 118 000 001	2 2	111, 112, 115, 116
-	N 17 737 2	Bulb S 12 V 18/5 W	2	M 613
66	N 17 738 2	Bulb SL 12 V 21/5 W from Chassis No. 117 000 001 from Chassis No. 118 000 001	2 2	M 611 113, 114, 117, 118, 151, 152
67	111 945 291	Mounting bracket, left from Chassis No. 1 - 929 746 up to 3 856 471 (Germany only) from Chassis No. 1 - 929 746 up to 4 010 994 (Export only)	1	
-	111 945 292	Mounting bracket, right from Chassis No. 1 - 929 746 up to 3 856 471 (Germany only) from Chassis No. 1 - 929 746 up to 4 010 994 (Export only)	1	
68	N 12 126 1	Shake-proof washer J 5.3	4	
69	N 11 005 2	Nut, hex. M 5	4	
70	111 945 511	Switch - Brake light up to Chassis No. 4 630 937	1	111, 112, 115, 116
-	N 10 715 2	Screw, cheese head AM 6x15	2	111, 112, 115, 116
-	N 12 226 2	Spring washer B 6	2	111, 112, 115, 116
71	113 945 515 C SS by 113945515H	Switch - Brake light (2 points) up to Chassis No. 4 630 937 Single circuit brake: from Chassis No. 4 630 938 up to 119 1200 000 Dual circuit brake: from Chassis No. 117 000 001 up to 110 3100 000 from Chassis No. 111 2000 001 up to 111 3200 000	1 1 2 2	113, 114, 117, 118, 151, 152 111-118
-	113 945 515 D SS by 113945515G	* Warning switch - Brake light switch (3 points) from Chassis No. 110 2000 001 up to 110 3100 000 from Chassis No. 111 2000 001 up to 111 3200 000	2 2	M 23, M 50, M 110, M 603 151, 152; M 23, M 50, M 108 M 110, M 602, M 603

Key No.	Part No.	Description	Quantity	Type and model
-	113 945 515 E	* Warning switch - Tandem master cylinder ..... from Chassis No. 118 000 001 up to 119 1200 000	1	M 23, M 50, M 110
-	113 945 515 G	* Warning switch - Brake light switch (3 points) ... from Chassis No. 112 2000 001	2	151, 152; M 23, M 50, M 108, M 110, M 602, M 603
-	113 945 515 H	Switch - Brake light (2 points) ..... from Chassis No. 112 2000 001	2	111-118
-	111 945 521	Boot - Brake light switch (2 points) ..... from Chassis No. 112 2000 001	2	111-118
-	113 945 521 A	*Boot - Brake light switch (3 points) ..... from Chassis No. 112 2000 001	2	151, 152; M 23, M 50, M 108, M 110, M 602, M 603
-	111 945 525	Terminal sleeve housing, 2 pin for brake light ... switch from Chassis No. 112 2000 001	2	111-118
-	113 945 525	* Terminal sleeve housing, 3 pin for brake light ... switch from Chassis No. 112 2000 001	2	151, 152; M 23, M 50, M 108, M 110, M 602, M 603
-	411 941 539	Boot - Brake light switch ..... from Chassis No. 110 2000 001 up to 111 3100 000	2	
72	111 963 355	Boot - Brake light switch ..... Single circuit brake: from Chassis No. 117 000 001 up to 119 1200 000	1	
		Dual circuit brake: from Chassis No. 117 000 001 up to 119 1200 000	2	



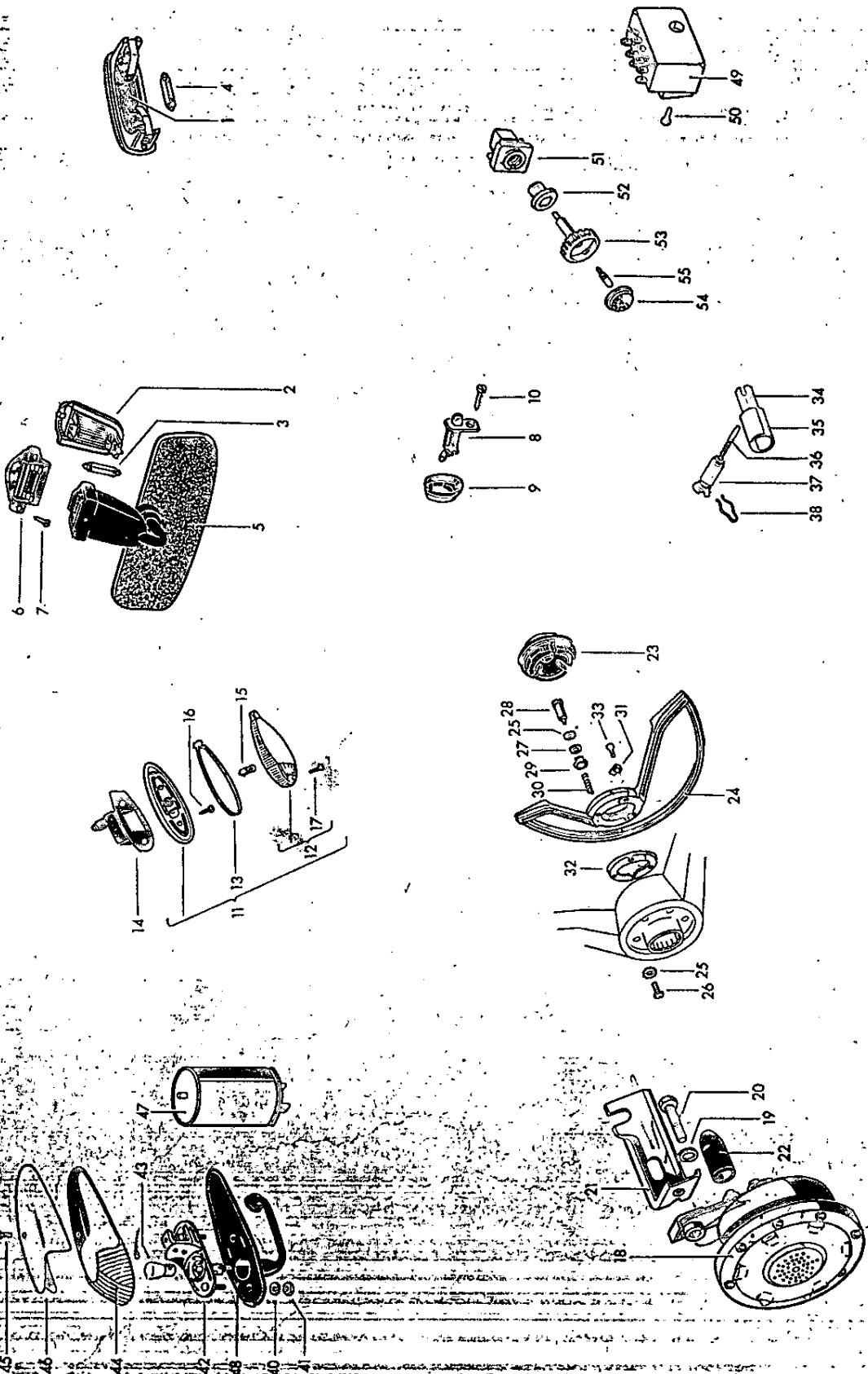

Key No.	Part No.	Description	Quantity	Type and model
<b>INTERIOR LIGHT</b>				
(1)	151 947 103	Interior light ..... up to Chassis No. 1 600 439	1	151, 152
(1)	111 947 111 D	Interior light with switch ..... from Chassis No. 1 - 397 023 up to May 1972	1	111-118
1	111 947 111 E	Interior light with switch ..... from Chassis No. June 1972	1	111-118
(2)	151 947 111 A	Interior light without switch ..... from Chassis No. 1 600 440 up to 6 502 399	1	151, 152
(2)	151 947 111 B	Interior light with switch ..... from Chassis No. 155 000 001 up to 157 999 000	1	151, 152
2	151 947 111 C	Interior light with switch ..... from Chassis No. 158 000 001	1	151, 152
(3)	N 17 717 1	Bulb HL 6 V 4 W ..... from Chassis No. 155 000 001 up to 157 999 000	1	151, 152
3	N 17 717 2	Bulb HL 12 V 4 W ..... up to Chassis No. 158 000 001	1	151, 152
(4)	N 17 723 1	Bulb K 6 V 10 W ..... up to Chassis No. 6 502 399 from Chassis No. 115 000 001 up to 117 999 000 from Chassis No. 118 000 001	1 1 1	111-118 111, 112, 115, 116
4	N 17 723 2	Bulb K 12 V 10 W ..... from Chassis No. 118 000 001	1 1	M 610: 113, 114, 117, 118
-	111 947 125	Lens - Interior light ..... up to Chassis No. 1 - 397 022	1	111-118
(5)	151 947 131	Rear view mirror without interior light ..... from Chassis No. 158 000 001 up to 150 3100 000 (to Ch. No. 157 999 000; see 151 R57.511/A)	1	151, 152
5	151 947-131 B	Rear view mirror without interior light, anti-dazzle from Chassis No. 158 000 001 up to 150 3100 000 from Chassis No. 151.2000 001	1 1	M 206, 151, 152 151, 152
6	151 947 133	Retainer - Rear view mirror ..... from Chassis No. 158 000 001	1	151, 152

88  
BY

Key No.	Part No.	Description	Quantity	Type and model
7	N 13 997 1	Tapping screw, countersunk head B 4.2×13 from Chassis No. 158 000 001	3	151, 152
-	151 947 511 A	Tumbler switch - Interior light from Chassis No. 1 - 397 023 up to 1 - 575 414 from Chassis No. 1 - 575 415 up to 6 502 399	1 1	151, 152
-	113 947 541	Knob, ivory - Tumbler switch up to Chassis No. 6 502 399	1	
(8)	113 947 561	Switch - Door contact from Chassis No. 1 - 397 023 up to 1 - 575 414	2	113, 114, 117, 118, 151, 152
-	N 10 970 1	Screw, countersunk head AM 4×8	4	113, 114, 117, 118, 151, 152
(8)	113 947 561 B	Switch - Door contact from Chassis No. 1 - 575 415 up to 3 192 506	2	113, 114, 117, 118, 151, 152
8	113 947 561 D <i>SS64</i> <i>113947561D</i>	* Switch - Door contact from Chassis No. 3 192 507 right: from Chassis No. 110 2000 001	2 1	113, 114, 117, 118, 151, 152 M 23, M 108, M 110
(8)	113 947 561 E	* Switch - Door contact, left from Chassis No. 110 2000 001 up to 112 2360 220	1	M 23, M 108, M 110
(8)	113 947 561 F	* Switch - Door contact, left from Chassis No. 112 2360 221	1	M 23, M 108, M 110
-	151 947 561	Switch - Interior light up to Chassis No. 6 502 399	1	151, 152
-	N 11 325 3	Tapping screw, countersunk head B 3.5×13 up to Chassis No. 6 502 399	2	151, 152
9	113 947 565	Seal - Door contact switch from Chassis No. 115 000 001	2	113, 114, 117, 118, 151, 152
(9)	113 947 565 A	* Seal - Door contact switch from Chassis No. 110 2000 001	1	M 23, M 108, M 110
10	N 13 958 3	Tapping screw, fillister head, B 3.5×13	2	113, 114, 117, 118, 151, 152
-	111 947 567	Cap - Door contact switch 113 947 561 F from Chassis No. 112 2360 221	1	M 23, M 108, M 110

Key No.	Part No.	Description	Quantity	Type and model
<b>SIDE FLASHING INDICATOR</b>				
from Chassis No. 118 000 001				M 46: 111, 118, 151, 152
11	311 949 101 A	Side flashing indicator (yellow) .....	2	
12	311 949 109 A	Lens (yellow) – Side flashing indicator .....	2	
13	311 949 113 A	Seal – Lens .....	2	
14	311 949 121	Gasket – Flashing Indicator .....	2	
-	N 17 717 1	Bulb HL 6 V 4 W .....	2	111, 112, 115, 116
15	N 17 717 2	Bulb HL 12 V 4 W .....	2	113, 114, 117, 118, 151, 152
16	N 13 968 1	Tapping screw, fillister head B 4.8×13 – Flashing indicator	4	
17	N 10 901 2	Screw, countersunk head AM 3×8 – Lens .....	2	

HORN

(18)	111 951 111 H	Horn 6 V .....	1	
		up to Chassis No. 117 999 000	1	
		from Chassis No. 118 000 001	1	111, 112, 115, 116
18	311 951 113 L	Horn 12 V .....	1	M 610
		from Chassis No. 118 000 001	1	113, 114, 117, 118, 151, 152
19	N 12 008 2	Lock washer B 8 .....	1	
20	N 10 242 5	Bolt, hex. head M 8×25 .....	1	
21	111 951 185	Bracket – Horn .....	1	
		from Chassis No. 118 000 001 up to 110 3100 000	1	113, 114, 117, 118, 151, 152
		from Chassis No. 111 2000 001	1	
-	111 951 185 A	Bracket – Horn .....	1	
		from Chassis No. 111 2000 001	1	113, 114, 117, 118, 151, 152
22	111 951 195 A	Grommet – Horn .....	2	
-	111 951 307	* Buzzer 12 V .....	1	M 23
		from Chassis No. 110 2000 001	1	



Key No.	Part No.	Description	Quantity	Type and model
-	111 951 501	Button black - Horn from Chassis No. 1 - 072 905 up to 116 1021 300	1	111, 112, 115, 116
-	N 13 075 1	Stud M 4x5	1	111, 112, 115, 116
-	113 951 501 A	Button - Horn from Chassis No. 1 - 072 905 up to 1 - 929 745	1	113, 114, 117, 118, 151, 152
	1/47 - 7/55	278 grey beige		
	1/47 - 7/55	567 ivory		
23	113 951 501 B	Button - Horn from Chassis No. 1 - 929 746 up to 2 528 667	1	113, 114, 117, 118, 151, 152
		from Chassis No. 1 - 929 746 up to 117 999 000	1	M 1
		from Chassis No. 1 - 929 746	1	M 11, M 110
	8/55 -	466 silver beige		
-	N 13 041 1	Stud M 2.6x5	1	113, 114, 117, 118, 151, 152
-	113 951 531 C	Horn ring from Chassis No. 2 528 668 up to 4 010 994	1	113, 114, 117, 118, 151, 152
24	113 951 531 F	Horn ring from Chassis No. 4 010 995 up to 117 999 000	1	113, 114, 117, 118, 151, 152
		from Chassis No. 118 000 001 up to 111 3200 000	1	
		from Chassis No. 112 2000 001	1	111, 112, 115, 116
25	N 12 131 2	Shake-proof washer J 3.7 up to Chassis No. 116 1021 300	6	113, 114, 117, 118, 151, 152
		from Chassis No. 117 000 001 up to 110 3100 000	6	
		from Chassis No. 112 2000 001	6	111, 112, 115, 116
26	N 10 803 1	Screw, fillister head AM 3.5x10 up to Chassis 116 1021 300	3	113, 114, 117, 118, 151, 152
		from Chassis No. 117 000 001 up to 111 3200 000	3	
		from Chassis No. 112 2000 001	3	111, 112, 115, 116
27	113 951 539	Insulating washer for horn ring mounting from Chassis No. 2 528 668 up to 116 1021 300	3	113, 114, 117, 118, 151, 152
		from Chassis No. 117 000 001 up to 111 3200 000	3	
		from Chassis No. 112 2000 001	3	111, 112, 115, 116
28	113 951 541	Screw, fillister head M 3.5x25 from Chassis No. 2 528 668 up to 116 1021 300	3	113, 114, 117, 118, 151, 152
		from Chassis No. 117 000 001 up to 111 3200 000	3	
		from Chassis No. 112 2000 001	3	111, 112, 115, 116
29	113 951 547	Insulating bush - Contact washer from Chassis No. 4 010 995 up to 111 3200 000	3	113, 114, 117, 118, 151, 152
	211 951 547 A	Insulating bush - Contact washer from Chassis No. 117 000 001 up to 111 3200 000	3	111, 112, 115, 116; M 108, M 110
		from Chassis No. 112 2000 001	3	111, 112, 115, 116

Key No.	Part No.	Description	Quantity	Type and model
-	113 951 549	Contact pin ..... from Chassis No. 2 528 668 up to 4 010 994	3	113, 114, 117, 118, 151, 152
-	111 951 555	Spring - Contact pin ..... from Chassis No. 117 000 001 up to 111 3200 000	3	111, 112, 115, 116; M 108, M 110
		from Chassis No. 112 2000 001	3	111, 112, 115, 116
-	113 951 555	Spring - Contact pin ..... from Chassis No. 2 528 668 up to 4 010 994	3	113, 114, 117, 118, 151, 152
30	113 951 555 A	Spring - Contact pin ..... from Chassis No. 4 010 995 up to 111 3200 000	3	113, 114, 117, 118, 151, 152
31	113 951 559	Clamp ..... from Chassis No. 4 010 995 up to 111 3200 000	1	113, 114, 117, 118, 151, 152
32	113 951 563	Contact washer ..... from Chassis No. 4 010 995 up to 111 3200 000	1	113, 114, 117, 118, 151, 152
-	211 951 563	Contact washer ..... from Chassis No. 117 000 001 up to 111 3200 000	1	111, 112, 115, 116; M 108, M 110
		from Chassis No. 112 2000 001	1	111, 112, 115, 116
33	N 10 695 1	Screw, cheese head AM 4x6 ..... up to Chassis No. 111 3200 000	1	113, 114, 117, 118, 151, 152
-	113 951 565	Insulating sleeve - Self-cancelling ring ..... from Chassis No. 2 528 668 up to 4 010 994	1	113, 114, 117, 118, 151, 152
34	111 951 571	Insulator - Horn ..... up to Chassis No. 2 528 667	1	
		from Chassis No. 2 528 668 up to 116 1021 300	1	111, 112, 115, 116
35	111 951 573	Collector ring - Horn ..... up to Chassis No. 2 528 667	1	
		from Chassis No. 2 528 668 up to 116 1021 300	1	111, 112, 115, 116
36	111 951 581 A	Carbon brush with spring ..... up to Chassis No. 2 528 667	1	
		from Chassis No. 2 528 668 up to 116 1021 300	1	111, 112, 115, 116
37	111 951 585	Holder - Carbon brush ..... up to Chassis No. 2 528 667	1	
		from Chassis No. 2 528 668 up to 116 1021 300	1	111, 112, 115, 116
-	111 951 589	Threaded cap - Retainer ..... up to Chassis No. 2 528 667	1	
		from Chassis No. 2 528 668 up to 3 192 506	3	111, 112, 115, 116
38	111 109 425	Spring clip ..... up to Chassis No. 2 528 667	1	
		from Chassis No. 2 528 668 up to 116 1021 300	1	111, 112, 115, 116



Key No.	Part No.	Description	Quantity	Typo and model
<b>FLASHING INDICATOR, FRONT</b>				
-	111 953 021 E	Direction indicator ..... up to Chassis No. 3 192 506	2	111-118
-	151 953 021 B	Direction indicator ..... up to Chassis No. 3 192 506	2	151, 152
-	N 17 726 1	Bulb M 6 V 3 W .....	2	
-	111 953 041 B	Flashing indicator, front (yellow) ..... up to Chassis No. 5 888 184	2	111, 112, 115, 116
-	111 953 041 D	Flashing indicator, front (yellow) ..... from Chassis No. 5 888 185	2	111, 112, 115, 116
-	*113 953 041	Flashing indicator, front (yellow) ..... up to Chassis No. 5 888 184	2	113, 114, 117, 118, 151, 152
-	113 953 041 A *	Flashing indicator, front (clear glass) ..... from Chassis No. 1 600 440 up to 5 888 184	2	M 22
-	113 953 041 B	Flashing indicator, front (clear glass - yellow) ... up to Chassis No. 5 888 184 and from Chassis No. 6 093 328 up to 115 651 940	2	M 34
-	113 953 041 G	Flashing indicator, front, left (yellow - yellow) .. from Chassis No. 116 463 103 up to 117 999 000	1	M 82
39	113 953 041 J *	Flashing indicator, front (yellow) ..... from Chassis No. 5 888 185 up to 116 1021 300 from Chassis No. 5 888 185	2 2	M 22 113, 114, 117, 118, 151, 152
-	113 953 041 K *	Flashing indicator, front (yellow) ..... from Chassis No. 117 000 001 up to 117 999 000 from Chassis No. 118 000 001 up to 119 1200 000	2 2	M 22/M 611 M 22
-	113 953 041 L	Flashing indicator, front, left (clear glass - yellow) from Chassis No. 115 651 941	1	M 34
-	113 953 041 M *	Flashing indicator, front (yellow) with side reflector from Chassis No. 118 000 001 up to 119 1200 000 from Chassis No. 110 2000 001	2 2	M 23 M 22
-	113 953 041 N *	Flashing indicator, front left (yellow) with side reflector from Chassis No. 110 2000 001	1	M 23

MAIN GROUP



ELECTRICAL EQUIPMENT

Flashing Indicator, front

Key No.	Part No.	Description	Quantity	Type and model
-	113 953 042	Flashing indicator, front, right (clear glass - yellow) from Chassis No. 115 651 941 up to 118 1016 100	1	M 34
-	113 953 042 A	Flashing indicator, front, right (yellow - yellow) .. from Chassis No. 116 463 103 up to 117 999 000	1	M 82
-	113 953 042 B	Flashing indicator, front, right (clear glass - yellow) from Chassis No. 119 000 001	1	M 34
-	113 953 042 N	Flashing indicator, front right (yellow) ..... with side reflector from Chassis No. 110 2000 001	1	M 23
40	N 12 126 1	Shake-proof washer J 5.3 .....	4	
41	N 11 005 2	Nut, hex. M 5 .....	4	
-	111 953 051 A USA	Bulb holder - Flashing indicator, front ..... up to Chassis No. 5 888 184 from Chassis No. 6 093 328 up to 115 651 940	2 2	M 34
-	111 953 051 E	Bulb holder - Flashing indicator, front ..... from Chassis No. 117 000 001 up to 118 1016 100	2	M 22
-	111 953 051 G	Bulb holder - Flashing indicator, front ..... from Chassis No. 115 651 941 up to 118 1016 100 from Chassis No. 116 463 103 up to 117 999 000	2 2	M 34 M 82
42	111 953 051 K	Bulb holder - Flashing indicator, front ..... from Chassis No. 5 888-185	2	
-	111 953 051 L	Bulb holder - Flashing indicator, front ..... from Chassis No. 119 000 001	2	M 34
-	111 953 051 M	Bulb holder - Flashing indicator, front ..... from Chassis No. 119 000 001 up to 119 1200 000	2	M 22
-	113 953 051 A USA	Bulb holder - Flashing indicator, front ..... from Chassis No. 118 000 001 up to 118 1016 100	2	M 23
-	113 953 051 B USA	Bulb holder - Flashing indicator, front ..... from Chassis No. 119 000 001 up to 119 1200 000 from Chassis No. 110 2000 001	2 2	M 23 M 22
-	113 953 051 C USA	Bulb holder - Flashing indicator, front ..... from Chassis No. 110 2000 001	2	M 23
-	211 953 051	Bulb holder - Flashing indicator, front ..... up to Chassis No. 1 600 439	2	M 22



Key No.	Part No.	Description	Quantity	Type and model
43	N 17 731 1	Bulb R 6 V 18 W ..... up to Chassis No. 117 999 000 from Chassis No. 118 000 001 up to 118 1016 100	2 2	111, 112, 115, 116
-	N 17 731 2	Bulb R 12 V 18 W ..... up to Chassis No. 116 1021 300	2	M 613
-	N 17 732 1	Bulb RL 6 V 21 W ..... from Chassis No. 119 000 001	2	111, 112, 115, 116
-	N 17 732 2	Bulb RL 12 V 21 W ..... from Chassis No. 117 000 001 from Chassis No. 118 000 001	2 2	M 610 113, 114, 117, 118, 151, 152
-	N 17 737 1	Bulb S 6 V 18/5 W ..... from Chassis No. 118 000 001 up to 118 1016 100	2	M 22: 111, 112, 115, 116
-	N 17 738 1	Bulb SL 6 V 21/5 W ..... from Chassis No. 119 000 001	2	111, 112, 115, 116
-	N 17 738 2 20P118-034 USA	Bulb SL 12 V 21/5 W ..... from Chassis No. 117 000 001 from Chassis No. 118 000 001	2 2	M 611 M 23 M 22: 113, 114, 117, 118, 151, 152
-	N 17 717 2 USA	Bulb H 12 V 4 W ..... from Chassis No. 110 2000 001	2	M 23
-	111 953 061 A	Side flashing indicator ..... up to Chassis No. 115 651 940 up to Chassis No. 116 463 102	2 2	M 34 M 46
-	N 17 717 1	Bulb HL 6 V 4 W ..... up to Chassis No. 115 651 940 up to Chassis No. 116 463 102	2 2	M 34 M 46
-	N 13 905 2	Tapping screw, button head B 2.9×9.5 ..... up to Chassis No. 115 651 940 up to Chassis No. 116 463 102	2 2	M 34 M 46
-	141 953 153	Seal between bulb holder and fender ..... up to Chassis No. 1 600 439	2	M 22
-	N.12 135 1	Shake-proof washer J 21 ..... up to Chassis No. 1 600 439	2	M 22
-	141 953 159	Nut, hex. M 20×1 ..... up to Chassis No. 1 600 439	2	M 22
-	111 953 161	Lens (clear glass) - Flashing indicator, front ..... up to Chassis No. 1 600 439	2	M 22

Key No.	Part No.	Description	Quantity	Type and model
-	N 10 866 1	* Screw, countersunk raised head M 4×10×2.5 ... up to Chassis No. 1 600 439	4	M 22
-	111 953 161 A	* Lens (clear glass) – Flashing indicator, front ..... (for USA only) from Chassis No. 1 600 440 up to 5 888 184	2	M 22
-	111 953 161 B	Lens (clear glass – yellow) – Flashing indicator, .. front up to Chassis No. 5 888 184 and from Chassis No. 6 093 328 up to 115 651 940	2	M 34
-	111 953 161 C USA	Lens (yellow) – Flashing indicator, front ..... up to Chassis No. 5 888 184	2	M 34
-	111 953 161 D	Lens (clear glass) – Flashing indicator, front ..... from Chassis No. 5 888 185 up to 6 093 327	2	M 34
-	111 953 161 F	Lens (clear glass – yellow) – Flashing indicator, .. front from Chassis No. 115 651 941	2	M 34
-	111 953 161 G	Lens (yellow – yellow) – Flashing indicator, front from Chassis No. 116 463 103 up to 117 999 000	2	M 82
-	111 953 161 H	* Lens (yellow) – Flashing indicator, front ..... from Chassis No. 5 888 185 up to 119 1200 000	2	M 22
44	111 953 161 J Thru 6)	Lens (yellow) – Flashing indicator, front ..... from Chassis No. 5 888 185	2	
-	113 953 161 A USA	* Lens (yellow) with side reflector ..... from Chassis No. 118 000 001 up to 119 1200 000 from Chassis No. 110 2000 001	2 2	M 23 M 22
-	113 953 161 B USA	* Lens (yellow) with side reflector for flashing ..... indicator, front left from Chassis No. 110 2000 001	1	M 23
45	N 14 267 5	Screw, countersunk raised head AM 5×18 ..... 2	2	
-	N 14 134 1	* Screw, fillister hd. BM 4×45 ..... from Chassis No. 110 2000 001	2	M 23
-	N 44 120 1	* Screw, fillister hd. BM 4×30×12 ..... from Chassis No. 110 2000 001	2	M 23
-	113 953 162 B	* Lens (yellow) with side reflector for flashing ..... indicator, front right from Chassis No. 110 2000 001	1	M 23



Key No.	Part No.	Description	Quantity	Type and model
-	111 953 163	* Housing - Flashing indicator, front, left ..... up to Chassis No. 1 600 439	1	M 22
-	111 953 163 C	Housing - Flashing indicator, front ..... up to Chassis No. 5 888 184	2	111, 112, 115, 116
-	111 953 163 D	Housing - Flashing indicator, front ..... from Chassis No. 5 888 185	2	111, 112, 115, 116
-	113 953 163	Housing - Flashing indicator, front ..... up to Chassis No. 5 888 184	2	113, 114, 117, 118, 151, 152
		from Chassis No. 6 093 328 up to 115 651 940	2	M 34
46	113 953 163 A	Housing - Flashing indicator, front ..... from Chassis No. 5 888 185	2	113, 114, 117, 118, 151, 152
-	113 953 163 B	Housing left - Flashing indicator, front ..... from Chassis No. 115 651 941	1	M 34
		from Chassis No. 116 463 103 up to 117 999 000	1	M 82
-	113 953 163 C	* Housing - Flashing indicator, front ..... from Chassis No. 118 000 001 up to 119 1200 000	2	M 23
		from Chassis No. 110 2000 001	2	M 22
-	113 953 163 D	* Housing - Flashing indicator, front, left ..... from Chassis No. 110 2000 001	1	M 23
-	111 953 164	* Housing - Flashing indicator, front, right ..... up to Chassis No. 1 600 439	1	M 22
-	113 953 164	Housing right - Flashing indicator, front ..... from Chassis No. 115 651 941	1	M 34
		from Chassis No. 116 463 103 up to 117 999 000	1	M 82
-	113 953 164 D	* Housing - Flashing indicator, front, right ..... from Chassis No. 110 2000 001	1	M 23
-	111 953 165	* Packing - Housing ..... up to Chassis No. 1 600 439	2	M 22
-	111 953 175	* Sleeve - Flashing indicator cable ..... up to Chassis No. 1 600 439	2	M 22
-	111 953 183	Relay 6 V - Flashing indicator 2X21 W ..... from Chassis No. 111 2799 843	1	M 37: 111, 112, 115, 116
-	113 953 183 B	Relay 12 V - Flashing indicator 2X18 W ..... up to Chassis No. 116 1021 300	1	M 610
		(up to Chassis No. 115 999 000 use 1 ground strap 211 971 119 A)		

Key No.	Part No.	Description	Quantity	Type and model
47	211 953 183 A	Relay 12 V - Flashing indicator 2X21 W ..... from Chassis No. 117 000 001 up to 118 1016 100 from Chassis No. 118 000 001 up to 118 1016 100 from Chassis No. 119 000 001 up to 110 3100 000  from Chassis No. 111 2000 001 up to 111 2799 842	1 1 1 1	M 610 113, 114, 117, 118, 151, 152 M 37: 113, 114, 117, 118, 151, 152; M 610 M 1/M 37: 113, 114, 117, 118; M 610
-	411 953 183	Relay 12 V - Flashing indicator 2X21 W ..... from Chassis No. 111 2000 001  from Chassis No. 111 2799 843	1 1	M 37: 113, 114, 117, 118, 151, 152 M 1/M 37: 113, 114, 117, 118; M 610
-	*111 953 185 B <i>SSD</i>	Relay 6 V - Flashing indicator 2X18 W ..... up to Chassis No. 4 846 835	1	
-	111 953 185 C	Relay 6 V - Flashing indicator 2X18 W ..... from Chassis No. 4 846 836 up to 117 999 000 from Chassis No. 118 000 001 up to 118 1016 100 (up to Chassis No. 115 999 000 use 1 ground strap 211 971 119 A)	1 1	111, 112, 115, 116
-	111 953 185 D	Relay 6 V - Flashing indicator 2X21 W ..... from Chassis No. 119 000 001 up to 111 2799 842	1	M 37: 111, 112, 115, 116
-	*111 953 193	Packing - Flashing indicator, front ..... up to Chassis No. 5 888 184 from Chassis No. 6 093 328 up to 115,651 940	2 2	M 34
48	111 953 193 D *	Packing - Flashing indicator, front ..... from Chassis No. 115 651 941 up to 119 1200 000 from Chassis No. 5 888 185 up to 119 1200 000	2 2	M 22, M 34
-	111 953 193 E	Packing - Flashing indicator, front ..... from Chassis No. 110 2000 001	2	
-	113 953 193 *	Packing - Flashing indicator, front ..... from Chassis No. 110 2000 001	2	M 23
-	111 953 197	Gasket - Screw, countersunk raised N 14 267 5 ...	2	
-	111 953 211	Special relay 6 V (for trailer operation) .....	x	
-	113 953 211	Special relay 12 V (for trailer operation) .....	x	
-	*211 953 215 B	Relay 6 V - Emergency light 4X18 W ..... up to Chassis No. 117 999 000 from Chassis No. 118 000 001 up to 118 1016 100 (use: 111 953 235 C)	x x	111, 112, 115, 116
-	*211 953 215 C	Relay 12 V - Emergency light 4X21 W ..... from Chassis No. 118 381 367 up to 118 1016 100 from Chassis No. 119 000 001 up to 110 3100 000  from Chassis No. 111 2000 001 up to 111 2799 842	1 1 1	M 23, M 601, M 602 113, 114, 117, 118, 151, 152, M 610 M 1: 113, 114, 117, 118, M 610

*LATE 68  
A-70*



Key No.	Part No.	Description	Quantity	Type and model
-	211 953 215 D	Relay 6 V - Emergency light 4x21 W ..... from Chassis No. 119 000 001 up to 111 2799 842	1	111, 112, 115, 116
-	111 953 225 B 65	* Relay 6 V - Emergency light 4x18 W ..... from Chassis No. 116 000 001 up to 117 999 000	1	M 22
-	111 953 227	* Relay 12 V - Emergency light 4x18 W ..... from Chassis No. 116 000 001 up to 116 1021 300	1	M 22/M 610
-	111 953 227 A	Relay 12 V 4x21 W - Flashing indicator/ ..... emergency light from Chassis No. 111 2000 001 from Chassis No. 111 2799 843	1 1	113, 114, 117, 118, 151, 152 M 1: 113, 114, 117, 118; M 610
-	111 953 227 B	Relay 6 V 4x21 W - Flashing indicator/ ..... emergency light from Chassis No. 111 2799 843	1	111, 112, 115, 116
49	*211 953 227 B 67 68	* Relay 12 V - Emergency light 4x21 W ..... from Chassis No. 117 000 001 up to 117 999 000 from Chassis No. 118 000 001 up to 118 381 366	1 1	M 22/M 610, M 611 M 23, M 601, M 602
-	N 13 978 1	* Tapping screw, fillister head B 4.8x55 ..... from Chassis No. 116 000 001 up to 117 999 000	1	M 22, M 611
-	N 13 952 1	* Tapping screw, fillister head B 4.8x45 ..... from Chassis No. 118 000 001 up to 118 381 366	1	M 23, M 601, M 602
50	N 13 971 1	* Tapping screw, fillister head B 4.8x22 ..... from Chassis No. 118 381 367 up to 118 1016 100 from Chassis No. 119 000 001 up to 110 3100 000 from Chassis No. 111 2000 001 up to 111 2799 842	1 1 1	M 23, M 601, M 602 111, 112, 115, 116; M 1
-	N 12 225 1	* Spring washer B 5 ..... from Chassis No. 116 000 001 up to 117 999 000	1	M 22, M 611
-	211 953 187	Relay 12 V - Flashing indicator 3x21 W ..... (for trailer operation)	x	
-	261 953 187 B	Relay 6 V - Flashing indicator 3x18 W ..... (for trailer operation) up to Chassis No. 118 1016 100	x	
-	211 953 231 D	Relay 12 V - Emergency light 6x21 W ..... (for trailer operation) (from Chassis No. 3 192 507 up to 3 856 471 Germany, from Chassis No. 3 192 507 up to 4 010 994: export markets, convert faillights to twin compartments for stop light and flashing indicators) (Use switch 211 953.235 A also)	x	

Key No.	Part No.	Description	Quantity	Type and model
-	111 919 209 A	Warning lamp - Flashing indicator from Chassis No. 112 2000 001	1	M 208
-	N 17 751 2	Bulb JG 12 V 1.2 W from Chassis No. 112 2000 001	1	M 208
-	261 945 061 C	Socket 7pole from Chassis No. 112 2000 001	1	M 208
-	111 953 235	* Switch - Emergency light from Chassis No. 116 000 001 up to 116 1021 300	1	M 22
-	111 941 515	* Escutcheon M 10X1 - Emergency light switch from Chassis No. 116 000 001 up to 116 1021 300	1	M 22
-	*111 953 235 A	* Switch - Emergency light from Chassis No. 117 000 001 up to 117 999 000	1	M 22, M 611
51	111 953 235 B	* Switch - Emergency light from Chassis No. 118 000 001 up to 118 381 366	1	M 23, M 601, M 602
-	*211 953 235 A	* Switch - Emergency light from Chassis No. 118 381 367 up to 118 1016 100 from Chassis No. 119 000 001	1 1	M 23, M 601, M 602
-	111 941 515 C	* Escutcheon M 12X1 - Emergency light switch from Chassis No. 117 000 001 up to 117 999 000	1	M 22, M 611
52	111 941 515 D	* Escutcheon M 14X1 - Emergency light switch from Chassis No. 118 000 001 up to 118 1016 100 from Chassis No. 119 000 001	1 1	M 23, M 601, M 602
-	111 953 241	* Spindle with knob - Emergency light switch from Chassis No. 116 000 001 up to 116 1021 300	1	M 22
-	*111 953 245 A	* Spindle with knob - Emergency light switch from Chassis No. 117 000 001 up to 117 999 000	1	M 22, M 611
-	111 953 245 B	Spindle with knob - Emergency light switch from Chassis No. 119 000 001 up to 110 3100 000 (and for service installation in vehicles without instrument panel cover)	1	
53	111 953 245 D	* Spindle with knob - Emergency light switch from Chassis No. 118 000 001 up to 110 3100 000	1	M 23, M 228, M 601, M 602
-	111 953 245 E	Spindle with knob - Emergency light switch from Chassis No. 111 2000 001	1	
-	111 953 245 G	Switch spindle with knob for rear fog lamp from Chassis No. 110 2000 001	X	

\*111 953 235 A  
SS 04  
111 953 235 E



Key No.	Part No.	Description	Quantity	Type and model
-	111 953 245 H	* Switch spindle with knob for rear fog lamp from Chassis No. 110 2000 001	x	M 228
-	111 959 631	Switch - Rear fog lamp from Chassis No. 110 2000 001	x	
-	113 953 245 <i>USA</i>	* Spindle with knob - Emergency light switch from Chassis No. 111 2000 001	1	151, 152; M 23, M 60/M 228, M 228, M 603
-	111 941 543 E	* Lens, red with symbol, for emergency light switch from Chassis No. 118 000 001 up to 111 3200 000	1	M 23: 113, 114, 117, 118, 151, 152
54	111 941 543 F	Lens, red without symbol, for emergency light switch from Chassis No. 118 000 001 up to 118 1016 100 from Chassis No. 119 000 001	1 1	M 601, M 602
-	113 941 543 C	Lens, red with symbol, for emergency light from Chassis No. 112 2000 001	1	M 23: 113, 114, 117, 118, 151, 152
-	111 953 255	* Lens, red with symbol, for emergency light switch from Chassis No. 116 000 001 up to 117 999 000	1	M 22, M 611
-	N 17 751 1	* Bulb JG 6 V 1.2 W from Chassis No. 116 000 001 up to 117 999 000 from Chassis No. 119 000 001	1 1	M 22 111, 112, 115, 116
55	N 17 751 2	* Bulb JG 12 V 1.2 W from Chassis No. 116 000 001 up to 117 999 000 from Chassis No. 118 000 001 up to 118 1016 100 from Chassis No. 119 000 001	1 1 1	M 22/M 610, M 611 M 23, M 601, M 602 113, 114, 117, 118, 151, 152
-	111 953 309	Lens - Side flashing indicator up to Chassis No. 115 651 940 up to Chassis No. 116 463 102	2 2	M 34 M 66



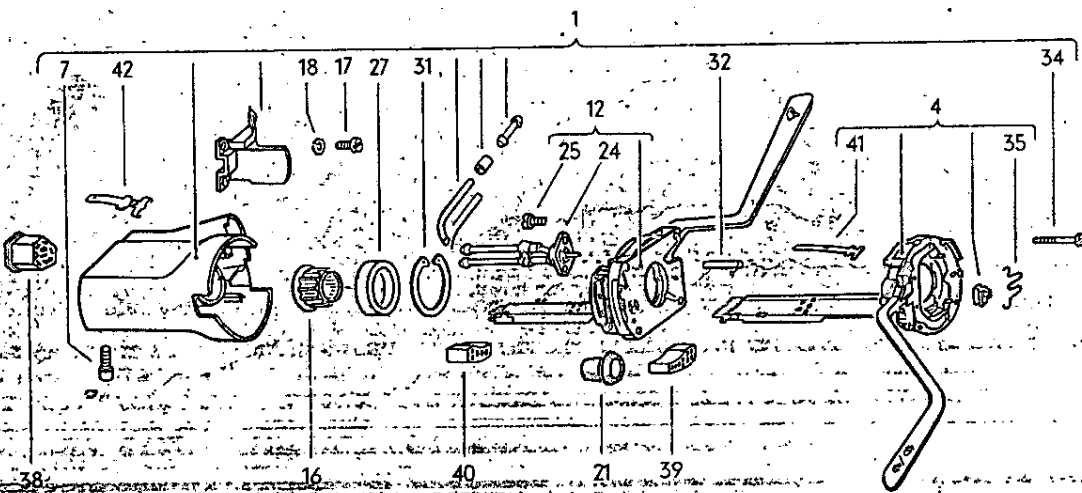
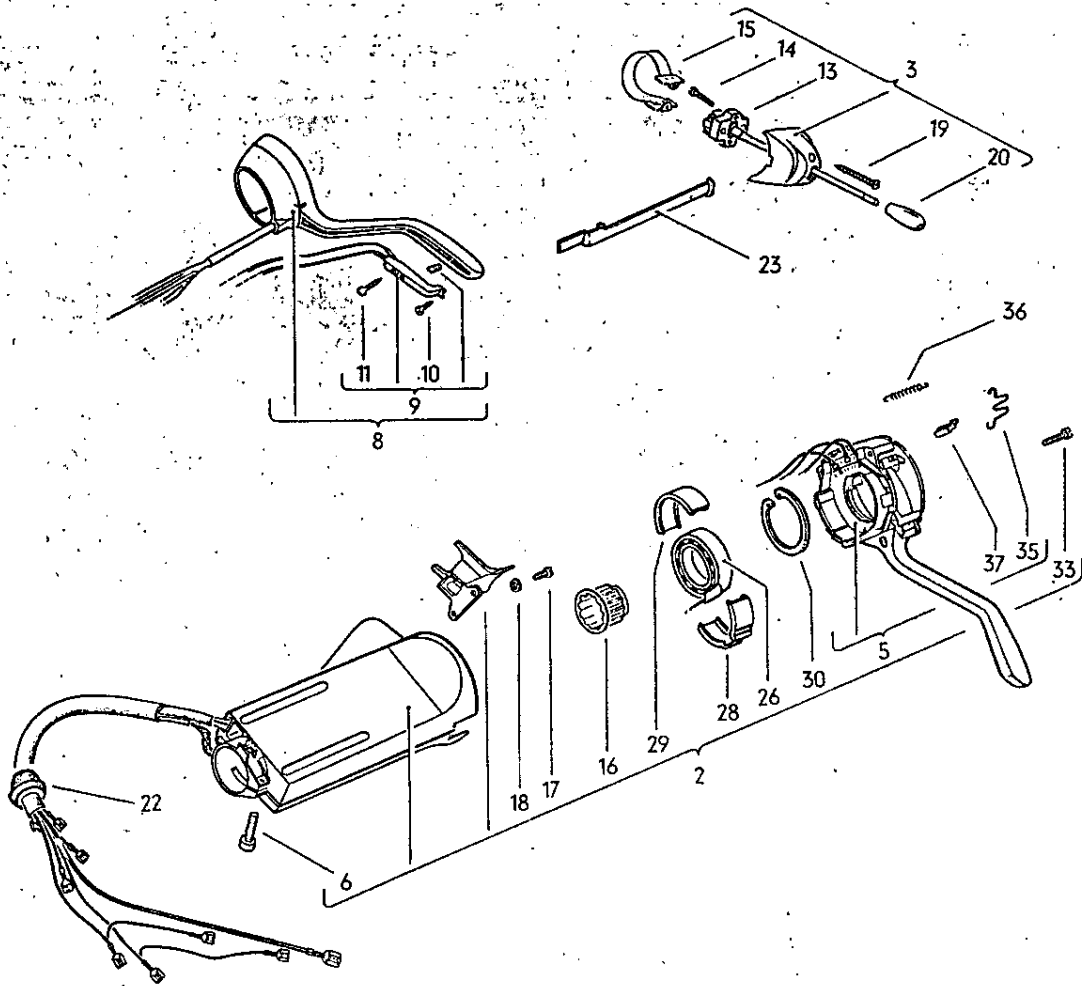

Key No.	Part No.	Description	Quantity	Type and model
<b>INDICATOR SWITCH</b>				
(2)	113 953 503 R	Indicator switch with steering lock and ignition/ starter switch without lock cylinder from Chassis No. 111 2000 001 up to 111 3200 000 from Chassis No. 112 2000 001	1 1	111, 112, 115, 116
1	113 953 503 AE	Steering column combination switch with steering lock and ignition-starter switch without lock cylinder from Chassis No. 112 2000 001	1	113, 114, 117, 118, 151, 152; M 1, M 108, M 110
(2)	311 953 503 Q	Indicator switch with steering lock and ignition/ starter switch without lock cylinder from Chassis No. 118 000 001 up to 119 1200 000	1	M 55 (Germany: standard equipment)
(2)	311 953 503 R	Indicator switch with ignition/starter switch ..... without lock cylinder from Chassis No. 118 000 001 up to 119 1200 000 from Chassis No. 110 2000 001 up to 110 3100 000	1 1	M 248
2	311 953 503 AF	Indicator switch with steering lock and ignition- starter switch without lock cylinder from Chassis No. 110 2000 001 up to 110 3100 000	1	
3	111 953 511 A	Switch - Direction indicator ..... from Chassis No. 1 - 397 023 up to 2 528 667 up to Chassis No. 3 192 506 10/52 - 7/60 471 stone beige	1 1	113, 114, 117, 118, 151, 152 111, 112, 115, 116
(8)	113 953 511 A	Direction indicator switch - Self-cancelling ..... from Chassis No. 2 528 668 up to 3 192 506	1	113, 114, 117, 118, 151, 152
(8)	111 953 513 A *	Flashing indicator switch - Self-cancelling ..... Germany only: from Chassis No. 3 192 507 up to 3 856 471 Export only: from Chassis No. 3 192 507 up to 4 010 994 8/60 - 7/61 041 black up to Chassis No. 2 528 667 8/57 - 7/59 471 stone beige	1 1	111, 112, 115, 116 M 22
(8)	111 953 513 B	Flashing indicator switch - Self-cancelling ..... Germany only: from Chassis No. 3 856 472 up to 116 1021 300 Export only: from Chassis No. 4 010 995 up to 116 1021 300 3/61 - 7/66 466 silver beige	1	111, 112, 115, 116
(5)	111 953 513 C	Indicator switch-upper part ..... from Chassis No. 111 2000 001 up to 111 3200 000 from Chassis No. 112 2000 001	1 1	111, 112, 115, 116
4	111 953 513 E	Indicator switch-upper part ..... from Chassis No. 112 2000 001	1	113, 114, 117, 118, 151, 152; M 1, M 108, M 110



Key No.	Part No.	Description	Quantity	Type and model
5	311 953 513 B	Indicator switch-upper part ..... from Chassis No. 118 000 001 up to 110 3100 000	1	
6	N 14 709 1	Screw, cheese head M 8×22 ..... from Chassis No. 118 000 001 up to 111 3200 000 from Chassis No. 112 2000 001	1 1	111, 112, 115, 116
7	N 14 707 2	Screw, cheese head M 8×15 ..... from Chassis No. 112 2000 001	1	113, 114, 117, 118, 151, 152; M 1, M 108, M 110
(8)	113 953 517	* Flashing indicator switch – Self-cancelling ..... from Chassis No. 2 528 668 up to 3 192 506	1	M 22: 113, 114, 117, 118, 151, 152
(8)	113 953 517 B	Flashing indicator switch – Self-cancelling ..... Germany only: from Chassis No. 3 192 507 up to 4 010 994 Export only: from Chassis No. 3 192 507 up to 4 010 994 468 sand stone	1	113, 114, 117, 118, 151, 152
	8/60 - 7/61			
(8)	141 953 517 C	Flashing indicator switch – Self-cancelling ..... Germany only: from Chassis No. 3 856 472 up to 115 999 000 Export only: from Chassis No. 4 010 995 up to 115 999 000 466 silver beige	1	113, 114, 117, 118, 151, 152
	5/61 - 7/65			
8	141 953 517 F	Flashing indicator switch – Self-cancelling ..... from Chassis No. 116 000 001 up to 116 1021 300 from Chassis No. 117 000 001 up to 117 999 000 043 grey-black	1 1	113, 114, 117, 118, 151, 152
	8/65 - 7/67			
(9)	111 998 111	Headlamp flasher press button for service ..... installation from Chassis No. 2 528 668 up to 115 999 000	1	113, 114, 117, 118, 151, 152
9	311 953 529	Button – Flashing indicator ..... from Chassis No. 116 000 001 up to 116 1021 300 from Chassis No. 117 000 001 up to 117 999 000	1 1	113, 114, 117, 118, 151, 152
10	N 11 362 1	Tapping screw, cheese head BZ 2.2×6.5 ..... from Chassis No. 116 000 001 up to 116 1021 300 from Chassis No. 117 000 001 up to 117 999 000	1 1	113, 114, 117, 118, 151, 152
11	N 11 363 1	Tapping screw, cheese head BZ 2.2×11 ..... from Chassis No. 116 000 001 up to 116 1021 300 from Chassis No. 117 000 001 up to 117 999 000	1 1	113, 114, 117, 118, 151, 152
12	111 953 519 E	Switch – Windshield wipers and washer ..... from Chassis No. 112 2000 001	1	113, 114, 117, 118, 151, 152; M 1, M 108, M 110
13	111 953 521	Switch – Direction indicator without housing ..... up to Chassis No. 2 528 667 from Chassis No. 2 528 668 up to 3 192 506	1 1	111, 112, 115, 116

Key No.	Part No.	Description	Quantity	Type and model
14	N 11 230 1	Screw, button head BM 3×12 up to Chassis No. 2 528 667 from Chassis No. 2 528 668 up to 3 192 506	2 2	111, 112, 115, 116
(14)	111 953 523	* Screw, fillister head M 3×5 – Self-cancelling switch for flashing indicator up to Chassis No. 2 528 667 from Chassis No. 3 192 507 up to 116 1021 300	2 2	M 22 111, 112, 115, 116
15	111 953 531	Clamp – Direction indicator switch up to Chassis No. 2 528 667 from Chassis No. 2 528 668 up to 3 192 506	1 1	111, 112, 115, 116
16	111 953 535 D	Contact ring – Flashing indicator switch from Chassis No. 118 000 001	1	
17	N 10 811 1	Screw, fillister head AM 5×8 from Chassis No. 118 000 001	2	
18	N 12 005 1	Lock washer B 5 from Chassis No. 118 000 001	2	
19	111 953 539	Screw, button head – Clamp up to Chassis No. 2 528 667 from Chassis No. 2 528 668 up to 3 192 506	2 2	111, 112, 115, 116
(20)	111 953 541	Knob black – Direction indicator switch from Chassis No. 1 – 397 023 up to 6 502 399	1	111, 112, 115, 116
20	113 953 541	Knob – Direction indicator switch from Chassis No. 1 – 397 023 up to 2 528 667 from Chassis No. 5 677 119 up to 116 1021 300 466 silberbeige	1 1	113, 114, 117, 118, 151, 152 111, 112, 115, 116
	10/52 - 7/64			
21	311 971 907	Cable sleeve – Flashing indicator cable from Chassis No. 112 2000 001	1	113, 114, 117, 118, 151, 152; M 1, M 108, M 110
22	*111 953 547	Cable sleeve – Flashing indicator cable up to Chassis No. 111 3200 000 from Chassis No. 112 2000 001	1 1	111, 112, 115, 116
(22)	N 20 091 1	Cable sleeve – Direction indicator cable up to Chassis No. 1 – 929 745	1	
(22)	111 953 547 A	Cable sleeve – Direction indicator cable from Chassis No. 1 – 929 746 up to 3 192 506	1	
23	111 953 549 A	* Cover plate – Flashing indicator cables (on steering column tube) up to Chassis No. 2 528 667 from Chassis No. 2 528 668 up to 115 999 000	1 1	M 22 111, 112, 115, 116



Key No.	Part No.	Description	Quantity	Type and model
24	111 953 553	Valve for windshield washer in combination switch from Chassis No. 112 2000 001	1	113, 114, 117, 118, 151, 152; M 1, M 108, M 110
25	N 10 802 2	Screw, fillister head AM 3×6 from Chassis No. 112 2000 001	2	113, 114, 117, 118, 151, 152; M 1, M 108, M 110
26	111 953 559	Ball bearing – Indicator switch from Chassis No. 118 000 001 up to 110 3100 000	1	
27	111 953 559 A	Ball bearing – Indicator switch from Chassis No. 111 2000 001	1	
28	111 953 561	Insulating half ring, left – Ball bearing from Chassis No. 118 000 001 up to 110 3100 000	1	
29	111 953 562	Insulating half ring, right – Ball bearing from Chassis No. 118 000 001 up to 110 3100 000	1	
30	111 953 563	Circlip – Ball bearing from Chassis No. 118 000 001 up to 110 3100 000	1	
31	111 953 563 A	Circlip – Ball bearing from Chassis No. 111 2000 001	1	
(32)	111 953 572	Spacer bush – Indicator switch upper part from Chassis No. 118 000 001 up to 111 3200 000 from Chassis No. 112 2000 001	2 2	111, 112, 115, 116
32	111 953 572 A	Spacer bush – Indicator switch upper part from Chassis No. 112 2000 001	4	113, 114, 117, 118, 151, 152; M 1, M 108, M 110
33	111 953 573	Bolt – Indicator switch-upper part from Chassis No. 118 000 001 up to 111 3200 000 from Chassis No. 112 2000 001	4 4	111, 112, 115, 116
34	111 953 573 A	Screw – Indicator switch-upper part from Chassis No. 112 2000 001	4	113, 114, 117, 118, 151, 152; M 1, M 108, M 110
35	111 953 575	Spring – Indicator switch-upper part (SWF) from Chassis No. 118 000 001	1	
36	111 953 575 A	Spring – Indicator switch-upper part (⊗) from Chassis No. 118 000 001	1	
37	111 953 577	Friction piece – Spring from Chassis No. 118 000 001 up to 111 3200 000 from Chassis No. 112 2000 001	2 2	111, 112, 115, 116

Key No.	Part No.	Description	Quantity	Type and model
38	111 953 631	Terminal pin housing for ignition starter switch harness from Chassis No. 112 2000 001	1	113, 114, 117, 118, 151, 152; M 1, M 108, M 110
39	111 953 633	Terminal pin housing – Flashing indicator cables from Chassis No. 112 2000 001	1	113, 114, 117, 118, 151, 152; M 1, M 108, M 110
40	111 953 635	Terminal pin housing – Wiper motor cables from Chassis No. 112 2000 001	1	113, 114, 117, 118, 151, 152; M 1, M 108, M 110
41	111 971 983	Flat terminal 2.8×0.8 from Chassis No. 112 2000 001	x	113, 114, 117, 118, 151, 152; M 1, M 108, M 110
42	111 971 987	Flat terminal 6.3×0.8 from Chassis No. 112 2000 001	x	113, 114, 117, 118, 151, 152; M 1, M 108, M 110

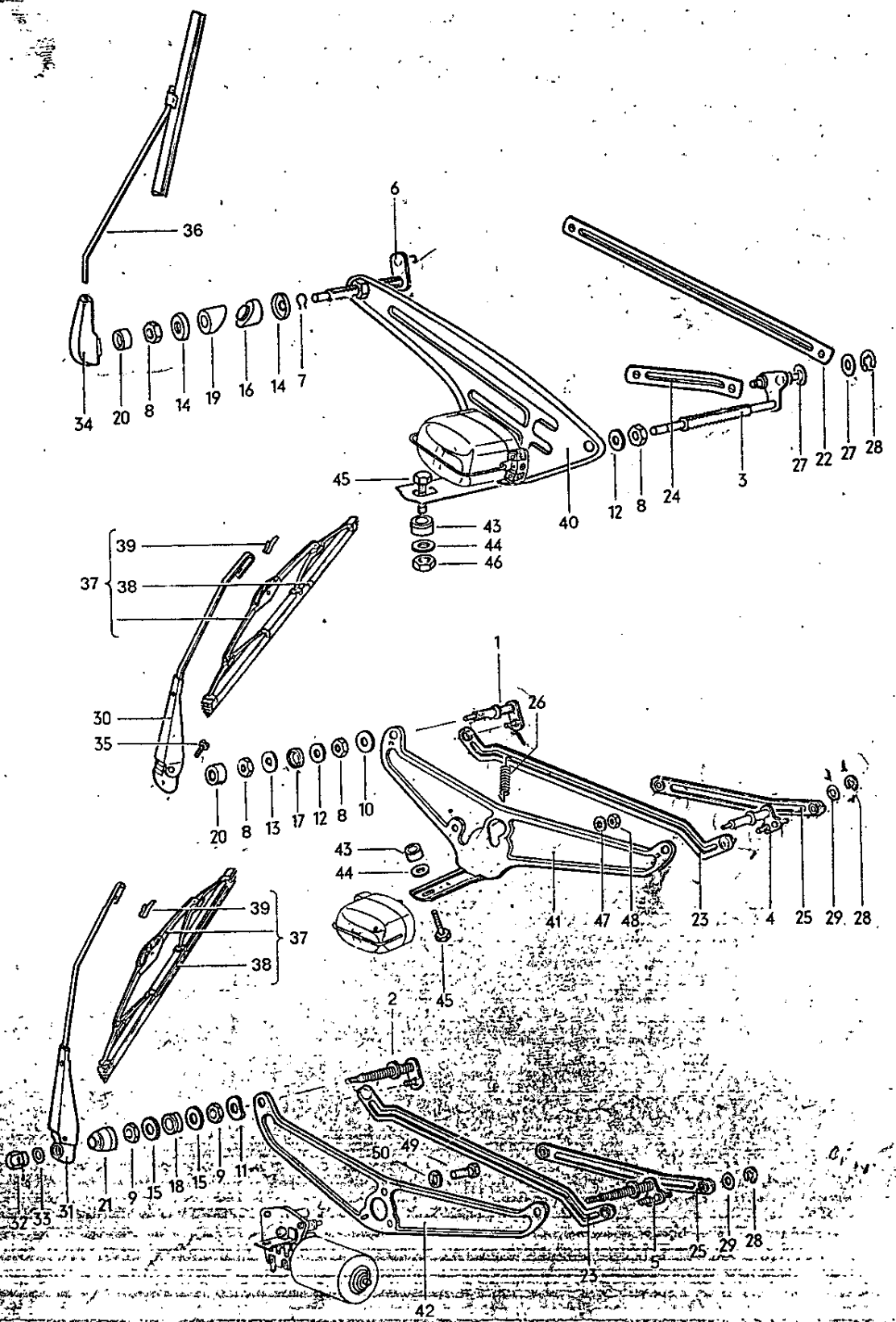

Key No.	Part No.	Description	Quantity	Type and model
<b>WINDSHIELD WIPER</b>				
(1)	*111 955 215 B	Windshield wiper shaft with crank left: from Chassis No. 1 600 440 up to 6 502 399 right: from Chassis No. 115 000 001 up to 117 999 000 from Chassis No. 118 000 001 up to 119 1200 000	1 1 1	111, 112, 115, 116
1	*111 955 215 C USA	Windshield wiper shaft, right, with crank from Chassis No. 118 000 001 up to 119 1200 000	1	113, 114, 117, 118, 151, 152
2	*111 955 215 D	Windshield wiper shaft, right, with crank from Chassis No. 110 2000 001	1	113, 114, 117, 118, 151, 152
(2)	*111 955 215 H	Windshield wiper shaft, right, with crank from Chassis No. 110 2000 001	1	111, 112, 115, 116
(1)	111 955 215 J	Windshield wiper shaft, right, with crank from Chassis No. 118 000 001 up to 119 1200 000 (for installation in bodies with 15 mm dia. opening only)	1	113, 114, 117, 118, 151, 152
3	113 955 215	Windshield wiper shaft with bearing up to Chassis No. 1 600 439	1	
(2)	*111 955 216 B	Windshield wiper shaft, right, with crank from Chassis No. 1 600 440 up to 6 502 399	1	
(4)	*111 955 216 C USA	Windshield wiper shaft, left, with crank from Chassis No. 115 000 001 up to 117 999 000 from Chassis No. 118 000 001 up to 119 1200 000	1 1	111, 112, 115, 116
4	*111 955 216 D USA	Windshield wiper shaft, left, with crank from Chassis No. 118 000 001 up to 119 1200 000	1	113, 114, 117, 118, 151, 152
5	*111 955 216 E	Windshield wiper shaft, left, with crank from Chassis No. 110 2000 001	1	113, 114, 117, 118, 151, 152
(5)	*111 955 216 H	Windshield wiper shaft, left, with crank from Chassis No. 110 2000 001	1	111, 112, 115, 116
(4)	111 955 216 J	Windshield wiper shaft, left, with crank from Chassis No. 118 000 001 up to 119 1200 000 (for installation in bodies with 15 mm dia. opening only)	1	113, 114, 117, 118, 151, 152
6	113 955 216	Windshield wiper shaft with bearing up to Chassis No. 1 600 439	1	



Key No.	Part No.	Description	Quantity	Type and model
7	111 955 241	Circlip ..... up to Chassis No. 1 600 439	2	
8	*113 955 243 A	Nut, hex. chromium plated ..... up to Chassis No. 119 1200 000	4	
9	*311 955 243 A	Nut, hex. M 12X1 chromium plated ..... from Chassis No. 110 2000 001	4	
10	*N 12 231 1	Spring washer B 10 .....	2	
11	*N 12 232 1	Spring washer B 12 ..... from Chassis No. 110 2000 001	2	113, 114, 117, 118, 151, 152
12	*111 955 245	Washer ..... up to Chassis No. 119 1200 000	2	
13	*111 955 255 A	Washer, chromium plated ..... from Chassis No. 1 600 440 up to 119 1200 000	2	
14	113 955 255 A	Washer, chromium plated ..... up to Chassis No. 1 600 439	4	
15	*311 955 255	Washer, chromium plated ..... from Chassis No. 110 2000 001	2	
16	111 955 261	Ferrule - Windshield wiper bearing, inner ..... up to Chassis No. 1 600 439	2	
(16)	*111 955 261 A	Ferrule - Windshield wiper bearing, inner ..... from Chassis No. 1 600 440 up to 6 502 399	2	
17	*111 955 261 B	Ferrule - Windshield wiper bearing, inner ..... from Chassis No. 115 000 001 up to 119 1200 000	2	
18	*311 955 261 A	Ferrule - Windshield wiper bearing, inner ..... from Chassis No. 110 2000 001	2	
19	111 955 265	Ferrule - Windshield wiper bearing, outer ..... up to Chassis No. 1 600 439	2	
(19)	*111 955 265 A	Ferrule - Windshield wiper bearing, outer ..... from Chassis No. 1 600 440 up to 6 502 399	2	
20	*113 955 275 B	Bearing cover ..... up to Chassis No. 119 1200 000	2	
21	*211 955 275 A	Bearing cover ..... from Chassis No. 110 2000 001	2	
22	111 955 305 A	Connecting rod - Windshield wiper ..... up to Chassis No. 1 600 439	1	

Key No.	Part No.	Description	Quantity	Type and model
(22)	111 955 305 B	Connecting rod - Windshield wiper from Chassis No. 1 600 440 up to 6 502 399	1	
(22)	111 955 305 C	Connecting rod - Windshield wiper from Chassis No. 115 000 001 up to 117 999 000 from Chassis No. 118 000 001	1 1	111, 112, 115, 116
23	111 955 305 D	Connecting rod - Windshield wiper (for 7 mm pin) from Chassis No. 118 000 001	1	113, 114, 117, 118, 151, 152
24	111 955 325	Connecting link - Windshield wiper up to Chassis No. 1 600 439	1	
(24)	111 955 325 A	Connecting link - Windshield wiper from Chassis No. 1 600 440 up to 6 502 399	1	
(24)	111 955 325 B	Connecting link - Windshield wiper from Chassis No. 115 000 001 up to 117 999 000 from Chassis No. 118 000 001	1 1	111, 112, 115, 116
25	111 955 325 C	Connecting link - Windshield wiper (for 7 mm pin) from Chassis No. 118 000 001	1	113, 114, 117, 118, 151, 152
(26)	111 955 339	Retaining spring - Connecting rod from Chassis No. 1 600 440 up to 6 502 399	1	
26	111 955 339 A	Retaining spring - Connecting rod from Chassis No. 115 000 001 up to 117 999 000 from Chassis No. 118 000 001	1 1	111, 112, 115, 116
27	111 955 341	Washer - Crank pin up to Chassis No. 1 600 439	8	
(28)	*111 955 346 A	Lockwasher - Crank pin up to Chassis No. 117 999 000 from Chassis No. 118 000 001	4 4	111, 112, 115, 116
28	*N 12-436.2	Lock washer 6 from Chassis No. 118 000 001	4	113, 114, 117, 118, 151, 152
(29)	*111 955 349	Spring washer from Chassis No. 1 600 440 up to 117 999 000 from Chassis No. 118 000 001	4 4	111, 112, 115, 116
29	*111 805 167 A	Spring washer 7.4 galvanized from Chassis No. 118 000 001	4	113, 114, 117, 118, 151
(30)	111 955 407	Bracket with windshield wiper arm from Chassis No. 2 626 976 up to 6 502 399	2	111, 112, 115, 116

Key No.	Part No.	Description	Quantity	Type and model
30	111 955 407 D	Bracket with windshield wiper arm, left from Chassis No. 118 000 001 up to 119 1200 000 from Chassis No. 110 2000 001	1 1	111, 112, 115, 116
31	111 955 407 E	Bracket with windshield wiper arm, left (aluminium colored) from Chassis No. 110 2000 001	1	113, 114, 117, 118
(31)	*113 955 407 B	Bracket with windshield wiper arm (aluminium colored) from Chassis No. 1 600 440 up to 6 502 399	2	113, 114, 117, 118, 151, 152
(31)	113 955 407 D	Bracket with windshield wiper arm (aluminium colored) from Chassis No. 115 000 001 up to 117 999 000 left: from Chassis No. 158 000 001 up to 159 1200 000	2 1	151, 152
(31)	113 955 407 F	Bracket with windshield wiper arm, left (aluminium colored) from Chassis No. 150 2000 001	1	151, 152
(31)	111 955 408	Bracket with windshield wiper arm, right from Chassis No. 118 000 001 up to 119 1200 000 from Chassis No. 110 2000 001	1 1	111, 112, 115, 116
(31)	111 955 408 A	Bracket with windshield wiper arm, right (aluminium colored) from Chassis No. 110 2000 001	1	113, 114, 117, 118, 151, 152
32	*211 955 417 A	Cap nut - Bracket from Chassis No. 110 2000 001	2	
33	*N 12 227 3	Spring washer A 6 from Chassis No. 110 2000 001	2	113, 114, 117, 118, 151, 152
(31)	*113 955 408 B	Bracket with windshield wiper arm, right (aluminium colored) (converted windshield wipers) up to Chassis No. 1 600 439	1	
(34)	111 955 411 A	Bracket - Windshield wiper arm from Chassis No. 1 600 440 up to 2 626 975	2	111, 112, 115, 116
	111 998 151	Windshield wipers (aluminium colored) for service installation up to Chassis No. 1 600 439	1	
	113 955 411 A	Bracket - Windshield wiper arm (aluminium colored) from Chassis No. 1 - 575 415 up to 2 477 021	2	113, 114, 117, 118, 151, 152
	113 955 415 A	Securing screw - Bracket from Chassis No. 115 000 001	2	

Key No.	Part No.	Description	Quantity	Type and model
(36)	111 955 421 A	Arm - Windshield wiper, with blade from Chassis No. 1 600 440 up to 2 626 975	2	111, 112, 115, 116
(36)	113 955 421 A	Arm - Windshield wiper, left, with blade (aluminium colored) from Chassis No. 1 - 575 415 up to 1 600 439	1	113, 114, 117, 118, 151, 152
(36)	113 955 421 B	Arm - Windshield wiper, with blade (aluminium colored) from Chassis No. 1 600 440 up to 2 477 021	2	113, 114, 117, 118, 151, 152
36	113 955 422 A	Arm - Windshield wiper, right, with blade (aluminium colored) from Chassis No. 1 - 575 415 up to 1 600 439	1	113, 114, 117, 118, 151, 152
(37)	111 955 425	Blade - Windshield wiper from Chassis No. 2 626 976 up to 6 502 399	2	111, 112, 115, 116
37	111 955 425 B SS BY	Blade - Windshield wiper (aluminium colored) from Chassis No. 118 000 001	2	
-	111 955 425 C *	Blade - Windshield wiper (only for USA) from Chassis No. 111 2432 001	2	113, 117, 151; M 108, M 110
(37)	*113 955 425 B	Blade - Windshield wiper (aluminium colored) from Chassis No. 2 477 022 up to 6 502 399	2	113, 114, 117, 118, 151, 152
(37)	113 955 425 D SS BY 111 955 425 B	Blade - Windshield wiper (aluminium colored) from Chassis No. 115 000 001 up to 117 999 000	2	SS BY 111 955 425 C
(37)	113 955 427	Windshield wiper blade, sprung up to Chassis No. 6 502 399	2	113, 114, 117, 118, 151, 152
38	111 955 429	Rubber - Windshield wiper blade 111 955 425 B from Chassis No. 118 000 001	2	113, 114, 117, 118, 151, 152
-	111 955 429 A *	Rubber - Windshield wiper blade (only for USA) from Chassis No. 111 2432 001	2	113, 117, 151; M 108, M 110
(38)	141 955 429	Rubber 235 mm - 9 1/4 in. Windshield wiper blade 113 955 427 up to Chassis No. 6 502 399	2	113, 114, 117, 118, 151, 152
(38)	113 955 429	Rubber Windshield wiper blade 113 955 425 D from Chassis No. 115 000 001 up to 117 999 000	2	
39	113 955 433	Retaining spring - Wiper blade 111 955 425 B/113 955 425 D	X	

Key No.	Part No.	Description	Quantity	Type and model
40	111 955 605	Frame - Windshield wiper ..... up to Chassis No. 1 600 439	1	
(40)	111 955 605 A	Frame - Windshield wiper ..... from Chassis No. 1 600 440 up to 6 502 399	1	
(40)	111 955 605 B	Frame - Windshield wiper ..... from Chassis No. 115 000 001 up to 117 999 000	1	
41	111 955 605 C	Frame - Windshield wiper ..... from Chassis No. 118 000 001 up to 119 1200 000	1	
(41)	111 955 605 D	Frame - Windshield wiper ..... from Chassis No. 110 2000 001	1	111, 112, 115, 116
42	113 955 611 B	Frame - Windshield wiper ..... from Chassis No. 110 2000 001	1	113, 114, 117, 118, 151, 152; M 1
43	111 955 641	Spacer .....	1	
44	N 11 695 2	Washer 6.1 .....	1	
45	N 10 216 8	Bolt, hex. head M 6×18 .....	1	
(44)	N 12 127 2	Shake-proof washer A 6.4 ..... up to Chassis No. 6 502 399	1	
46	N 11 006 2	Nut, hex. M 6 ..... up to Chassis No. 6 502 399	1	
47	N 12 225 1	Spring washer-B 5 .....	1	
48	N 11 005 2	Nut, hex. M 5 .....	1	
49	N 10 212 3	Bolt, hex. head M 6×12 .....	3	
50	N 12 226 2	Spring washer B 6 .....	3	



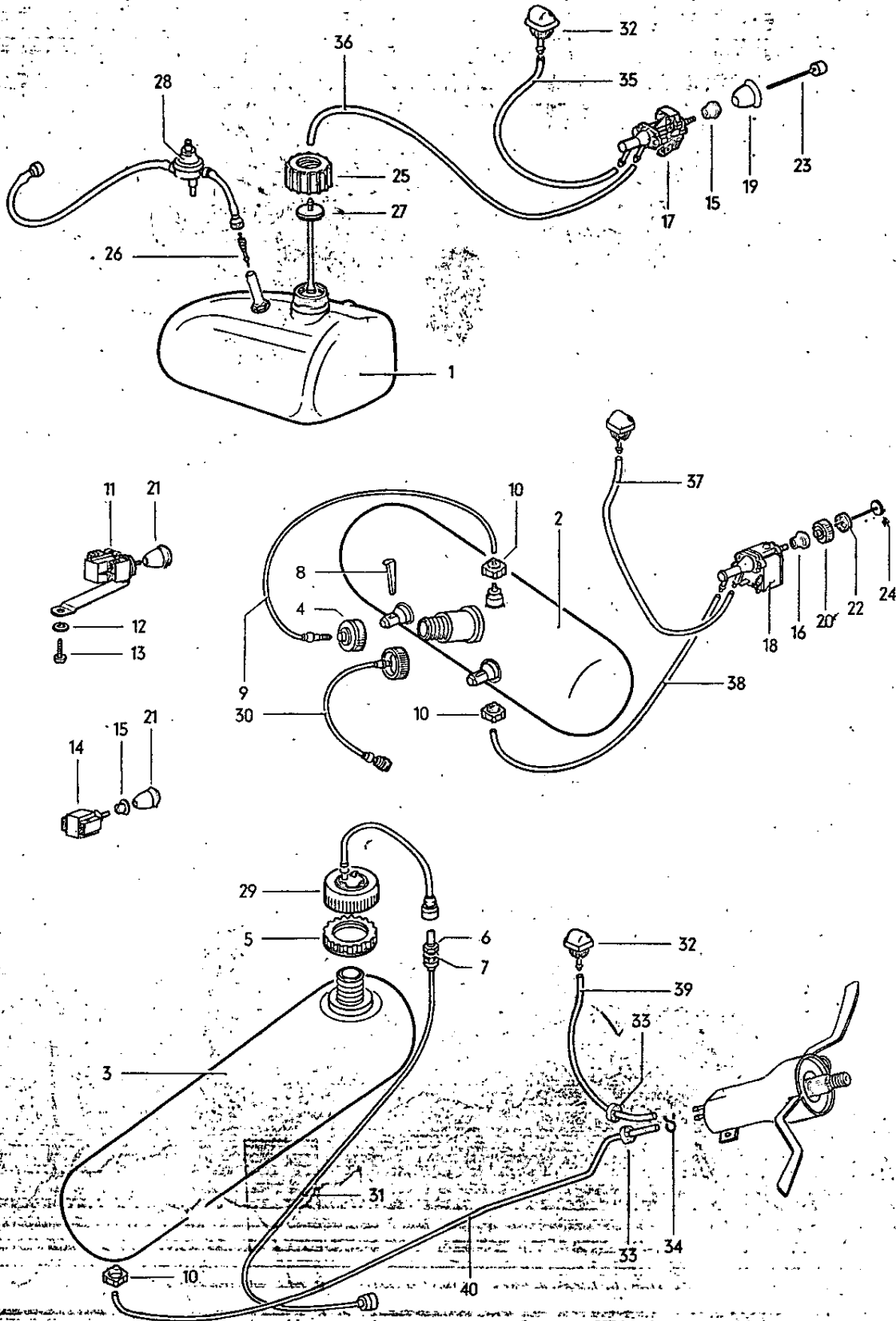

Key No.	Part No.	Description	Quantity	Type and model
<b>WINDSHIELD WASHER UNIT</b>				
-	113 955 081 A	Washer unit, pneumatic (without twin jets) up to Chassis No. 4 010 994	1	
(1)	111 955 941	Container - Washer unit up to Chassis No. 3 192 506	1	
(1)	113 955 941 A	Container - Washer unit (pneumatic) up to Chassis No. 4 010 994	1	
1	111 955 945 A	Container - Washer unit from Chassis No. 3 192 507 up to 4 010 994 (pneumatic) from Chassis No. 4 010 995 up to 117 999 000 use: from Chassis No. 3 192 507 up to 4 010 994 141 955 517, 113 955 541 B/549, 111 955 947 A/977 A	1	
2	111 955 453	Container - Washer unit from Chassis No. 118 000 001 up to 110 3100 000 from Chassis No. 111 2000 001	1 1	M 617 111, 112, 115, 116; M 1, M 62
		<i>Still in stock</i>		
		<i>USA SS BY 1119SS452B</i>		
(2)	111 955 453 A	Container - Washer unit from Chassis No. 118 000 001 up to 110 3100 000	1	
3	111 955 453 B	Container - Washer unit from Chassis No. 111 2000 001	1	113, 114, 117, 118, 151, 152
4	111 955 455	Cap - Container from Chassis No. 118 000 001 up to 110 3100 000	1	
5	311 955 461	Nut - Container from Chassis No. 111 2000 001	1	113, 114, 117, 118, 151, 152
6	311 955 459	Nut, hex. - Valve from Chassis No. 111 2000 001	1	113, 114, 117, 118, 151, 152
7	N 12 241 2	Spring washer B.8X15 from Chassis No. 111 2000 001	1	113, 114, 117, 118, 151, 152
8	111 955 467	Retaining wedges - Container from Chassis No. 118 000 001 up to 110 3100 000 from Chassis No. 111 2000 001	2 2	111, 112, 115, 116; M 1



Key No.	Part No.	Description	Quantity	Type and model
9	111 955 469	Valve with hose - Container from Chassis No. 118 000 001 up to 110 3100 000	1	
10	113 955 481	Securing nut - Hose from Chassis No. 118 000 001	2	
11	113 955 511 A	Push-pull type switch - Windshield wiper from Chassis No. 1 - 397 023 up to 1 600 439	1	
12	N 11 523 3	Washer A 5.3	1	
13	N 10 810 1	Screw, fillister head AM 5x6	1	
14	113 955 511 B	Push-pull type switch - Windshield wiper from Chassis No. 1 600 440 up to 3 192 506	1	
15	111 941 515	Escutcheon for push-pull type switch from Chassis No. 1 600 440 up to 117 999 000	1	
16	111 941 515 D	Escutcheon - Switch rotary from Chassis No. 118 000 001 up to 111 3200 000 from Chassis No. 112 2000 001	1	111, 112, 115, 116
(17)	113 955 515	Switch rotary - Pump for washer unit from Chassis No. 3 192 507 up to 4 010 994	1	
17	141 955 517	Switch rotary - Washer unit up to Chassis No. 117 999 000	1	
18	141 955 517 A	Rotary switch - Windshield wiper from Chassis No. 118 000 001 up to 111 3200 000 from Chassis No. 112 2000 001	1	111, 112, 115, 116
-	113 955 521	Valve body - Switch 113 955 517 up to Chassis No. 6 502 399	1	
-	111 955 531	Interval relay from Chassis No. 112 2000 001	1	M 652
19	111 955 541 B	Knob - Push-pull type switch, black 113 955 517/111 955 517 A up to Chassis No. 5 677 118	1	111, 112, 115, 116
(19)	113 955 541 B	Knob - Push-pull type switch, 113 955 517/111 955 517 A up to Chassis No. 116 1021 300 567 ivory 466 silver beige	1	
(20)	111 955 541 C	Knob - Switch rotary from Chassis No. 117 000 001 up to 117 999 000 043 grey-black	1	

Key No.	Part No.	Description	Quantity	Type and model
20	111 941 541 F	Knob - Rotary switch ..... from Chassis No. 118 000 001 up to 111 3200 000 from Chassis No. 112 2000 001	1 1	111, 112, 115, 116
21	113 941 541	Knob - Push-pull type switch ..... up to Chassis No. 4 010 994 567 ivory 466 silver beige	1 1	113, 114, 117, 118, 151, 152 111, 112, 115, 116
(20)	*113 941 541 B * <i>USA</i> <i>68-69-70</i>	Knob - Switch rotary ..... from Chassis No. 118 000 001 up to 118 1016 100 from Chassis No. 119 000 001 up to 110 3100 000 from Chassis No. 111 2000 001 up to 111 3200 000	1 1 1	<i>use with 413 955 549A</i> M 23 M 601, M 602 M 228 151, 152; M 228
22	111 941 547	Ring - Knob ..... from Chassis No. 118 000 001 up to 111 3200 000 from Chassis No. 112 2000 001	1 1	111, 112, 115, 116
23	111 955 549	Operating button, black - Windshield washer .... (pneumatic) up to Chassis No. 5 677 118	1	111, 112, 115, 116
(24)	111 955 549 L * <i>SS</i> <i>by</i> <i>113955549A</i>	Operating button - Windshield washer ..... (pneumatic) from Chassis No. 118 000 001 up to 118 1016 100 from Chassis No. 118 000 001 up to 119 1200 000 from Chassis No. 110 2000 001 up to 110 3100 000	1 1 1	M 601, M 602 M 23 M 228 M 228, M 603
(24)	113 955 549 <i>8/61 - 7/63</i> <i>8/63 - 7/66</i>	Operating button - Windshield washer ..... (pneumatic) up to Chassis No. 116 1021 300 567 ivory 466 silver beige	1	113, 114, 117, 118, 151, 152
(24)	*113 955 549 A *	Operating button - Windshield washer ..... (pneumatic) from Chassis No. 111-2000 001 up to 111 3200 000	1	151, 152; M 228, M 603
(24)	113 955 549 B	Operating button - Windshield washer ..... (pneumatic) from Chassis No. 117 000 001 up to 117 999 000	1	
24	411 955 549 B	Operating button - Windshield washer ..... (pneumatic) from Chassis No. 118 000 001 up to 110 3100 000 from Chassis No. 111 2000 001 up to 111 3200 000 from Chassis No. 112 2000 001 (up to Chassis No. 118 1016 100 shorten to 45 mm 1 <sup>25</sup> / <sub>32</sub> in.)	1 1 1	111-118 111, 112, 115, 116
25	111 955 947 A	Screw cap - Container ..... 113 955 941 A/111 955 945 A up to Chassis No. 117 999 000	1	
-	113 955 947	Filler cap - Container 113 955 941 .....	1	

Key No.	Part No.	Description	Quantity	Type and model
-	111 955 949	Bracket - Water container 113 955 941 A	1	
26	111 955 951	Valve unit - Container (Washer unit, pneumatic)	1	
-	N 20 301 1	Hose 4x1, 1600 mm - 63 in. - Washer unit up to Chassis No. 4 010 994	x	
-	113 955 975	T-valve - Washer unit up to Chassis No. 4 010 994	1	
27	111 955 977 A	Sealing disc - Fluid container 111 955 945 A from Chassis No. 4 010 995 up to 117 999 000	1	
28	111 955 979 C	Hose with valve between spare wheel and water container up to Chassis No. 117.999 000	1	
29	113 955 979	Hose with valve from Chassis No. 111 2000 001	1	113, 114, 117, 118, 151, 152
30	311 955 979 B	Hose with valve and cap between spare wheel and washer container from Chassis No. 118 000 001 up to 110 3100 000 from Chassis No. 111 2000 001	1 1	M 62, M 617 111, 112, 115, 116; M 1
31	411 955 983 SSby 411955983R	Hose with valve from spare wheel to water container bracket from Chassis No. 111 2000 001	1	113, 114, 117, 118, 151, 152
-	113 955 987	Cover - Twin jets 113 955 985 up to Chassis No. 6 502 399	1	
32	111 955 993 A	Twin jets - Washer unit	1	
33	311 971 913	Grommet - Washer unit from Chassis No. 112 2000 001	2	113, 114, 117, 118, 151, 152; M 1, M 108, M 110
	111.971 521 A	Hose 5x1.5x15	x	
34	211 259.295	Clip for pressure hose to washer valve from Chassis No. 112 2000 001	1	113, 114, 117, 118, 151, 152; M 1, M 108, M 110

Key No.	Part No.	Description	Quantity	Type and model
-	N 18 057 1	Hose 2.5X1.75	X	
35		250 mm - 9 <sup>27</sup> / <sub>32</sub> in. up to Chassis No. 117 999 000	1	
36		1500 mm - 59 <sup>1</sup> / <sub>16</sub> in. up to Chassis No. 117 999 000	1	
37		200 mm - 7 <sup>7</sup> / <sub>8</sub> in. from Chassis No. 118 000 001 up to 111 3200 000. from Chassis No. 112 2000 001	1 1	111, 113, 115, 117, 151 111, 115
(37)		250 mm - 9 <sup>27</sup> / <sub>32</sub> in. from Chassis No. 118 000 001 up to 111 3200 000 from Chassis No. 112 2000 001	1 1	112, 114, 116, 118, 152 112, 116
38		1850 mm - 72 <sup>27</sup> / <sub>32</sub> in. from Chassis No. 118 000 001 up to 110 3100 000 from Chassis No. 111 2000 001 up to 111 3200 000 from Chassis No. 112 2000 001	1 1 1	111, 113, 115, 117, 151 111, 115; M1: 113, 117 111, 115
(38)		2000 mm - 78 <sup>3</sup> / <sub>4</sub> in. from Chassis No. 118 000 001 up to 110 3100 000 from Chassis No. 111 2000 001 up to 111 3200 000 from Chassis No. 112 2000 001	1 1 1	112, 114, 116, 118, 152 112, 116; M1: 114, 118 112, 116
39		540 mm - 21 <sup>1</sup> / <sub>4</sub> in. from Chassis No. 112 2000 001	1	113, 114, 117, 118, 151, 152; M1
40		2360 mm - 92 <sup>29</sup> / <sub>32</sub> in. from Chassis No. 112 2000 001	1	113, 117, 151
(40)		1720 mm - 67 <sup>23</sup> / <sub>32</sub> in. from Chassis No. 112 2000 001	1	114, 118, 152
(40)		1920 mm - 75 <sup>19</sup> / <sub>32</sub> in. from Chassis No. 111 2000 001 up to 111 3200 000 from Chassis No. 112 2000 001	1 1	113, 114, 117, 118, 151, 152 M1

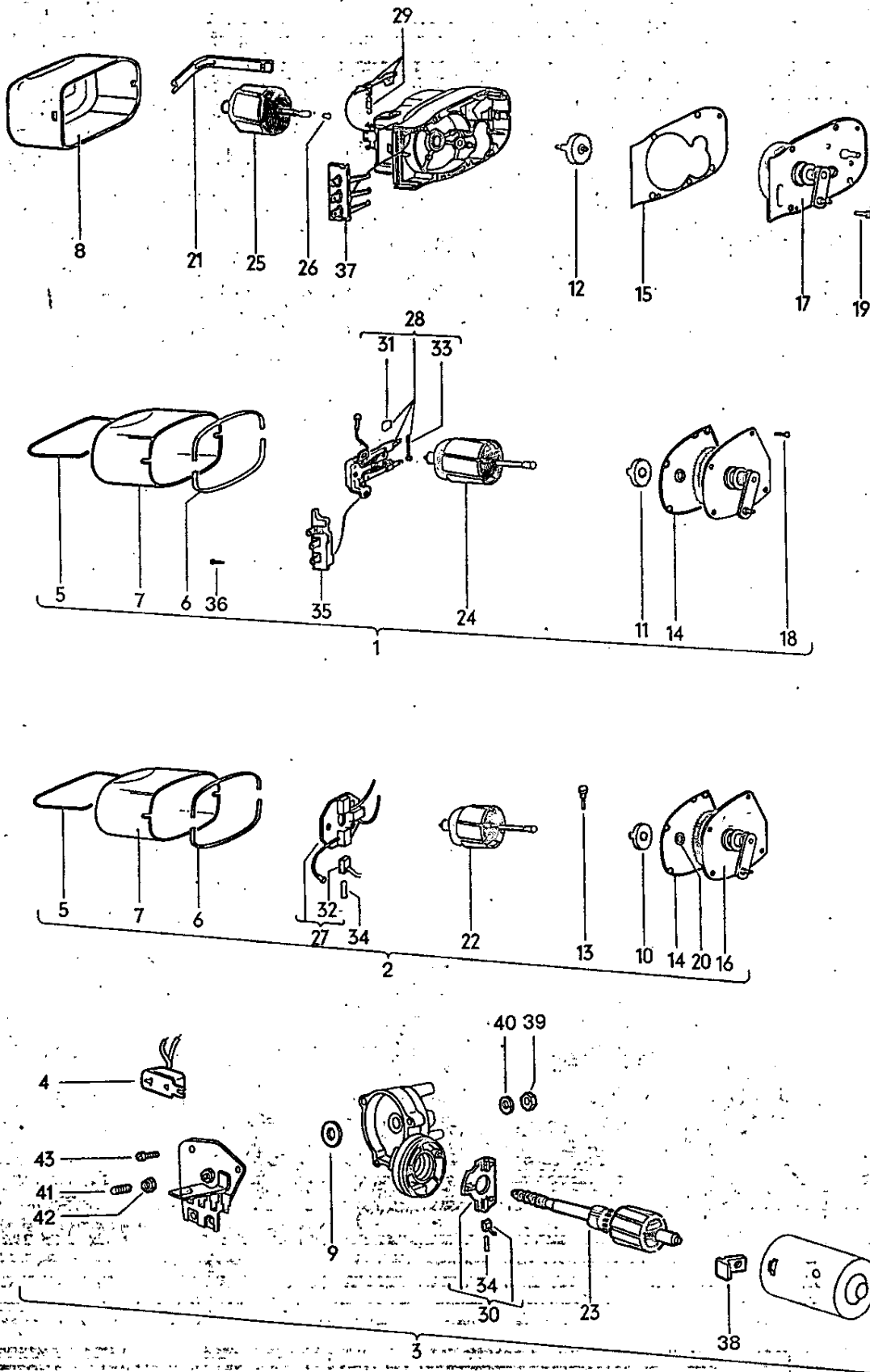

Wiper Motor-Versions

No.	Identification			from Chassis No	to Chassis No	Model	Part No.
1	111 955 111	SWF	6 V		1 600 439	111, 112, 115, 116	111 955 111 C
2	113 955 111	SWF	6 V		1 394 119	113, 117, 151	113 955 111 A
3	114 955 111	SWF	6 V		1 394 119	114, 118, 152	114 955 111 A
4	113 955 111 A	SWF	6 V	1 394 120	1 600 439	113, 117, 151	113 955 111 A
5	114 955 111 A	SWF	6 V	1 394 120	1 600 439	114, 118, 152	114 955 111 A
6	111 955 111 A	SWF	6 V	1 600 440	3 192 506	111, 112, 115, 116	111 955 111 C
7	113 955 111 B	SWF	6 V	1 600 440	3 192 506	113, 114, 117, 118, 151, 152	113 955 111 G
8	113 955 111 E	Bosch	6 V	1 600 440	3 192 506	113, 114, 117, 118, 151, 152	113 955 111 G
9	◆113 955 113	Bosch	12 V	1 600 440	6 502 399	M 613: 113, 117	113 955 113 A
10	◆113 955 113 A	SWF	12 V	1 600 440	6 502 399	M 613: 113, 117	113 955 113 A
11	111 955 111 C	SWF	6 V	3 192 507	6 502 399	111, 112, 115, 116	111 955 111 C
12	113 955 111 G	SWF	6 V	3 192 507	6 502 399	113, 114, 117, 118, 151, 152	113 955 111 G
13	113 955 111 H	Bosch	6 V	3 192 507	4 846 835	113, 114, 117, 118, 151, 152	113 955 111 G
14	113 955 111 P	Bosch	6 V	4 846 836	6 502 399	113, 114, 117, 118, 151, 152	113 955 111 G
15	113 955 111 Q	SWF	6 V	115 000 001	117 999 000	113, 114, 117, 118, 151, 152	113 955 111 Q
16	113 955 111 R	Bosch	6 V	115 000 001	117 999 000	113, 114, 117, 118, 151, 152	113 955 111 Q
17	◆113 955 111 S	SWF	6 V	115 000 001	117 999 000	M 50: 113, 114, 117, 118	113 955 111 Q
18	◆113 955 113 B	SWF	12 V	115 000 001	117 999 000	M 613	113 955 113 D
19	111 955 111 E	SWF	6 V	115 000 001	118 1016 100	111, 112, 115, 116	111 955 111 G
20	◆111 955 111 F	SWF	6 V	115 000 001	118 1016 100	M 50: 111, 112, 115, 116	111 955 111 G

Remark: ◆ screened  
+ use



No.	Identification			from Chassis No.	to Chassis No.	Model	Part No.
21	◇113 955 113 D	SWF	12 V	116 000 001 116 000 001	117 999 000	M 610/M 613 M 610	113 955 113 D
22	111 955 113	SWF	12 V	117 000 001		M 610/M 611	111 955 113
23	◇111 955 113 A	SWF	12 V	117 000 001		111-118, 151, 152	113 955 113 D
24	111 955 113 B	Bosch	12 V	117 000 001		M 610/M 611	111 955 113
25	111 955 113 D	SWF	12 V	118 000 001	118 1016 100	113, 114, 117, 118, 151, 152	111 955 113 F
26	◇111 955 113 E	SWF	12 V	118 000 001	118 1016 100	M 613: 113, 114, 117, 118, 151, 152	111 955 113 F + 311 035 691
27	◇111 955 113 G	SWF	12 V	119 000 001	119 1200 000	M 613: 113, 114, 117, 118, 151, 152	111 955 113 G + 311 035 691
28	111 955 113 F	SWF	12 V	119 000 001	119 1200 000	113, 114, 117, 118, 151, 152	111 955 113 F
29	111 955 111 G	SWF	6 V	119 000 001		111, 112, 115, 116	111 955 111 G
30	◇111 955 111 H	SWF	6 V	119 000 001		111, 112, 115, 116	111 955 111 G
31	113 955 113 E	Bosch/ SWF	12 V	110 2000 001	111 3200 000	113, 114, 117, 118, 151, 152	113 955 113 E
32	◇113 955 113 F	Bosch/ SWF	12 V	110 2000 001	111 3200 000	M 613: 113, 114, 117, 118, 151, 152	113 955 113 E + 311 955 203
33	113 955 113 G	Bosch/ SWF	12 V	112 2000 001		113, 114, 117, 118, 151, 152	113 955 113 G
34	◇113 955 113 H	SWF	12 V	112 2000 001		M 613: 113, 114, 117, 118, 151, 152	113 955 113 G + 311 955 203

Remark: ◇ screened  
+ use

Key No.	Part No.	Description	Quantity	Type and model
<b>WIPER MOTOR</b>				
(1)	111 955 111 C	Motor 6 V – Windshield wiper .....	1	
(1)	111 955 111 G	Motor 6 V – Windshield wiper .....	1	
(1)	113 955 111 A	Motor 6 V – Windshield wiper .....	1	
1	113 955 111 G	Motor 6 V – Windshield wiper .....	1	
(1)	113 955 111 Q	Motor 6 V – Windshield wiper .....	1	
(1)	114 955 111 A	Motor – Windshield wiper (RHD) 6 V .....	1	
(2)	111 955 113	Motor 12 V – Windshield wiper .....	1	
2	111 955 113 F	Motor 12 V – Windshield wiper .....	1	
(2)	111 955 113 G	Motor 12 V – Windshield wiper fully suppressed..	1	
(1)	113 955 113 A	Motor 12 V (screened) – Windshield wiper .....	1	
(1)	113 955 113 D	Motor 12 V (screened) – Windshield wiper .....	1	
(3)	113 955 113 E	Motor 12 V – Windshield wiper .....	1	
3	113 955 113 G	Motor 12 V – Windshield wiper .....	1	

Key No.	Part No.	Description	Quantity	Type and model
<b>WIPER MOTOR - PARTS</b>				
4	311 955 203	Suppressor choke - Wiper motors 32, 34	x	
5	113 955 731	Retaining spring - Cover - Windshield wiper motors 2-7, 10, 12, 15, 17-23, 25-30	1	
6	113 955 735	Gasket - Cover - Windshield wiper motors 10, 12, 15, 17-19, 21-23, 25-28	2	
7	113 955 741	Cover - Windshield wiper motors (SWF) 2-7, 10-12, 15, 17-23, 25-30	1	
(7)	113 955 741 A	Cover - Windshield wiper motors 8, 13	1	
8	113 955 741 B	Cover - Windshield wiper motors (Bosch) 14, 25	1	
(8)	113 955 741 D	Cover - Windshield wiper motor 16	1	
-	113 955 745	Sealing washer - Cover securing screw - Windshield wiper motors 8, 13	1	
9	311 955 749	Thrust washer - Gear - Windshield wiper motors 31-34	1	
10	113 955 751	Gear - Windshield wiper motors (SWF) 111 955 111 A/C, 113 955 111, 114 955 111, 111 955 113/A/D/E/F/G	1	
11	113 955 751 A	Gear - Windshield wiper motors 111 955 111 E/G/H, 113 955 111 A/B/G/O, 114 955 111 A, 113 955 113 A/B/D	1	
(11)	113 955 751 B	Gear - Windshield wiper motors 8, 13	1	
12	113 955 751 C	Gear - Windshield wiper motors (Bosch) 14, 16, 25	1	
(13)	113 955 759	Switch pin - Windshield wiper motors 8, 13	1	

**MAIN GROUP**



**ELECTRICAL EQUIPMENT**

Key No.	Part No.	Description	Quantity	Type and model
13	113 955 759 A	Switch pin - Windshield wiper motors 10, 15, 17, 18, 21-23, 25-28	1	
(13)	113 955 789	Switch pin - Windshield wiper motors 8, 13	1	
-	113 955 763	Cover plate - Windshield wiper motors 8, 13	1	
14	113 955 779	Gear cover gasket - Windshield wiper motors 2-7, 10-12, 15, 17-23, 25-30	1	
15	113 955 779 A	Gear cover gasket - Windshield wiper motors 14, 16	1	
(16)	111 955 781	Gear cover with gear and crank - Windshield wiper motor 1	1	
16	111 955 781 A	Gear cover with gear and crank - Windshield wiper motors 25-28	1	
(17)	113 955 781 A	Gear cover with gear and crank - Windshield wiper motor 4	1	
(17)	113 955 781 C	Gear cover with gear and crank - Windshield wiper motors 8, 13	1	
17	113 955 781 D	Gear cover with gear and crank - Windshield wiper motor 14	1	
(17)	113 955 781 E	Gear cover with gear and crank - Windshield wiper motors 15, 17-19, 21	1	
(17)	113 955 781 F	Gear cover with gear and crank - Windshield wiper motor 16	1	
18	N 10 803 2	Screw, fillister head AM 3.5X10	4	
19	N 10 697 1	Screw, cheese head AM 4X10	5	
-	113 955 783	Gear - Crank - Windshield wiper motors 8, 13	1	

Typ 1-5

Illustration **B62**

Key No.	Part No.	Description	Quantity	Type and model
20	113 955 785	Thrust washer – Gear – ..... Windshield wiper motors 1, 10-12, 15, 17-23, 25-30	1	
-	113 955 787	Crank – Windshield wiper motors 8, 13 .....	1	
21	113 955 805	Bracket – Armature – ..... Windshield wiper motor 14	1	
-	N 10 805 1	Screw, fillister head AM 3.5×5 .....	1	
-	N 12 131 2	Shake-proof washer J 3.7 .....	1	
22	111 955 811	Armature 12 V, inner dia. 12.5 mm (SWF) – ..... Windshield wiper motors 22, 23, 25-28	1	
(22)	111 955 811 A	Armature 12 V (Bosch) – Windshield wiper motors 25, 28	1	
(22)	113 955 811 B	Armature 12 V, inner dia. 12.5 mm – ..... Windshield wiper motors 10, 18, 21	1	
23	113 955 811 C	Armature 12 V (SWF) – Windshield wiper motors 31-34	1	
(23)	113 955 811 D	Armature 12 V (Bosch) – Windshield wiper motors 28, 31, 32	1	
(23)	113 955 811 E	Armature 12 V (Bosch) – ..... Windshield wiper motor 33	1	
(24)	111 955 813 A	Armature – Windshiled wiper motors 6, 11 .....	1	
(24)	111 955 813 C	Armature 6 V, inner dia. 12.5 mm – ..... Windshield wiper motors 15, 17, 19, 20, 29, 30	1	
(24)	113 955 813	Armature – Windshield wiper motors 2, 3 .....	1	
24	113 955 813 A	Armature – Windshield wiper motors 4, 5, 7, 12 .....	1	

Key No.	Part No.	Description	Quantity	Type and model
(24)	113 955 813 B	Armature - Windshield wiper motors 8, 13	1	
25	113 955 813 C	Armature - Windshield wiper motors 14, 16	1	
(25)	113 955 813 D	Armature - Windshield wiper motors inner dia. 9 mm 15, 19	1	
(25)	113 955 813 E	Armature - Windshield wiper motors inner dia. 9 mm 22, 23	1	
26	113 955 815 A	Thrust cone - Drive side - (Bosch) Windshield wiper motors 14, 16, 25	1	
-	113 955 835	Insulating plate - Windshield wiper motors 2, 3, 6, 11	1	
(27)	111 955 841	Yoke - Carbon brush - Windshield wiper motor 1	1	
27	111 955 841 A	Yoke - Carbon brush - Windshield wiper motors 22, 25, 28	1	
28	113 955 841 A	Yoke - Carbon brush - Windshield wiper motors 2-7, 10-12	1	
(28)	113 955 841 B	Yoke - Carbon brush - Windshield wiper motors 8, 13	1	
29	113 955 841 C	Yoke - Carbon brush - Windshield wiper motors 14, 16	1	
(29)	113 955 841 D	Yoke - Carbon brush - Windshield wiper motors 15, 17-21, 29, 30	1	
30	113 955 841 F	Yoke - Carbon brush - Windshield wiper motors 31-34	1	
(30)	113 955 841 G	Yoke - Carbon brush (Bosch) - Windshield wiper motors 31, 32	1	
(30)	113 955 841 H	Yoke - Carbon brush (Bosch) - Windshield wiper motor 33	1	



Key No.	Part No.	Description	Quantity	Type and model
(31)	111 955 849	Carbon brush – Windshield wiper motor 1 .....	2	
(32)	111 955 849 A	1 set of carbon brushes ..... Windshield wiper motor 25, 28	1	
(31)	113 955 849 A	Carbon brush – Windshield wiper motors 8, 13 ...	2	
31	113 955 849 B	Carbon brush – Windshield wiper motors ..... 2-7, 10, 15, 18-21, 29, 30	2	
32	113 955 849 C	Carbon brush – Windshield wiper motors ..... 22, 23, 25-28	3	
33	113 955 853 A	Spring for brush holder – Windshield wiper motors 2-7, 10-12, 15, 17-21, 29, 30	1	
(33)	113 955 853 B	Spring for brush holder – Windshield wiper motors 8, 13	1	
34	113 955 853 C	Spring for carbon brush SWF – Windshield wiper motors 22, 23, 25-28, 31-34	3	
35	113 955 857 B	Set of contact breakers – Windshield wiper motors 4, 7, 12, 15, 18	1	
36	N 11 361 1	Tapping screw, cheese head BZ 2.2×9.5 .....	2	
-	113 955 857 C	Set of contact breakers – Windshield wiper motors 8, 13	1	
37	113 955 857 D	Set of contact breakers – Windshield wiper motors 14, 16	1	
(37)	113 955 857 E	Set of contact breakers – Windshield wiper motors 9, 10, 22, 23, 25-28	1	
(37)	211 955 857 A	Set of contact breakers – Windshield wiper motors 19, 29	1	

**MAIN GROUP**



**ELECTRICAL EQUIPMENT**

Key No.	Part No.	Description	Quantity	Type and model
38	311 955 865	Bracket - Gear cover - Windshield wiper motor 31, 32	2	
39	N 11 006 2	Nut, hex. M 6	1	
40	N 12 105 1	Spring washer A 6.4	1	
41	N 13 010 1	Stud M 5×12	1	
42	N 11 005 2	Nut, hex. M 5	1	
43	N 10 703 2	Screw, cheese hd. AM 4×8	4	

Typ 1-3

Illustration **B 62**

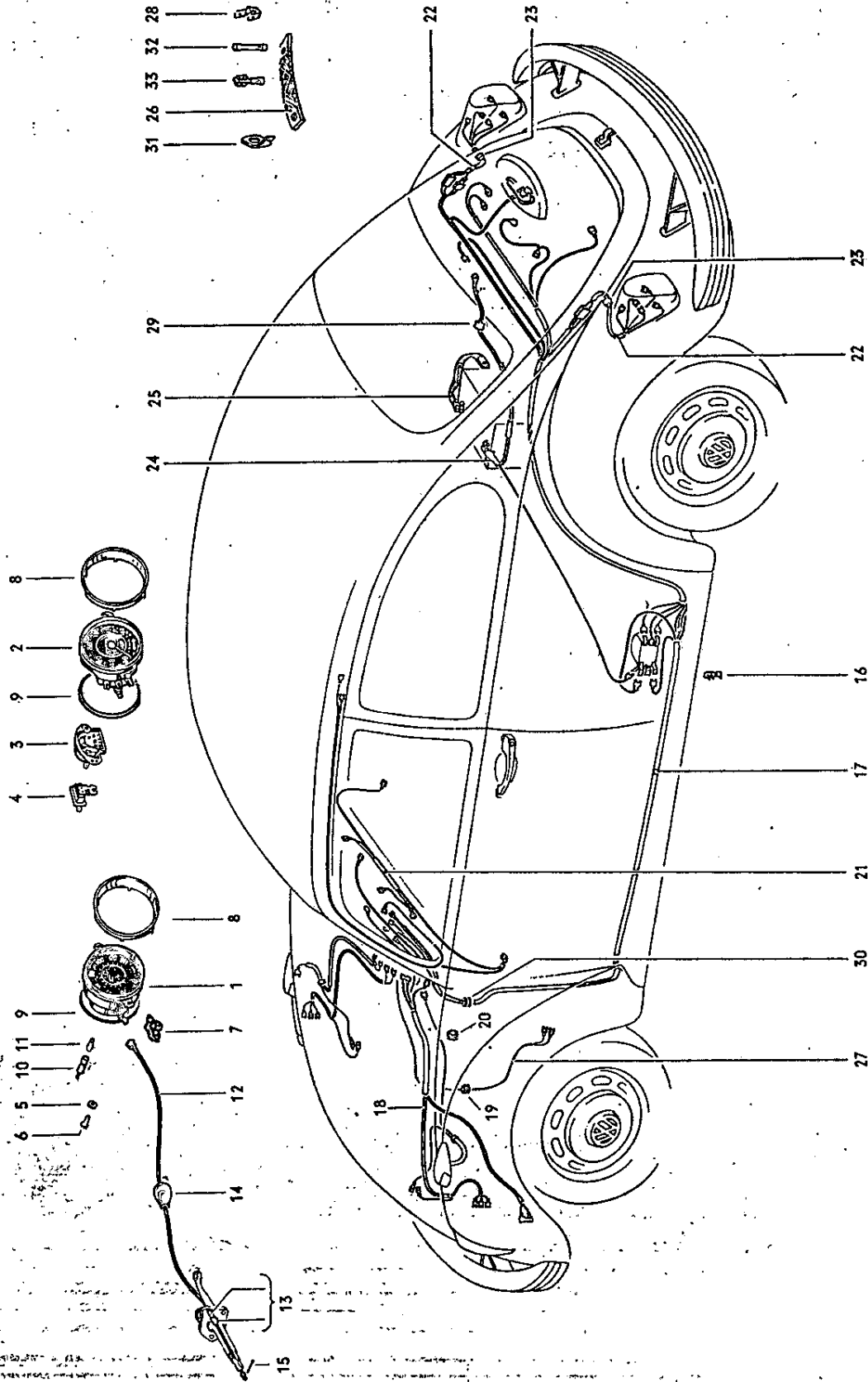

Key No.	Part No.	Description	Quantity	Type and model
<b>SPEEDOMETER</b>				
1	111 957 021 M	Speedometer ..... from Chassis No. 1 - 397 023 up to 117 999 000 from Chassis No. 118 000 001 up to 111 3200 000	1 1	111, 112, 115, 116
-	111 957 021 P	Speedometer ..... from Chassis No. 112 2000 001	1	111, 112, 115, 116; M 34: 111, 112, 115, 116
-	113 957 021	Speedometer ..... up to Chassis No. 1 - 397 022	1	
-	111 957 023 J	* Speedometer (miles) ..... from Chassis No. 1 - 397 023 up to 117 999 000 from Chassis No. 118 000 001 up to 111 3200 000 from Chassis No. 110 2000 001 up to 111 3200 000	1 1 1	M 20 M 20: 111, 112, 115, 116 M 9/M 20
-	111 957 023 L	Speedometer (miles) ..... from Chassis No. 112 2000 001	1	M 20: 111, 112, 115, 116; M 9/M 20
-	113 957 023	* Speedometer (miles) ..... up to Chassis No. 1 - 397 022	1	M 20
-	111 957 031 B	Speedometer with trip recorder ..... from Chassis No. 1 - 397 023 up to 117 999 000 from Chassis No. 118 000 001	1 1	111, 112, 115, 116
-	111 957 033 B	Speedometer with trip recorder (miles) ..... from Chassis No. 1 - 397 023 up to 117 999 000 from Chassis No. 118 000 001	1 1	111, 112, 115, 116
-	113 957 055 B	Speedometer without fuel gauge ..... from Chassis No. 118 000 001 up to 111 3200 000 from Chassis No. 110 2000 001 up to 111 3200 000	1 1	113, 114, 117, 118, 151, 152 M 40
2	113 957 055 C	Speedometer without fuel gauge ..... from Chassis No. 112 2000 001	1	113, 114, 117, 118, 151, 152; M 40
-	113 957 057	* Speedometer (miles) without fuel gauge ..... from Chassis No. 118 000 001 up to 118 1016 100	1	M 20: 113, 114, 117, 118 151, 152
-	113 957 057 A	Speedometer (miles) without fuel gauge ..... from Chassis No. 118 000 001 up to 118 1016 100	x	113, 114, 117, 118, 151, 152
-	113 957 057 D	* Speedometer (miles) reading in tenths without fuel gauge ..... from Chassis No. 118 1003 668 up to 111 3200 000	1	M 20: 113, 114, 117, 118 151, 152

Key No.	Part No.	Description	Quantity	Type and model
-	113 957 057 E	Speedometer (miles) reading in tenths without fuel gauge from Chassis No. 112 2000 001	1	M 20; 113, 114, 117, 118, 151, 152
-	113 957 063 A <i>SSB</i> <i>113 957 063 B</i>	Fuel gauge (electrical) ..... from Chassis No. 118 000 001 up to 111 3200 000 from Chassis No. 110 2000 001 up to 111 3200 000	1 1	113,114,117,118,151,152 M 40
3	113 957 063 B	Fuel gauge (electric) ..... from Chassis No. 112 2000 001	1	113, 114, 117, 118, 151, 152; M 40
4	113 957 099	Vibrator - Fuel gauge ..... from Chassis No. 118 000 001 from Chassis No. 110 2000 001	1 1	113, 114, 117, 118, 151, 152 M 40
5	N 11 523 3	Washer A 5.3 .....	2	
6	N 10 700 1	Screw, cheese head AM 5x12 .....	2	
7	111 957 351	Support for warning lights on speedometer ..... from Chassis No. 1 - 397 023	1	
-	111 957 361 A	Glass with retaining ring for speedometer ..... from Chassis No. 1 - 397 023	1	
-	113 957 371	Ornamental ring - Speedometer ..... from Chassis No. 1 - 397 023 up to 1 600 439	1	113, 114, 117, 118, 151, 152
-	113 957 371 C	Ornamental ring - Speedometer ..... from Chassis No. 1 600 440 up to 110 3100 000 from Chassis No. 111 2000 001 up to 111 3200 000	1 1	113, 114, 117, 118, 151, 152 113, 114, 117, 118
-	113 957 371 D *	Ornamental ring - Speedometer ..... from Chassis No. 118 000 001 up to 118 1016 100 from Chassis No. 119 000 001 up to 110 3100 000 from Chassis No. 111 2000 001 up to 111 3200 000	1 1 1	M 23, M 601, M 602 M 228 151, 152; M 228
8	113 957 371 E	Ornamental ring - Speedometer ..... from Chassis No. 112 2000 001	1	113, 114, 117, 118
-	113 957 371 F	Ornamental ring - Speedometer ..... from Chassis No. 111 2000 001	1	151, 152; M 228
-	111 957 375	Gasket - Speedometer ..... up to Chassis No. 1 - 397 022	1	
9	111 957 375 A	Gasket - Speedometer ..... from Chassis No. 1 - 397 023	1	
-	111 957 379	Cap - Warning light opening ..... from Chassis No. 118 000 001	x	

Key No.	Part No.	Description	Quantity	Type and model
<b>SPEEDOMETER</b>				
1	111 957 021 M	Speedometer from Chassis No. 1 - 397 023 up to 117 999 000 from Chassis No. 118 000 001 up to 111 3200 000	1 1	111, 112, 115, 116
-	111 957 021 P	Speedometer from Chassis No. 112 2000 001	1	111, 112, 115, 116; M 34: 111, 112, 115, 116
-	113 957 021	Speedometer up to Chassis No. 1 - 397 022	1	
-	111 957 023 J	* Speedometer (miles) from Chassis No. 1 - 397 023 up to 117 999 000 from Chassis No. 118 000 001 up to 111 3200 000 from Chassis No. 110 2000 001 up to 111 3200 000	1 1 1	M 20 M 20: 111, 112, 115, 116 M 9/M 20
-	111 957 023 L	Speedometer (miles) from Chassis No. 112 2000 001	1	M 20: 111, 112, 115, 116; M 9/M 20
-	113 957 023	* Speedometer (miles) up to Chassis No. 1 - 397 022	1	M 20
-	111 957 031 B	Speedometer with trip recorder from Chassis No. 1 - 397 023 up to 117 999 000 from Chassis No. 118 000 001	1 1	111, 112, 115, 116
-	111 957 033 B	Speedometer with trip recorder (miles) from Chassis No. 1 - 397 023 up to 117 999 000 from Chassis No. 118 000 001	1 1	111, 112, 115, 116
-	113 957 055 B	Speedometer without fuel gauge from Chassis No. 118 000 001 up to 111 3200 000 from Chassis No. 110 2000 001 up to 111 3200 000	1 1	113, 114, 117, 118, 151, 152 M 40
2	113 957 055 C	Speedometer without fuel gauge from Chassis No. 112 2000 001	1	113, 114, 117, 118, 151, 152; M 40
-	113 957 057	* Speedometer (miles) without fuel gauge from Chassis No. 118 000 001 up to 118 1016 100	1	M 20: 113, 114, 117, 118 151, 152
-	113 957 057 A	Speedometer (miles) without fuel gauge from Chassis No. 118 000 001 up to 118 1016 100	x	113, 114, 117, 118, 151, 152
-	113 957 057 D	* Speedometer (miles) reading in tenths without fuel gauge from Chassis No. 118 1003 668 up to 111 3200 000	1	M 20: 113, 114, 117, 118 151, 152



Key No.	Part No.	Description	Quantity	Type and model
-	113 957 057 E	Speedometer (miles) reading in tenths without fuel gauge from Chassis No. 112 2000 001	1	M 20; 113, 114, 117, 118, 151, 152
-	113 957 063 A	Fuel gauge (electrical) from Chassis No. 118 000 001 up to 111 3200 000	1	113,114,117,118,151,152
	113 957 063 B	Fuel gauge (electric) from Chassis No. 110 2000 001 up to 111 3200 000	1	M 40
3	113 957 063 B	Fuel gauge (electric) from Chassis No. 112 2000 001	1	113, 114, 117, 118, 151, 152; M 40
4	113 957 099	Vibrator - Fuel gauge from Chassis No. 118 000 001	1	113, 114, 117, 118, 151, 152
		from Chassis No. 110 2000 001	1	M 40
5	N 11 523 3	Washer A 5.3	2	
6	N 10 700 1	Screw, cheese head AM 5x12	2	
7	111 957 351	Support for warning lights on speedometer from Chassis No. 1 - 397 023	1	
-	111 957 361 A	Glass with retaining ring for speedometer from Chassis No. 1 - 397 023	1	
-	113 957 371	Ornamental ring - Speedometer from Chassis No. 1 - 397 023 up to 1 600 439	1	113, 114, 117, 118, 151, 152
-	113 957 371 C	Ornamental ring - Speedometer from Chassis No. 1 600 440 up to 110 3100 000	1	113, 114, 117, 118, 151, 152
		from Chassis No. 111 2000 001 up to 111 3200 000	1	113, 114, 117, 118
-	113 957 371 D *	Ornamental ring - Speedometer from Chassis No. 118 000 001 up to 118 1016 100	1	M 23, M 601, M 602
		from Chassis No. 119 000 001 up to 110 3100 000	1	M 228
		from Chassis No. 111 2000 001 up to 111 3200 000	1	151, 152; M 228
8	113 957 371 E	Ornamental ring - Speedometer from Chassis No. 112 2000 001	1	113, 114, 117, 118
-	113 957 371 F	Ornamental ring - Speedometer from Chassis No. 111 2000 001	1	151, 152; M 228
-	111 957 375	Gasket - Speedometer up to Chassis No. 1 - 397 022	1	
9	111 957 375 A	Gasket - Speedometer from Chassis No. 1 - 397 023	1	
-	111 957 379	Cap - Warning light opening from Chassis No. 118 000 001	X	

3564  
113957063B

Key No.	Part No.	Description	Quantity	Type and model
10	111 957 397	Socket - Bulb .....	5	
		up to Chassis No. 117 999 000	5	111, 112, 115, 116
		from Chassis No. 118 000 001	6	113,114,117,118,151,152
-	113 957 397	Socket - Oil pressure warning lamp .....	1	M 9
-	N 17 722 1	Bulb J 6 V, 1.2 W .....	5	111, 112, 115, 116
11	N 17 722 2	up to Chassis No. 117 999 000	5	M 613
		from Chassis No. 118 000 001	6	113,114,117,118,151,152; M1
-	111 957 801 G	Cable, length: 1355 mm - 53 11/32 in. - .....	1	111, 113, 115, 117, 151
		Speedometer		
		up to Chassis No. 1 - 397 022.		
-	111 957 801 H	Cable, length: 1275 mm - 50 3/16 in. - .....	1	111, 113, 115, 117, 151
		Speedometer		
		from Chassis No. 1 - 397 023 up to 1 600 439		
-	111 957 801 J	Cable, length: 1235 mm - 48 5/8 in. - .....	1	111, 113, 115, 117, 151
		Speedometer		
		from Chassis No. 1 600 440 up to 115 999 000		
12	111 957 801 K	Cable, length: 1195 mm - 47 1/16 in. - .....	1	113, 117, 151
		Speedometer		
		from Chassis No. 116 000 001 up to 110 3100 000	1	111, 115
		from Chassis No. 111 2000 001	1	M 1: 113, 117
-	112 957 801 H	Cable, length: 1625 mm - 63 31/32 in. - .....	1	112, 114, 116, 118, 152
		Speedometer (RHD)		
		from Chassis No. 1 - 397 023 up to 1 600 439		
-	112 957 801 K	Cable, length: 1585 mm - 62 13/32 in. - .....	1	112, 114, 116, 118, 152
		Speedometer (RHD)		
		up to Chassis No. 1 - 397 022 and		
		from Chassis No. 1 600 440 up to 115 999 000		
-	112 957 801 J	Cable, length: 1545 mm - 60 13/16 in. - .....	1	114, 118, 152
		Speedometer (RHD)		
		from Chassis No. 116 000 001 up to 110 3100 000	1	112, 116
		from Chassis No. 116 000 001	1	M 1: 114, 118
		from Chassis No. 111 2000 001	1	
-	113 957 801 A	Cable, length: 1390 mm - 54 23/32 in. - .....	1	113, 117, 151
		Speedometer		
		from Chassis No. 111 2000 001		
-	142 957 801 C	Cable, length: 1860 mm - 73 7/32 in. - .....	1	114, 118, 152
		Speedometer		
		from Chassis No. 111 2000 001		
13	111 957 855 B	Grommet - Speedometer cable	1	

Key No.	Part No.	Description	Quantity	Type and model
-	113 957 855	Grommet for speedometer cable in Bracket ..... from Chassis No. 111 2000 001	1	113, 114, 117, 118, 151, 152
-	113 957 855 A	Grommet for drive shaft in side member ..... from Chassis No. 111 2000 001	1	113, 114, 117, 118, 151, 152
14	111 957 861	Grommet - Speedometer cable in side panel .... from Chassis No. 3 192 507 up to 110 3100 000 from Chassis No. 111 2000 001	1 1 1	111, 112, 115, 116
15	N 12 512 1	Cotter pin 2X12 ..... up to Chassis No. 117 999 000	1	
-	N 12 434 1	Lock washer 4 ..... from Chassis No. 118 000 001	1	

ELECTRIC WIRING

-	111 971 011	Main harness ..... up to Chassis No. 1 - 397 022	1	111, 113, 115, 117
-	111 971 011 A	Main harness ..... from Chassis No. 1 - 397 023 up to 1 - 575 414	1	111, 113, 115, 117
-	111 971 011 AH	Main harness in side member ..... (with connection for test socket) from Chassis No. 111 2000 001	1	111, 115
-	112 971 011 D	Main harness ..... from Chassis No. 1 600 440 up to 3 192 506	1	112, 114, 116, 118
-	112 971 011 AH	Main harness in side member ..... (with connection for test socket) from Chassis No. 111 2000 001	1	112, 116
-	113 971 011	Main harness ..... Germany only: from Chassis No. 3 192 507 up to 3 856 471 Export only: from Chassis No. 3 192 507 up to 4 010 994	1	111, 113, 115, 117
-	113 971 011 N	Main harness in side member ..... (without connection for test socket) from Chassis No. 112 2000 001	1	113, 117, 151; M 1: 113, 117; M 52/M 610: 111, 115
-	113 971 011 DJ	Main harness in side member ..... (with connection for test socket) from Chassis No. 111 2000 001	1	113, 117, 151; M 1: 113, 117; M 52/M 610: 111, 115; M 102
-	114 971 011	Main harness ..... from Chassis No. 3 192 507 up to 4 010 994	1	112, 114, 116, 118

Key No.	Part No.	Description	Quantity	Type and model
-	113 971 011 DJ	Main harness in side member ..... (with connection for test socket) from Chassis No. 111 2000 001 up to 111 3200 000	1	113, 117, 151; M 1: 113, 117; M 52/M 610: 111, 115; M 102
-	113 971 011 EL	Main harness in side member ..... (with connection for test socket) from Chassis No. 112 2000 001	1	113, 117, 151; M 1: 113, 117; M 52/M 610: 111, 115; M 102
-	114 971 011	Main harness ..... from Chassis No. 3 192 507 up to 4 010 994	1	112, 114, 116, 118
-	114 971 011 N	Main harness in side member ..... (without connection for test socket) from Chassis No. 111 2000 001 up to 111 3200 000	1	114, 118, 152; M 1: 114, 118; M 52/M 610: 112, 116
-	114 971 011 DJ	Main harness in side member ..... (with connection for test socket) from Chassis No. 111 2000 001 up to 111 3200 000	1	114, 118, 152; M 1: 114, 118; M 52/M 610: 112, 116; M 102
-	114 971 011 EL	Main harness in side member ..... (with connection for test socket) from Chassis No. 112 2000 001	1	114, 118, 152; M 1: 114, 113 M 52/M 610: 112, 116; M 102
-	151 971 011 G	Main harness ..... from Chassis No. 1 600 440 up to 3 192 506	1	151
-	151 971 011 H	Main harness ..... Germany only: from Chassis No. 3 192 507 up to 3 856 471 Export only: from Chassis No. 3 192 507 up to 4 010 994	1	151
-	111 971 013 B	Main harness in roof member ..... from Chassis No. 1 600 440 up to 3 192 506	1	111, 113, 115, 117
-	151 971 013 D *	Main harness (flashing indicator) ..... from Chassis No. 2 528 668 up to 3 192 506	1	M 22: 151
-	113 971 015 B	Main harness (RHD) in roof member ..... Germany only: from Chassis No. 3 856 472 up to 6 502 399 Export only: from Chassis No. 4 010 995 up to 6 502 399	1	111, 113, 115, 117
-	113 971 015 H	Main harness in side member ..... from Chassis No. 115 000 001 up to 116 1021 300	1	111, 113, 115, 117, 151
-	114 971 015 B	Main harness ..... from Chassis No. 4 010 995 up to 6 502 399	1	112, 114, 116, 118
-	114 971 015 H	Main harness ..... from Chassis No. 115 000 001 up to 116 1021 300	1	112, 114, 116, 118, 152



Key No.	Part No.	Description	Quantity	Type and model
-	152 971 015 C	Main harness ..... from Chassis No. 4 010 995 up to 6 502 399	1	152
-	211 971 119 A	Ground cable - Relay ..... from Chassis No. 115 000 001 up to 116 1021 300	1	
16	111 863 157	Clip for main harness ..... from Chassis No. 115 000 001	2	
-	111 971 022 C	Main harness in side member ..... (without connection for test socket) from Chassis No. 117 000 001 up to 117 999 000	1	M 86, M 129: 111, 115; M 88: 113, 117, 151
		from Chassis No. 118 000 001 up to 111 3200 000	1	111, 115
-	112 971 022 C	Main harness in side member ..... (without connection for test socket) from Chassis No. 117 000 001 up to 117 999 000	1	M 86, M 129: 112, 116; M 88: 114, 118, 152
		from Chassis No. 118 000 001 up to 111 3200 000	1	112, 116
17	113 971 023 F	Main harness in side member ..... from Chassis No. 117 000 001 up to 117 999 000	1	111, 113, 115, 117, 151
		from Chassis No. 118 000 001 up to 110 3100 000	1	113, 117, 151; M 52: 111, 115
-	114 971 023 F	Main harness in side member ..... from Chassis No. 117 000 001 up to 117 999 000	1	112, 114, 116, 118, 152
		from Chassis No. 118 000 001 up to 110 3100 000	1	114, 118, 152; M 52: 112, 116
-	111 971 031	Harness - Headlamp ..... up to Chassis No. 1 - 575 414	1	
-	111 971 041 A	Harness - Foot dipper switch and fuse box ..... from Chassis No. 1 - 397 023 up to 1 - 575 414	1	111, 115
-	112 971 069 B	* Harness front, left ..... from Chassis No. 118 000 001 up to 110 3100 000	1	M 23: 114, 118, 152
-	113 971 069 B	* Harness front, left ..... from Chassis No. 118 000 001 up to 110 3100 000	1	M 23: 113, 117, 151
-	111 971 070	* Harness front, right ..... from Chassis No. 118 000 001 up to 110 3100 000	1	M 23: 111, 113, 115, 117, 151
-	114 971 070	* Harness front, right ..... from Chassis No. 118 000 001 up to 110 3100 000	1	M 23: 114, 118, 152
		from Chassis No. 111 2000 001 up to 111 2799 842	1	M 1/M 23: 114, 118

Key No.	Part No.	Description	Quantity	Type and model
-	113 971 071 AA	Harness front ..... from Chassis No. 111 2000 001 up to 111 2799 842	1	113, 117, 151
-	113 971 071 AC	Harness front ..... from Chassis No. 111 2799 843	1	113, 117, 151
-	113 971 071 AD	Harness front ..... from Chassis No. 111 2000 001	1	M 23: 113, 117, 151
-	114 971 071 AA	Harness front ..... from Chassis No. 111 2000 001 up to 111 2799 842	1	114, 118, 152
-	114 971 071 AC	Harness front ..... from Chassis No. 111 2799 843	1	114, 118, 152
-	114 971 071 AD	Harness front ..... from Chassis No. 111 2000 001	1	M 22: 114, 118, 152
-	111 971 075 E	Harness front ..... from Chassis No. 2 528 668 up to 3 192 506	1	111, 115
-	111 971 075 F	Harness front, left ..... from Chassis No. 3 192 507 up to 4 010 994	1	111, 115
-	111 971 075 G	Harness front, left ..... from Chassis No. 4 010 995 up to 4 630 937	1	111, 115
-	113 971 075	Harness front ..... from Chassis No. 1 - 575 415 up to 1 - 929 745	1	113, 117, 151
-	113 971 075 C	Harness front ..... from Chassis No. 1 600 440 up to 2 528 667	1	113, 117, 151
-	114 971 075 C	Harness front ..... from Chassis No. 1 600 440 up to 2 528 667	1	114, 118
-	113 971 077 C *	Harness front ..... from Chassis No. 1 - 575 415 up to 1 - 929 745	1	M22: 111, 113, 115, 117, 151
-	113 971 077 F	Harness front ..... from Chassis No. 2 528 668 up to 3 192 506	1	113, 117, 151
-	111 971 079 F	Harness front, left ..... from Chassis No. 118 000 001 up to 118 1016 100	1	111, 113, 115, 117, 151
-	112 971 079 B	Harness front left (RHD) and front right (LHD) ..... from Chassis No. 118 000 001 up to 118 1016 100	1	
18	112 971 079 C	Harness front, left and front right ..... from Chassis No. 119 000 001 up to 110 3100 000 from Chassis No. 111 2000 001 up to 111 2799 842	2 2	111, 112, 115, 116; M 1



Key No.	Part No.	Description	Quantity	Type and model
-	112 971 080 D	Harness front, right from Chassis No. 118 000 001 up to 118 1016 100	1	112, 114, 116, 118, 152
-	111 971 089 C	Harness front, left from Chassis No. 116 000 001 up to 116 1021 300	1	111, 115
-	111 971 089 D *	Harness front, left: from Chassis No. 116 000 001 up to 116 1021 300 from Chassis No. 117 000 001 up to 117 999 000 front left (LHD) and front right: from Chassis No. 118 000 001 up to 110 3100 000 from Chassis No. 111 2000 001 up to 111 2799 842	1 1 2 2	113, 117, 151 111, 113, 115, 117, 151 M 22, M 110 M 22: 111, 112, 115, 116; M 1/M 22
-	112 971 089 A	Harness front, left from Chassis No. 3 192 507 up to 6 502 399 from Chassis No. 115 000 001 up to 115 999 000	1 1	112, 114, 116, 118, 152 112, 116
-	112 971 089 C	Harness front left (RHD) and front right (LHD) from Chassis No. 116 000 001 up to 117 999 000	1	
-	113 971 089 B	Harness front, left from Chassis No. 3 192 507 up to 115 999 000	1	111, 113, 115, 117, 151
-	111 971 090	Harness front, right from Chassis No. 3 192 507 up to 115 999 000	1	111, 113, 115, 117, 151
-	112 971 090 C	Harness front, right from Chassis No. 116 000 001 up to 116 1021 300	1	112, 116
-	112 971 090 D	Harness front, right from Chassis No. 116 000 001 up to 117 999 000 from Chassis No. 117 000 001 up to 117 999 000	1 1	114, 118, 152 112, 116
-	114 971 090 A	Harness front, right from Chassis No. 3 192 507 up to 115 999 000	1	112, 114, 116, 118, 152
-	111 971 091	Harness front, left from Chassis No. 117 000 001 up to 117 999 000	1	M 611:111, 113, 115, 117, 151
-	112 971 091 *	Harness front, left (RHD) front, right (LHD) from Chassis No. 117 000 001 up to 117 999 000 from Chassis No. 118 000 001 up to 110 3100 000 from Chassis No. 111 2000 001 up to 111 2799 842	1 1 1	M 611, M 110 M 110 M 1, M 110
-	114 971 101	Harness - Interior light from Chassis No. 111 2000 001	1	113, 114, 117, 118; M 1

Key No.	Part No.	Description	Quantity	Type and model
-	311 906 105	Grommet 33×8.5 – Main harness ..... from Chassis No. 151 2000 001	1	151, 152
19	111 953 547	Grommet – Front harness through front partition ..... from Chassis No. 3 192 507 up to 117 999 000	1	
20	141 971 907	Seal – Front harness through ..... luggage compartment from Chassis No. 3 192 507 up to 115 999 000 from Chassis No. 116 000 001 up to 118 1016 100	1 1	111, 112, 115, 116
-	113 971 105 C	Harness – Interior light ..... from Chassis No. 3 192 507 up to 116 1021 300	1	113, 117
-	114 971 105 B	Harness – Interior light ..... from Chassis No. 3 192 507 up to 6 502 399	1	114, 118
21	114 971 105 C	Harness – Interior light ..... from Chassis No. 115 000 001 up to 116 1021 300 from Chassis No. 117 000 001 up to 110 3100 000	1 1	114, 118 113, 114, 117, 118
-	114 971 115	Cable – Direction indicator ..... from Chassis No. 1 600 440 up to 2 528 667	1	112, 114, 116, 118
-	111 971 167 B	Cable – Tail light (length 1300 mm) ..... Germany only: from Chassis No. 3 192 507 up to 3 856 471 Export only: from Chassis No. 3 192 507 up to 4 010 994	1	
-	111 971 168	Cable – Tail light (length 750 mm) ..... up to Chassis No. 3 192 506	1	
-	111 971 168 B	Cable – Tail light (length 500 mm) ..... Germany only: from Chassis No. 3 192 507 up to 3 856 471 Export only: from Chassis No. 3 192 507 up to 4 010 994	1	
22	111 971 169 H	Cable – Stop/flashing indicator light with ..... back-up lamp Germany only: from Chassis No. 3 856 472 up to 118 1016 100 Export only: from Chassis No. 4 010 995 up to 118 1016 100 from Chassis No. 119 000 001 up to 110 3100 000 from Chassis No. 111 2000 001	2 2 2 2	111, 112, 115, 116; M 1
23	111 971 911	Grommet 16.5×4: .....	2	



Key No.	Part No.	Description	Quantity	Type and model
-	111 971 185	Cable - Horn ..... up to Chassis No. 1 - 397 022	1	
-	111 971 185 A	Cable - Horn ..... from Chassis No. 1 - 397 023 up to 1 - 575 414	1	
-	111 971 189	Cable - Horn buffon ..... up to Chassis No. 2 528 667 from Chassis No. 2 528 668 up to 116 1021 300	1 1	111, 112, 115, 116
-	113 971 189 A	Ground cable between horn half ring ..... and steering coupling from Chassis No. 4 010 995 up to 116 1021 300 from Chassis No. 117 000 001 up to 110 3100 000 from Chassis No. 111 2000 001	1 1 1	113, 114, 117, 118, 151, 152 111, 112, 115, 116; M 1
-	111 971 215 A	Ground strip - Windshield wiper motor ..... from Chassis No. 1 600 440	1	
-	N 13 961 2	Tapping screw, fillister head B 3.9x13 .....	1	
-	111 971 225	Cable - Starter ..... up to Chassis No. 116 1021 300	1	
24	311 971 225 C 330y 311 971 228	Cable - Starter ..... from Chassis No. 117 000 001	1	
-	111 971 227	Cable - Starter (for second battery) .....	1	
25	147 971 235 330y 111 971 235	Strap - Battery ground ..... up to Chassis No. 1 - 929 745 from Chassis No. 118 000 001	1 1	
-	N 10 237 5	Bolt, hex. head M 8x12 .....	1	
-	111 821 149 A	Lock washer .....	1	
-	111 971 235 C	Strap - Battery ground ..... from Chassis No. 1 - 929 746 up to 117 999 000	1	
-	111 971 237 A	Ground strap - Transmission to Chassis .....	1	
-	111 971 245	Ground strip for licence plate light (conversion) ..... from Chassis No. 1 - 397 023 up to 1 600 439 (see Technical Bulletin E 7)	1	

Key No.	Part No.	Description	Quantity	Type and model
26	111 971 246	Ground strap – Steering coupling up to Chassis No. 6 502 399 from Chassis No. 115 000 001	1 1	111, 112, 115, 116
27	112 971 320	Cable harness – Brake light switch from Chassis No. 118 000 001	1	113, 114, 117, 118, 151, 152; M 139
-	114 971 320 C * USA.	Cable harness – Brake light switch from Chassis No. 118 000 001 up to 110 3100 000	1	M 50
-	111 971 349	Cable harness between regulator and generator.. from Chassis No. 116 000 001 up to 116 1021 300	1	M 610
-	111 971 503	Test socket – Main harness from Chassis No. 111 2000 001	1	
-	N 13 965 1	Tapping screw, fillister hd. B 4.2×9.5 from Chassis No. 111 2000 001	2	
28	111 971 511	Cable divider – Fuse box	x	
-	111 971 519 A	Flat terminal – Ground connection from Chassis No. 119 000 001 up to 111 3200 000	x	
-	111 971 519 C	Flat terminal – Ground connection from Chassis No. 112 000 001	x	
-	113 971 771 A	Cable harness – Transmission from Chassis No. 118 071 440 up to 111 2250 395	1	M 9
-	113 971 771 B	Cable harness – Transmission from Chassis No. 111 2250 396 (see Workshop Bulletin H 20)	1	M 9
-	113 971 901	Cap (rubber) – Generator for terminal D+ from Chassis No. 111 2000 001	1	113, 114, 117, 118, 151, 152; M 1
-	113 971 901 A	Cap (rubber) – Generator for terminal DF from Chassis No. 111 2000 001	1	113, 114, 117, 118, 151, 152; M 1
29	111 971 905	Grommet – Starter cable	1	
30	111 971 907	Seal – Main harness from Chassis No. 115 000 001 up to 117 999 000 from Chassis No. 118 000 001	1 1	113, 114, 117, 118, 151, 152
-	141 971 907	Grommet for luggage compartment up to Chassis No. 117 999 000	1	111, 112, 115, 116



Key No.	Part No.	Description	Quantity	Type and model
-	311 971 907	☆ Grommet - Hose ..... from Chassis No. 110 2000 001	2	M 26
-	111 971 909	Grommet - Main harness ..... from Chassis No. 115 000 001	1	
-	111 971 911	Grommet - Cross member, rear and partition front. from Chassis No. 115 000 001	3	
-	311 971 913	Grommet - cable .....	2 1	111, 112, 115, 116
-	311 971 921	Cap (rubber) - Flat terminal .....	x	
-	113 971 923	Cap - Grommet ..... from Chassis No. 115 000 001	2	M 102
-	111 971 931	Angle terminal sleeve F 6.3x1 - Cable B 0.5-2.5 from Chassis No. 118 071 440	x	M 9
31	113 971 935	Push-on connector - Steering coupling ..... up to Chassis No. 115 999 000 from Chassis No. 116 000 001 up to 110 3100 000 from Chassis No. 111 2000 001 up to 111 3200 000	1 1 1	113, 114, 117, 118, 151, 152 111, 112, 115, 116; M 1
-	311 971 935	Push-on connector - Steering coupling ..... from Chassis No. 112 2000 001	1	111, 112, 115, 116; M 1
-	113 971 935 A	Push-on connector - Speedometer ..... and indicator switch	1	
-	111 971 938	Buff connector yellow - Cable 4.0 - 6.0 .....	x	
32	111 971 939	Buff connector blue - Cable 1.5 - 2.5 .....	x	
-	311 971 939	☆ Cable clip ..... from Chassis No. 117 000 001	1	M 22, M 23, M 47, M 102, M 616
-	311 971 939 A	Cable clip .....	x	

Key No.	Part No.	Description	Quantity	Type and model
-	111 971 940	Butt connector red - Cable 0.5 - 1.0 .....	x	
33	111 971 941	Flat terminal 6.3x2.5 - Cable B 0.5-2.5 .....	x	
-	111 971 943	Flat terminal 6.3x6 - Cable B 3-6 .....	x	
-	111 971 945 A	Flat terminal 9.5x10 with cable - Connection .... to voltage regulator from Chassis No. 115 000 001 up to 118 850 239	1	
-	111 971 945 B	Cable shoe A 5x4 with cable for regulator .....	1	and generator from Chassis No. 118 850 240
-	111 971 947	Cable shoe 5 - Cable 4.0 - 6.0 .....	x	
-	111 971 948	Cable shoe 8 - Cable 4.0 - 6.0 .....	x	
-	111 971 949	Cable shoe 5 - Cable 1.0 - 2.5 .....	x	from Chassis No. 118 850 240
-	111 971 950	Cable shoe 8 - Cable 1.0 - 2.5 .....	x	
-	111 971 951	Angle terminal sleeve EF 7.7x2.5 with cable - .. Headlamp connection from Chassis No. 115 000 001	x	
-	111 971 957	Flat connector with retaining lug .....	x	for 2.8x0.5 mm tab - Cable 0.5 - 1.0
-	111 971 958	Flat connector with retaining lug .....	x	for 2.8x0.8 mm tab - Cable 0.5 - 1.5
-	111 971 959	Flat connector with retaining lug .....	x	for 6.3x0.8 mm tab - Cable 0.5 - 1.0
-	111 971 960	Flat connector with retaining lug .....	x	for 6.3x0.8 mm tab - Cable 1.5 - 2.5
-	111 971 961	Flat connector with retaining lug .....	x	for 6.3x0.8 mm tab - Cable 4.0 - 6.0
-	111 971 965	Angled connector - tab, 6.3x0.8 mm - .....	x	Cable 1.0 - 2.5

Key No.	Part No.	Description	Quantity	Type and model
-	111 971 966	Angled connector with retaining lug ..... for 8.0-0.8 mm tab - Cable 1.5-2.5	x	
-	111 971 977	Flat terminal insulator, single ..... from Chassis No. 118 758 160	x	
-	111 971 983	Tab 2.8-0.8 mm with retaining lug - ..... Cable 0.5-1.5	x	
-	111 971 984	Tab 2.8-1.0 mm with retaining lug - ..... Cable 0.5-1.0	x	
-	111 971 985	Tab 6.3x0.8 mm with retaining lug - ..... Cable 0.5-1.0	x	
-	111 971 986	Tab 6.3x0.8 mm with retaining lug - ..... Cable 1.5-2.5	x	
-	111 971 987	Tab 6.3x0.8 mm with retaining lug - ..... Cable 4.0-6.0	x	
-	N 18 004 1	Protective tubing 4 mm dia. ....	*	
-	N 18 006 1	Protective tubing 6 mm dia. ....	*	
-	N 18 009 1	Protective tubing 9 mm dia. ....	*	
-	N 18 014 1	Protective tubing 14 mm dia. ....	*	
-	N 18 203 3	Cable B 0.5 .....	*	
-	N 18 227 7	Cable B 1.0 .....	*	
-	N 18 231 1	Cable B 1.5 .....	*	
-	N 18 248 8	Cable B 2.5 .....	*	
-	N 18 263 3	Cable B 6 .....	*	

Key No.	Part No.	Description	Quantity	Type and model
-	111 971 986	Tab 6.3×0.8 mm with retaining lug - ..... Cable 1.5 - 2.5	X	
-	111 971 987	Tab 6.3×0.8 mm with retaining lug - ..... Cable 4.0 - 6.0	X	
-	N 18 004 1	Protective tubing 4 mm dia. ....	*	
-	N 18 006 1	Protective tubing 6 mm dia. ....	*	
-	N 18 009 1	Protective tubing 9 mm dia. ....	*	
-	N 18 014 1	Protective tubing 14 mm dia. ....	*	
-	N 18 203 3	Cable B 0.5 .....	*	
-	N 18 227 7	Cable B 1.0 .....	*	
-	N 18 231 1	Cable B 1.5 .....	*	
-	N 18 248 8	Cable B 2.5 .....	*	
-	N 18 263 3	Cable B 6 .....	*	

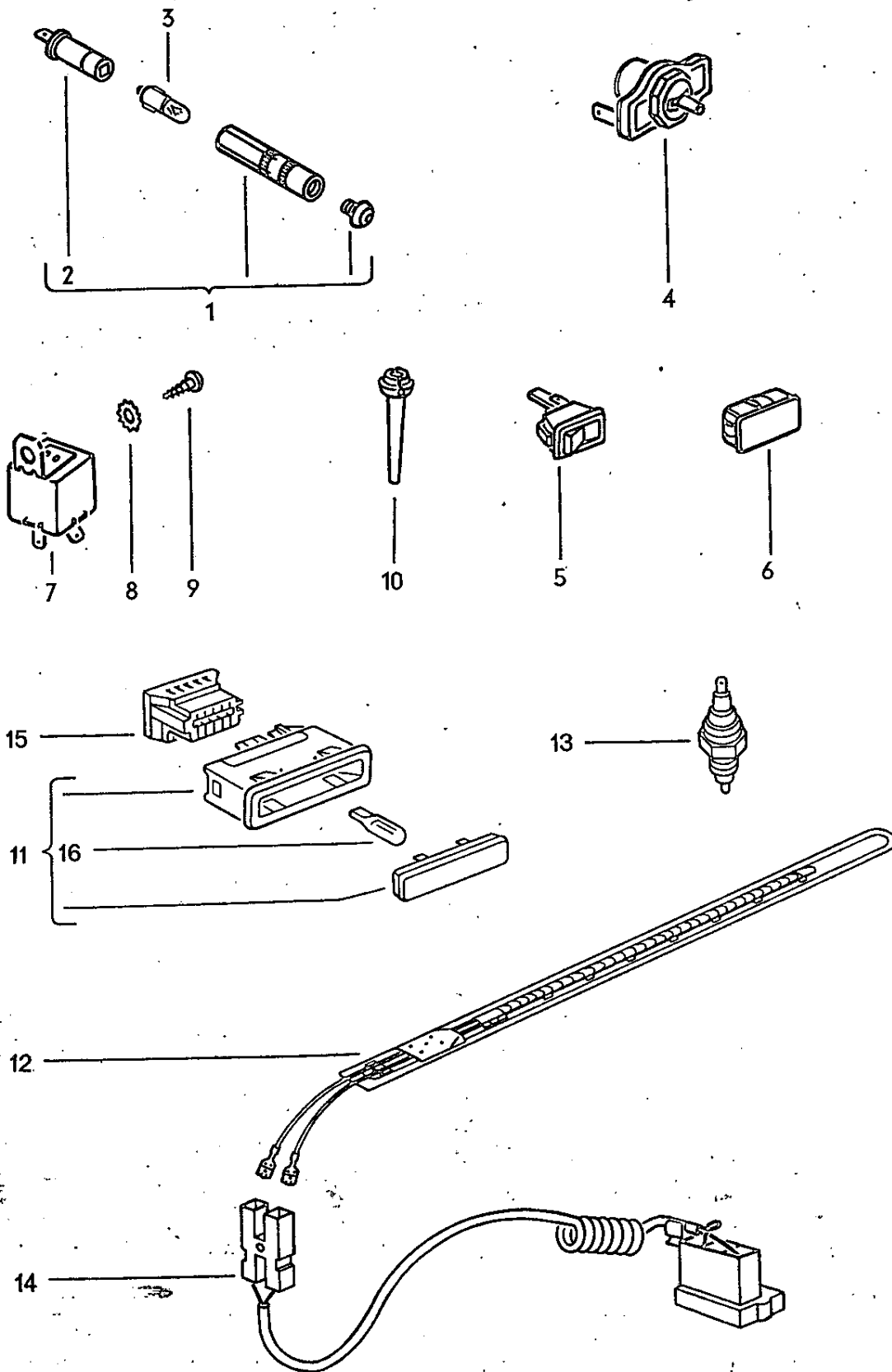

Key No.	Part No.	Description	Quantity	Type and model
<b>INSTALLATION PARTS FOR REAR WINDOW (HEATABLE)</b>				M 102
1	*113 919 237	Warning lamp (red) – Rear window glass, heatable up to Chassis No. 117 999 000	1	
2	111 957 397	Socket – Bulb .....	1	
3	N 17 722 2	Bulb J 12 V 2 W .....	1	
(3)	N 17 722 1	Bulb J 6 V 1.2 W .....	1	
4	*211 947 511 D	Tumbler switch – Rear window glass, heatable ... up to Chassis No. 110 3100 000	1	
5	113 959 621 B SS 134 311-959-621A	Tumbler switch – Rear window glass, heatable ... from Chassis No. 111 2000 001	1	
6	113 959 623	Plug – Switch opening .....	1	
		(heatable rear window) from Chassis No. 111 2000 001	1	
7	*111 963 141 B SS 134 311 906061C	Relay 12 V – Rear window glass (heatable) .....	1	
(7)	*311 963 139	Relay 6 V – Rear window glass (heatable) .....	1	
8	N 12 104 2	Spring washer A 5.3 .....	1	
		from Chassis No. 110 2000 001	1	
9	N 13 968 1	Tapping screw, fillister head B 4.8X9.5 .....	1	
		from Chassis No. 110 2000 001	1	
10	143 971 919	Grommet – Rear window glass, heatable .....	1	

Key No.	Part No.	Description	Quantity	Type and model
<b>INSTALLATION PARTS FOR SAFETY BELT WARNING SYSTEM</b>				
from Chassis No. January 1972			M 185: 113, 117, 151	
11	113 919 234	Warning light – Safety belt warning system .....	1	
12	113 919 385	Contact strip – Safety belt warning system .....	1	
13	113 941 551	Switch – Safety belt warning system .....	1	
-	N 13 814 2	Seal A 14×18×1.5 .....		
14	411 971 800	Cable – Safety belt warning system .....	1	
15	113 971 974	Terminal pin housing – Warning light .....	1	
16	N 17 751 2	Bulb JG 12 V 1.2 W .....	1	

Part No.	Description	Quantity
25 DIN b.h.p.=30 SAE , 30=36 , 34=41.5 , 37=47 , 40=49/50 , 44=52/53 , 46=55 , 47=57 , 48=58 , 50=60		

**REPAIR KITS**

<b>111 998 021</b>	<b>Steering-ignition lock silver beige for service installation</b> (for RHD from Chassis No. 1 600 440 only) comprising:	
113 415 431 A	Nut, hex. M 8 (self locking) .....	1
111 415 521 D	Locking shell .....	2
111 415 603 B	Rubber bush .....	1
111 415 609	Protective ring - Rubber bush .....	1
111 905 851 H	Steering-ignition lock .....	1
	466 silver beige	
111 905 877	Washer .....	2
111 905 881	Bolt 36 mm .....	1
111 905 881 A	Bolt 67 mm .....	1
<b>111 998 031 A</b>	<b>1 set of ignition cables, suppressed</b> from Engine No. 1 - 695 282 (30-, 34 b.h.p.) up to Engine No. E 0 022 000 (37 b.h.p.) up to Engine No. F 2 200 000 (40 b.h.p.) up to Engine No. L 0 026 500 (40 b.h.p.) up to Engine No. H 1 350 000 (44 b.h.p.) up to Engine No. B 6 600 000 (47 b.h.p.) from Engine No. AB, AC, AD, AE, AF, AH 0 000 001 (40-, 44-, 46-, 48-, 50 b.h.p.) comprising:	
	Ignition cable for cylinder 1 and 2 .....	2
	Ignition cable for cylinder 3 and 4 .....	2
	Ignition cable from coil to distributor .....	1
<b>111 998 031 B</b>	<b>1 set of suppressed ignition cables (M 123)</b> from Engine No. D 0 675 000 (34 b.h.p.) from Engine No. AB, AC, AD, AE, AF, AH 0 000 001 (40-, 44-, 46-, 48-, 50 b.h.p.) comprising:	
	Ignition cable for cylinder 1 and 2 .....	2
	Ignition cable for cylinder 3 and 4 .....	2
	Ignition cable from coil to distributor .....	1
<b>111 998 033 A</b>	<b>1 set of ignition cables, suppressed (M 123)</b> up to Engine No. D 0 674 999 (34 b.h.p.) up to Engine No. E 0 022 000 (37 b.h.p.) up to Engine No. F 2 200 000 (40 b.h.p.) up to Engine No. L 0 026 500 (40 b.h.p.) up to Engine No. H 1 350 000 (44 b.h.p.) up to Engine No. B 6 600 000 (47 b.h.p.) comprising:	
	Ignition cable for cylinder 1 .....	1
	Ignition cable for cylinder 2 .....	1
	Ignition cable for cylinder 3 and 4 .....	2
	Ignition cable from coil to distributor .....	1



Part No.	Description	Quantity
25 DIN b.h.p.=30 SAE , 30=36 , 34=41.5 , 37=47 , 40=49/50 , 44=52/53 , 46=55 , 47=57 , 48=58 , 50=60		
<b>113 998 035</b>	<b>1 set of sealing parts for ignition system and generator</b> from Chassis No. 158 000 001 up to 159 1200 000: 151, 152 from Chassis No. 110 2000 001 up to 110 3100 000: 113, 114, 117, 118 from Chassis No. 111 2000 001 up to 111 3200 000: M 87	
	comprising:	
181 903 197	Cover band .....	1
113 903 365	Insulating washer, 13 mm dia. ....	2
113 903 367	Insulating washer, 15.5 mm dia. ....	2
311 905 429 A	Cap .....	6
311 905 444 A	Cap .....	4
113 971 901	Cap .....	1
113 971 901 A	Cap .....	1
<b>111 998 051</b>	<b>1 set of breaker points for distributor</b> up to Engine No. 1 - 695 281	
	comprising:	
	Breaker point .....	1
	Arm - Contact breaker .....	1
<b>111 998 053</b>	<b>1 set of breaker points for distributor</b> from Engine No. 1 - 695 282 up to 3 912 903	
	comprising:	
	Breaker point .....	1
	Arm - Contact breaker .....	1
<b>111 998 055</b>	<b>1 set of breaker points for distributor 141 905 205</b>	
	comprising:	
	Breaker point .....	1
	Arm - Contact breaker .....	1
<b>111 998 057</b>	<b>1 set of breaker points for distributors 113 905 205 A/311 905 205</b>	
	comprising:	
	Breaker point .....	1
	Arm - Contact breaker .....	1
<b>111 998 059</b>	<b>1 set of breaker points for distributors ZV/JU 4 R 3, 111 905 205 M, 113 905 205 K</b>	
	comprising:	
	Breaker point .....	1
	Arm - Contact breaker .....	1

Part No.	Description	Quantity
<b>111 998 061</b>	<b>1 set of breaker points for distributors 113 905 205 B/J/L</b>	
	comprising:	
	Breaker point .....	1
	Arm – Contact breaker .....	1
<b>111 998 063</b>	<b>1 set of breaker points for distributor 113 905 205 M (M 157)</b>	
	comprising:	
	Breaker point .....	1
	Arm – Contact breaker .....	1
<b>311 998 063</b>	<b>1 set of breaker points for distributor 113 905 205 P/AA/AB</b>	
	comprising:	
	Breaker point .....	1
	Arm – Contact breaker .....	1
<b>111 998 101</b>	<b>Flashing Indicators for service installation</b>	
	comprising:	
113 953 041	Flashing indicator, front .....	2
111 953 185 B	Relay – Flashing indicator .....	1
111 953 193	Packing – Flashing indicator .....	2
111 953 547	Cable sleeve – Flashing indicator .....	1
111 971 941	Flat terminal .....	5
N 11 005 2	Nut, hex. M 5 .....	4
N 12 005 1	Lock washer B 5 .....	4
N 17 471 0	Connector .....	6
N 20 061 1	Grommet .....	1
<b>111 998 107 A</b>	<b>1 emergency light set 12 V for service installation</b>	
	comprising:	
211 953 215 C	Emergency light – Relay 12 V .....	1
211 953 235 A	Switch – Emergency light .....	1
111 953 245 B	Spindle with knob .....	1
111 941 515 D	Escutcheon – Emergency light switch .....	1
111 941 543 F	Lens, red without symbol, for emergency light switch .....	1
111 937 077	Cable connector .....	1



Part No.	Description	Quantity
111 971 385	Harness – Emergency light .....	1
111 971 511	Cable divider .....	3
111 971 941	Flat terminal .....	1
N 12 127 2	Shake-proof washer A 6.4 .....	1
N 13 971 1	Screw, countersunk raised head B 4.8×22 .....	1
N 17 751 2	Bulb G 12 V 1.2 W .....	1
111 998 111	<b>Headlamp flasher press button for service installation</b> from Chassis No. 2 528 668 up to 115 999 000 comprising:	
	Headlamp flasher press button .....	1
N 11 362 1	Tapping screw, cheese head BZ 2.2×6.5 .....	1
N 11 363 1	Tapping screw, cheese head BZ 2.2×11 .....	1
	Spring .....	1
	Terminal .....	1
111 971 941	Flat terminal .....	1
111 998 113	<b>Headlamp flasher press button with relay for service installation</b> from Chassis No. 2 528 668 up to 115 999 000 comprising:	
	Headlamp flasher press button .....	1
311 941 581 C	Relay – Headlamp flasher .....	1
N 11 362 1	Tapping screw, cheese head BZ 2.2×6.5 .....	1
N 11 363 1	Tapping screw, cheese head BZ 2.2×11 .....	1
	Spring .....	1
	Terminal .....	1
111 971 941	Flat terminal .....	1
111 998 131	<b>1 set of installation parts for rear window glass 6 V, heatable</b> (see Technical Bulletin E-19) comprising:	
113 919 237	Warning lamp .....	1
111 937 093 A	Connector .....	1
211 947 511 C	Tumbler switch .....	1

# MAIN GROUP



Part No.	Description	Quantity
311 963 139	Relay 6 V .....	1
111 971 511	Cable divider .....	2
311 971 939	Cable clip .....	4
111 971 941	Flat terminal .....	10
N 12 104 2	Spring washer A 5.3 .....	1
N 13 968 1	Tapping screw, fillister head B 4.8×13 .....	1
N 17 121 4	Fuse 16 A .....	1
N 17 722 1	Bulb J 6 V 1.2 W .....	1
<b>111 998 133</b>	<b>1 set of installation parts for rear window glass 12 V, heatable</b> <b>(see Technical Bulletin E-19)</b> comprising:	
113 919 237	Warning lamp .....	1
111 937 093 A	Connector .....	1
211 947 511 C	Tumbler switch .....	1
111 963 141 B	Relay 12 V .....	1
111 971 511	Cable divider .....	2
311 971 939	Cable clip .....	4
111 971 941	Flat terminal .....	10
N 12 104 2	Spring washer A 5.3 .....	1
N 13 968 1	Tapping screw, fillister head B 4.8×13 .....	1
N 17 722 2	Bulb J 12 V 2 W .....	1
<b>111 998 135</b>	<b>Back-up lamp for service installation</b> up to Chassis No. 117 999 000 from Chassis No. 118 000 001: 111, 112, 115, 116 comprising:	
113 707 191 B	Screw – Bumper .....	2
111 937 078	Cable divider .....	1
111 937 197	Clip .....	1
111 941 072	Back-up lamp .....	2
111 941 351	Retainer, left .....	1
111 941 352	Retainer, right .....	1
211 941 521	Switch – Back-up lamp .....	1
111 941 539	Boot .....	2
111 941 545	Nut, hex. ....	2
	Cable harness – Switch .....	1
	Cable harness – Back-up lamp left .....	1
	Cable – Back-up lamp right .....	1



Part No.	Description	Quantity
311 971 939	Cable clip .....	2
N 12 008 2	Lock washer B 8 .....	2
N 12 010 2	Lock washer B 10 .....	2
N 13 816 1	Gasket A 18X24 .....	1
<b>111 998 135 A</b>	<b>Back-up lamp for service installation</b> from Chassis No. 118 000 001: 113, 114, 117, 118, 151, 152 comprising:	
111 937 078	Cable divider .....	1
211 941 521	Switch – Back-up lamp .....	1
111 945 241 G	Lens – Brake/indicator light with back-up lamp .....	2
111 945 269	Bulb holder – Back-up lamp .....	2
	Harness – Switch .....	1
111 971 941	Flat terminal .....	4
N 17 710 2	Bulb 12 V 25 W .....	2
N 18 231 1	Cable W 1.5 .....	3 m
<b>111 998 151</b>	<b>Windshield wipers (aluminium painted) for service installation</b> up to Chassis No. 1 600 439 comprising:	
113 955 407 B	Bracket with windshield wiper arm, left .....	1
113 955 408 B	Bracket with windshield wiper arm, right .....	1
113 955 425 B	Blade – Windshield wiper .....	2
<b>111 998 161</b>	<b>Windshield wiper shaft, left with mounting parts</b> from Chassis No. 1 600 440 up to 6 502 399 comprising:	
111 955 215 B	Windshield wiper shaft .....	1
113 955 243 A	Nut, hex. ....	2
111 955 245	Washer .....	1
111 955 255 A	Washer .....	2
111 955 261 A	Ferrule – Windshield wiper bearing .....	2
111 955 265 A	Ferrule – Windshield wiper bearing .....	1
113 955 275 B	Bearing cover .....	1
111 955 346 A	Lock washer .....	1
111 955 349	Spring washer .....	1
N 12 231 1	Spring washer B 10 .....	1

**MAIN GROUP**



Part No.	Description	Quantity
<b>111 998 161 A</b>	<b>Windshield wiper shaft, left with mounting parts</b> from Chassis No. 115 000 001 up to 117 999 000: 111-118, 151, 152 from Chassis No. 118 000 001 up to 119 1200 000: 111, 112, 115, 116 comprising:	
111 955 216 C	Windshield wiper shaft .....	1
113 955 243 A	Nut, hex. ....	2
111 955 245	Washer .....	1
111 955 255 A	Washer .....	1
111 955 261 B	Ferrule - Windshield wiper bearing .....	1
113 955 275 B	Bearing cover .....	1
111 955 346 A	Lock washer .....	2
111 955 349	Spring washer .....	2
N 12 231 1	Spring washer B 10 .....	1
<b>111 998 161 B</b>	<b>Windshield wiper shaft, left with mounting parts</b> from Chassis No. 118 000 001 up to 119 1200 000: 113, 114, 117, 118, 151, 152 comprising:	
111 805 167 A	Spring washer .....	2
111 955 216 D	Windshield wiper shaft .....	1
113 955 243 A	Nut, hex. ....	2
111 955 245	Washer .....	1
111 955 255 A	Washer .....	1
111 955 261 B	Ferrule - Windshield wiper bearing .....	1
113 955 275 B	Bearing cover .....	1
N 12 231 1	Spring washer B 10 .....	1
N 12 436 2	Lock washer .....	2
<b>111 998 161 C</b>	<b>Windshield wiper shaft, left with mounting parts</b> from Chassis No. 110 2000 001: 113, 114, 117, 118, 151, 152 comprising:	
111 805 167 A	Spring washer .....	2
111 955 216 E	Windshield wiper shaft .....	1
311 955 255	Washer .....	1
311 955 243 A	Nut, hex. ....	2
311 955 261 A	Ferrule - Windshield wiper bearing .....	1
211 955 275 A	Bearing cover .....	1
211 955 417 A	Cap nut .....	1
N 12 227 3	Spring washer .....	1
N 12 232 1	Spring washer .....	1
N 12 436 2	Lock washer .....	2



Part No.	Description	Quantity
<b>111 998 161 D</b>	<b>Windshield wiper shaft, left with mounting parts</b> from Chassis No. 110 2000 001: 111, 112, 114, 116 comprising:	
111 955 215 H	Windshield wiper shaft .....	1
311 955 243 A	Nut, hex. ....	2
311 955 255	Washer .....	2
311 955 261 A	Ferrule - Windshield wiper bearing .....	1
211 955 275 A	Bearing cover .....	1
111 955 346 A	Lock washer .....	2
111 955 349	Spring washer .....	2
N 12 232 1	Spring washer .....	1
<b>111 998 161 E</b>	<b>Windshield wiper shaft, left with mounting parts</b> from Chassis No. 118 000 001 up to 119 1200 000: 113, 114, 117, 118, 151, 152 (for installation in bodies with 15 mm dia. opening only) comprising:	
111 955 215 J	Windshield wiper shaft .....	1
311 955 243 A	Nut, hex. ....	2
311 955 255	Washer .....	2
311 955 261 A	Ferrule - Windshield wiper bearing .....	1
211 955 275 A	Bearing cover .....	1
111 805 167 A	Spring washer .....	2
N 12 232 1	Spring washer .....	2
N 12 436 2	Lock washer .....	2
<b>111 998 162</b>	<b>Windshield wiper shaft, right with mounting parts</b> from Chassis No. 1 600 440 up to 6 502 399 comprising:	
111 955 216 B	Windshield wiper shaft .....	1
113 955 243 A	Nut, hex. ....	2
111 955 245	Washer .....	1
111 955 255 A	Washer .....	2
111 955 261 A	Ferrule - Windshield wiper bearing .....	2
111 955 265 A	Ferrule - Windshield wiper bearing .....	1
113 955 275 B	Bearing cover .....	1
111 955 346 A	Lock washer .....	2
111 955 349	Spring washer .....	2
N 12 231 1	Spring washer B 10 .....	1

Part No.	Description	Quantity
<b>111 998 162 A</b>	<b>Windshield wiper shaft, right with mounting parts</b> from Chassis No. 115 000 001 up to 117 999 000: 111-118, 151, 152 from Chassis No. 118 000 001 up to 119 1200 000: 111, 112, 115, 116 comprising:	
111 955 215 B	Windshield wiper shaft .....	1
113 955 243 A	Nut, hex. ....	2
111 955 245	Washer .....	1
111 955 255 A	Washer .....	1
111 955 261 B	Ferrule – Windshield wiper bearing .....	1
113 955 275 B	Bearing cover .....	1
111 955 346 A	Lock washer .....	1
111 955 349	Spring washer .....	1
N 12 231 1	Spring washer B 10 .....	1
<b>111 998 162 B</b>	<b>Windshield wiper shaft, right with mounting parts</b> from Chassis No. 118 000 001 up to 119 1200 000: 113, 114, 117, 118, 151, 152 comprising:	
111 805 167 A	Spring washer .....	1
111 955 215 C	Windshield wiper shaft .....	1
113 955 243 A	Nut, hex. ....	2
111 955 245	Washer .....	1
111 955 255 A	Washer .....	1
111 955 261 B	Ferrule – Windshield wiper bearing .....	1
113 955 275 B	Bearing cover .....	1
N 12 231 1	Spring washer B 10 .....	1
N 12 436 2	Lock washer .....	1
<b>111 998 162 C</b>	<b>Windshield wiper shaft, right with mounting parts</b> from Chassis No. 110 2000 001: 113, 114, 117, 118, 151, 152 comprising:	
111 805 167 A	Spring washer .....	2
111 955 215 D	Windshield wiper shaft .....	1
311 955 255	Washer .....	1
311 955 243 A	Nut, hex. ....	2
311 955 261 A	Ferrule – Windshield wiper bearing .....	1
211 955 275 A	Bearing cover .....	1
211 955 417 A	Cap nut .....	1
N 12 227 3	Spring washer .....	1
N 12 232 1	Spring washer .....	1
N 12 436 2	Lock washer .....	2



Part No. Description Quantity

**111 998 162 D** Windshield wiper shaft, right with mounting parts  
from Chassis No. 110 2000 001: 111, 112, 115, 116  
comprising:

- 111 955 216 H	Windshield wiper shaft .....	1
- 311 955 243 A	Nut, hex. ....	2
- 311 955 261 A	Ferrule - Windshield wiper bearing .....	1
- 211 955 275 A	Bearing cover .....	1
- 311 955 255	Washer .....	2
- 111 955 346 A	Spring washer .....	2
- 111 955 349	Spring washer .....	2
- N 12 232 1	Lock washer .....	1

**111 998 162 E** Windshield wiper shaft, right with mounting parts  
from Chassis No. 118 000 001 up to 119 1200 000: 113, 114, 117, 118, 151, 152  
(for installation in bodies with 15 mm dia. opening only)

comprising:

111 955 216 J	Windshield wiper shaft .....	1
311 955 243 A	Nut, hex. ....	2
311 955 255	Washer .....	2
311 955 261 A	Ferrule - Windshield wiper bearing .....	1
211 955 275 A	Bearing cover .....	1
111 805 167 A	Spring washer .....	2
N 12 232 1	Spring washer .....	2
N 12 436 2	Lock washer .....	2